

OD series servo driver user manual



Preface Product Acceptance

Thank you for using Kinco Servo product !

Item for Acceptance	Remark
Whether the model of a delivered FD series servo system is consistent with the specified model	Check the nameplate of a servo motor and that of a servo driver
Whether the motor wiring is correct	Purchase motor accessory packages if no wiring are purchased
Whether the accessories included in the packing list are complete	Check the packing list
Whether any breakage occurs	Check the external appearance completely for any losses that are caused by transportation

If there is any problem with any of the above, please contact our company or your supplier to solve it.

Parts list

Accessory package	Name	Model	Count	Note
X1, X2 interface accessories	IO plug	MOLEX 5016462000	1	
	Encoder plug	MOLEX 5016461600	1	
	Metal pin	MOLEX 5016471000	38	IO plug and encoder plug share the same metal pin
X3A(in)/X3B(OUT) interface accessories (CANor RS485)	Communication plug	MOLEX 513820500	2	
	Metal pin	MOLEX 561349000	12	
X4 interface accessories (RS232)	Communication plug	CJT A2008H-04P	1	
	Metal pin	CJT A2008-TP	5	
Other accessories	Qualification certificate_bilingual edition	-	1	
	Service directory	-	1	

Manual version change record

Version Date	Version description
In May 2020	The new product manual was released
In Aug 2020	Table 3-6 Description of pin names of magnetolectric encoders
In Feb 2024	Add the description of encoder Cables and Power cables in Section 3.3
In May 2024	Section 1.2 1. The maximum continuous output current parameter adds the current that can be achieved without auxiliary heat dissipation 2. Modify the cooling mode description
In June 2024	1.2 Correct pulse direction control parameter voltage range 1.4 Update the latest motor configurations 2.3 , 2.4 Update the latest motor size diagram and speed - torque characteristic diagram 3.2, 3.3.5 Modify the power supply voltage range 3.3.1 Delete the incorrect description of the pulse input terminal 4.6 Modify the table number
In October 2024	3.3.4 Correct the RS232 interface pin number Add OD114S drive technical parameter

Catalog

Preface Product Acceptance	1
Parts list	1
Manual version change record	2
Catalog	3
Chapter 1 System configuration and types	5
1.1 Equipment features	5
1.2 Product Specifications	5
1.3 Description of products	6
1.3.1 Naming rule	6
1.3.2 Nameplate instructions	8
1.4 Configuration table of servo system	8
1.5 Brake resistance selection table	9
Chapter 2 System installation requirements and precautions	10
2.1 Application requirements of driver	10
2.1.1 Transportation and saving conditions	10
2.1.2 Technology requirements	10
2.1.3 Operator' s requirements	10
2.1.4 Environment requirements	11
2.1.5 Precautions for the use of servo driver	11
2.1.6 Matters needing attention for use of servo motor	11
2.2 Driver installation size diagram	13
2.3 External dimensions of servo motor	14
2.3.1 40 External dimensions of flange motor	14
2.3.2 60 External dimensions of flange motor	15
2.3.3 80 External dimensions of flange motor	16
2.4 Servo motor torque curve	17
2.4.1 50W servo motor torque curve	17
2.4.2 100W servo motor torque curve	17
2.4.3 200W servo motor torque curve	18
2.4.4 400W servo motor torque curve	18
2.4.5 600W servo motor torque curve	18

2.4.6 750W servo motor torque curve	19
2.4.7 1000W servo motor torque curve	19
Chapter 3 System Interface and Wiring	20
3.1 Name of OD servo parts	20
3.2 External wiring mode	20
3.3 Interface and cable instruction	22
3.3.1 External input output interface (X1)	22
3.3.2 Encoder interface (X2)	24
3.3.3 Bus communication interface (X3)	26
3.3.4 232 Communication serial port (X4)	29
3.3.5 Power interface (X5)	29
3.3.6 Driver indicator	31
Chapter 4 Working mode introduction	32
4.1 Trial operation	32
Step 1: Hardware wiring	32
Step 2: Drive I/O software configuration	32
Step 3: Set relevant parameters	32
4.2 Velocity mode (-3, 3)	33
4.2.1 Analog speed mode	34
4.2.2 DIN Speed mode	36
4.3 Torque mode (4)	37
4.3.1 Analog torque mode	38
4.4 Position mode (1)	40
4.4. 1 DIN position mode	40
4.5 Pulse mode (-4)	42
4.6 Homing mode (6)	43
Capter 5 Performance Adjustment	50
5.1 Tuning of velocity loop	51
5.2 Tuning of position loop	53
5.3 Factors which influence tuning results	55
Chapter 6 Alarms and troubleshooting	56
Appendix 1 Control terminal wire making instructions	60

Chapter 1 System configuration and types

1.1 Equipment features

For customers with limited installation space, Kinco has introduced the ultra-small volume OD series driver. The modular design scheme can be quickly combined into an integrated control scheme, and customized development can be carried out according to different working conditions of users:

- New miniaturized terminal design, more compact structure, more beautiful appearance;
- Can drive 50W~750W low voltage servo motor;
- Support photoelectric, magnetic encoder and other motors;
- Support dual power supply, improve system stability, easy to debug on site;
- It supports CANopen, Ethercat and other communication protocols, and can be seamlessly connected with mainstream controllers such as Omron and Beckhoff on the market;
- Provides a variety of AGV industry specific features: alarm braking, enhanced battery life;

1.2 Product Specifications

Model parameters	OD114S-□A-000	OD124S-□A-000	OD134S-□A-000
Power	24VDC ~ 60VDC		
Logic power	24VDC 1A (unnecessary)		
Rated output current	2.5A	10A (up to 9A without auxiliary cooling)	20A (up to 13A without auxiliary cooling)
Peak output current	12Ap	36Ap	80Ap
Feedback signal	2500P/R incremental differential 5V encoder Communication magnetoelectric encoder		
Resistance braking	External brake resistor can be connected		
Energy consumption brake voltage absorption point	Default 73V, can be set by software, object name chopper voltage point, address 0x651008		
Overvoltage alarm voltage	Default 83V, can be set by software, object name overvoltage alarm point, address 0x651009		
Undervoltage alarm voltage	Default 18V, can be set by software, object name low voltage alarm point, address 0x651007		
Cooling Type	Air cooling	Air cooling Note: Add size of 150mm*150mm*10mm oxide black 6063 aluminum plate radiator	
Weight (KG)	0.266		0.393
Input	4 digital input COMI terminal, high level: 12.5 ~ 30VDC, low level: 0 ~ 5VDC, maximum frequency: 1kHz, input impedance: 5K Ω		
Output specifications	2 channels of digital output OUT1 and OUT2, the driving current is 100mA at most, 1 channel of the switch to drive the output OUT5 needs an external 24VDC, the driving current is 500mA at most		

Pulse direction control	Pulse + direction, CCW+CW, A +B phase (3.3V ~ 24V)
RS232	The maximum support 115.2K baud rate, can use Kinco upper computer software link, can also use a custom protocol to communicate with the controller
RS485	The maximum support 115.2K baud rate, can use the Modbus RTU protocol to communicate with the controller
CAN BUS	Maximum support 1M baud rate, can use CANopen protocol to communicate with the controller
EtherCAT	Support COE (CIA402 protocol) and CSP/CSV/PP/PV/PT/HM mode, communication speed 100M
Protection function	Overvoltage protection, undervoltage protection, motor overheating (I ² T) protection, short circuit protection, driver overheating protection, etc
<p>Note: □=L: Communication Interface RS232、RS485 □=C: Communication Interface RS232、CANopen □=E: Communication Interface RS232、EtherCAT</p>	

1.3 Description of products

1.3.1 Naming rule

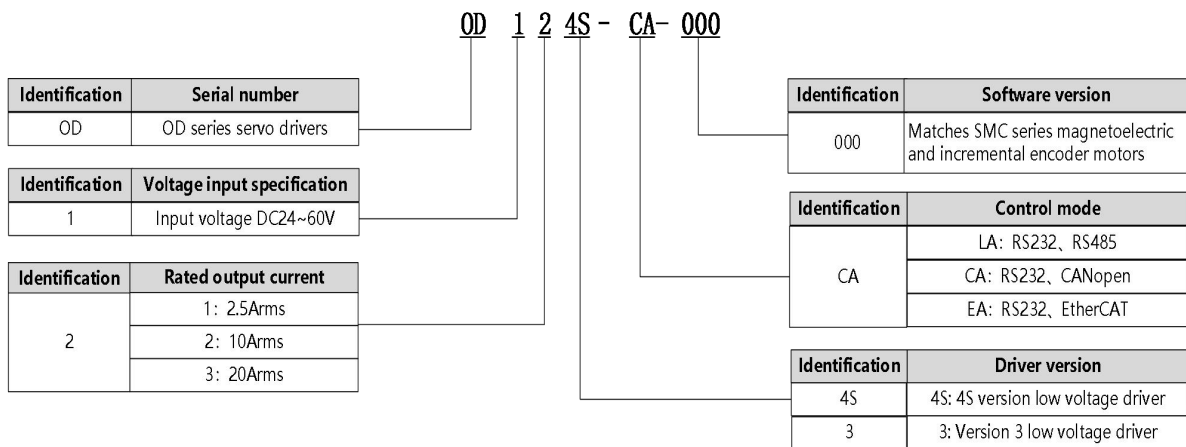


Figure1-1 Drive naming rules

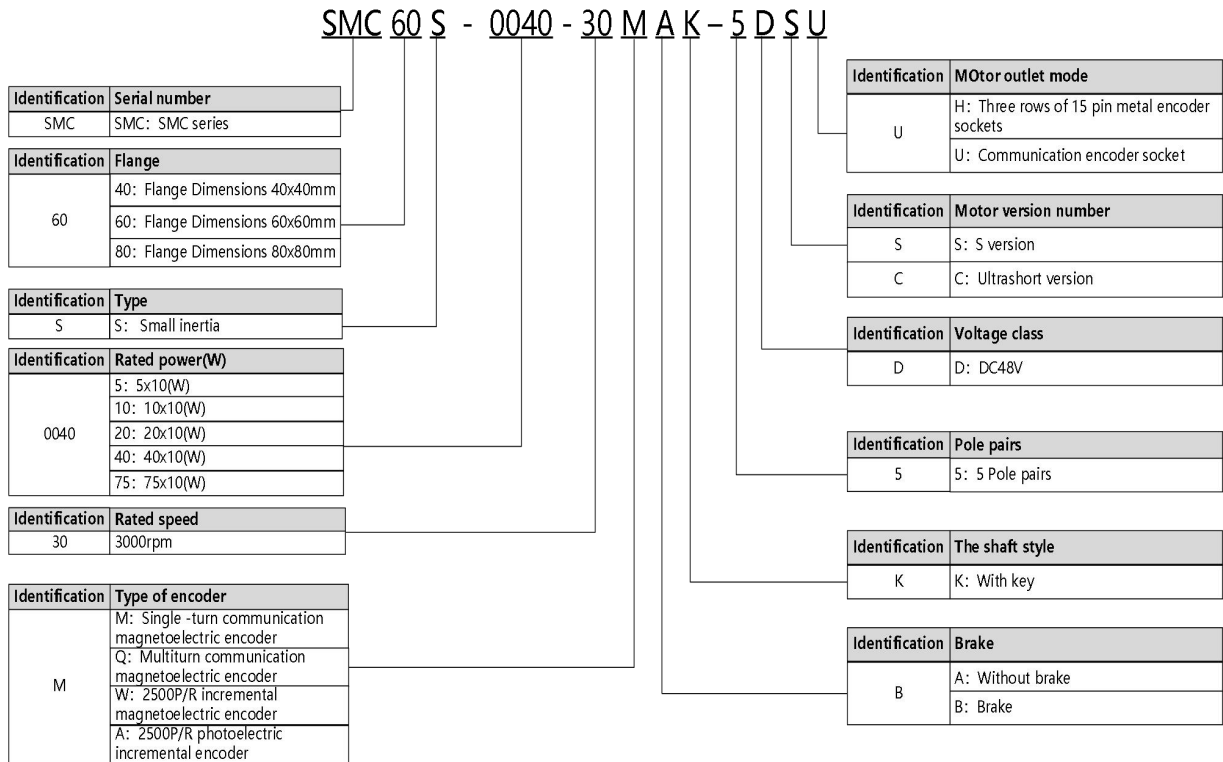


Figure1-2 Naming Rules of Motor

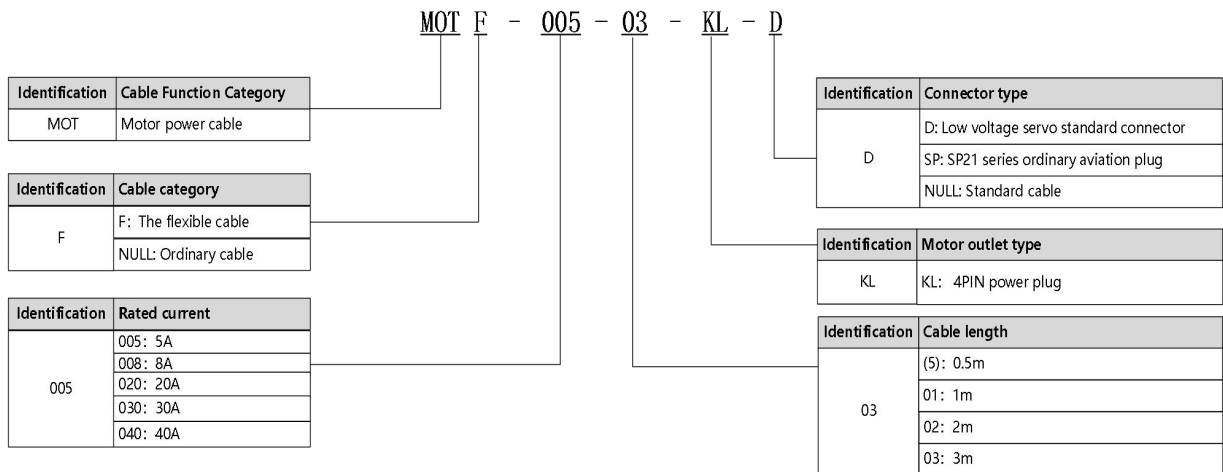


Figure1-3 Naming rules for power cable

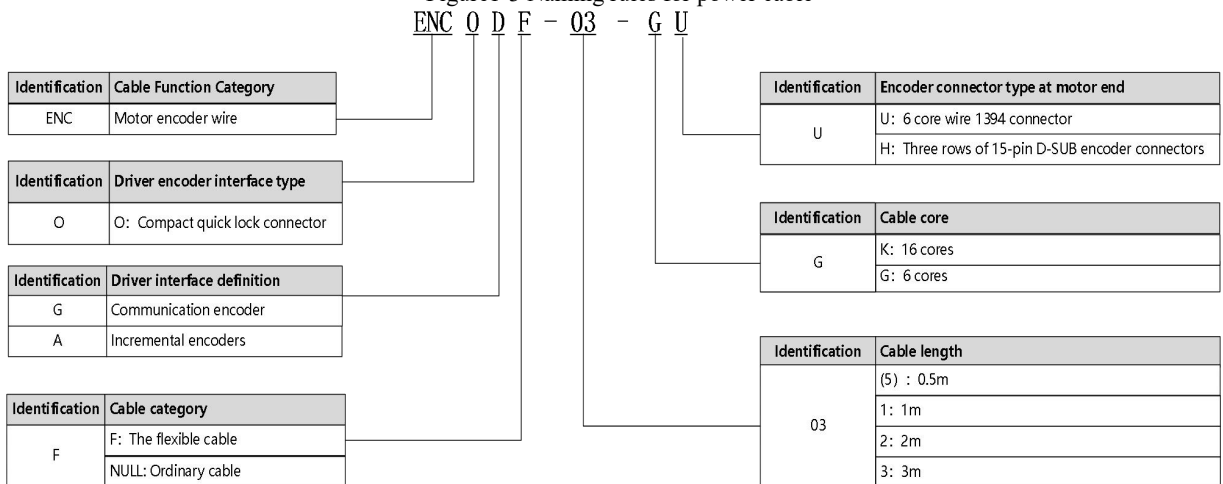


Figure1-4 Encoder line naming rules

1.3.2 Nameplate instructions

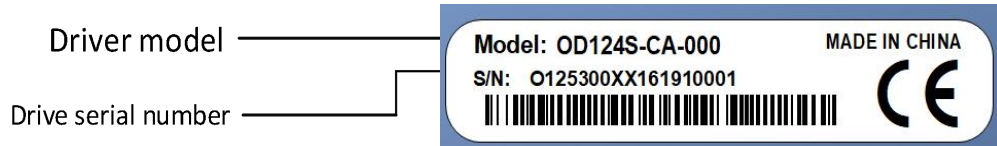


Figure 1-5 Description of the driver nameplate

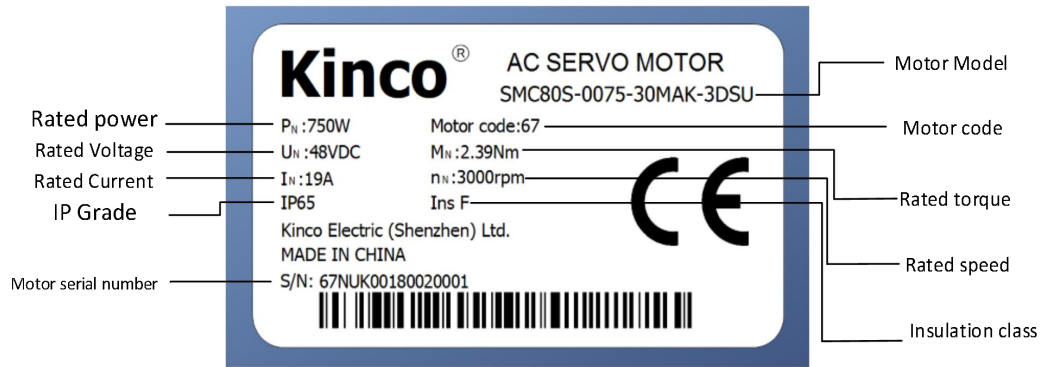


Fig. 1-6 Motor nameplate description

1.4 Configuration table of servo system

Description	Rated power Rated speed Rated torque	Servo motor	Power line/Brake line	Encoder line	Servo driver
16-bit single-loop magnetoelectric encoder motor	50W 3000rpm 0.16Nm	SMC40S-0005-30MAK-5DSU	MOT-005-LL-KL-D	ENCOG-LL-GU	OD114S-CA-000 OD114S-EA-000 OD114S-LA-000
		SMC40S-0005-30MBK-5DSU	MOT-005-LL-KL-D BRA-LL-KL		
	100W 3000rpm 0.32Nm	SMC40S-0010-30MAK-5DSU	MOT-005-LL-KL-D		
		SMC40S-0010-30MBK-5DSU	MOT-005-LL-KL-D BRA-LL-KL		
	200W 3000rpm 0.64Nm	SMC60S-0020-30MAK-5DSU	MOT-005-LL-KL-D		
		SMC60S-0020-30MBK-5DSU	MOT-005-LL-KL-D BRA-LL-KL		
	400W 3000rpm 1.27Nm	SMC60S-0040-30MAK-5DSU	MOT-008-LL-KL-D		
		SMC60S-0040-30MBK-5DSU	MOT-008-LL-KL-D BRA-LL-KL		
	600W 3000rpm 1.91Nm	SMC60S-0060-30MAK-5DSU	MOT-020-LL-KL-SP-1		
		SMC60S-0060-30MBK-5DSU	MOT-020-LL-KL-SP-1 BRA-LL-KL		
	750W 3000rpm 2.39Nm	SMC80S-0075-30MAK-5DSU	MOT-020-LL-KL-SP-1		
		SMC80S-0075-30MBK-5DSU	MOT-020-LL-KL-SP-1 BRA-LL-KL		
2500P/R Photoelectric encoder motor	200W 3000rpm 0.64Nm	SMC60S-0020-30AAK-5DSH	MOT-005-LL-KL-D	ENCOA-LL-KH	OD124S-CA-000 OD124S-EA-000 OD124S-LA-000
		SMC60S-0020-30ABK-5DSH	MOT-005-LL-KL-D BRA-LL-KL		

	400W 3000rpm 1.27Nm	SMC60S-0040-30AAK-5DSH	MOT-008-LL-KL-D	ENCOA-LL-KH	OD134S-CA-000 OD134S-EA-000 OD134S-LA-000
		SMC60S-0040-30ABK-5DSH	MOT-008-LL-KL-D BRA-LL-KL		
	600W 3000rpm 1.91Nm	SMC60S-0060-30AAK-5DSH	MOT-020-LL-KL-SP-1		
		SMC60S-0060-30ABK-5DSH	MOT-020-LL-KL-SP-1 BRA-LL-KL		
	750W 3000rpm 2.39Nm	SMC80S-0075-30AAK-5DSH	MOT-020-LL-KL-SP-1		
		SMC80S-0075-30ABK-5DSH	MOT-020-LL-KL-SP-1 BRA-LL-KL		
2500P/R incremental Magnetoelectric encoder motor	200W 3000rpm 0.64Nm	SMC60S-0020-30WAK-5DCH	MOT-005-LL-KL-D	ENCOA-LL-KH	OD124S-CA-000 OD124S-EA-000 OD124S-LA-000
		SMC60S-0020-30WBK-5DCH	MOT-005-LL-KL-D BRA-LL-KL		
	400W 3000rpm 1.27Nm	SMC60S-0040-30WAK-5DCH	MOT-008-LL-KL-D		
		SMC60S-0040-30WBK-5DCH	MOT-008-LL-KL-D BRA-LL-KL		
	750W 3000rpm 2.39Nm	SMC80S-0075-30WAK-5DCH	MOT-020-LL-KL-SP-1		
		SMC80S-0075-30WBK-5DCH	MOT-020-LL-KL-SP-1 BRA-LL-KL		

Note: LL is the cable length, and you can choose 0.5 m, 1 m, 2 m and 3 m cable

1.5 Brake resistance selection table

Driver model	Brake resistance value [Ω]	Brake resistance power [W]	Brake resistance withstand voltage[VDC] (Minimum)
OD114S-LA/CA/EA-000	10	100	500
OD124S-LA/CA/EA-000	10	100	500
OD134S-LA/CA/EA-000	5	100	500

Chapter 2 System installation requirements and precautions

2.1 Application requirements of driver

- Please ensure this document can be provided for design engineer, operators and staffs (or machine) who is responsible to adjust and use this product
- Please ensure to follow requirements of this file all the time. And consider other accessory and module's file
- Please consider destination's law, and:
 - regulations and standards
 - test organization and insurance company's regulation
 - national specifications

2.1.1 Transportation and saving conditions

- Please ensure product do not overburn during the process of transportation and saving, including:
 - Mechanical load
 - non-allowed temperature
 - Water
 - Corrosive gas
- Please use original package to save and transport. Original package provide efficient protection so as to avoid influence of general issues

2.1.2 Technology requirements

- Specified connection and environment condition in product technology data and all of other connecting accessory's technology requirements. As long as product specification requirements are conformed, users are allowed to operate according to related safety regulations..
- Please follow instructions and alerts in this product

2.1.3 Operator' s requirements

- This product must be operated by electrical engineers who are familiar with instructions below:
 - Electrical control system's installation and operation
 - Regulations of operating safety project system
 - Regulations of accident protection and occupation safety
 - Product using menu

2.1.4 Environment requirements

Environment	Requirement
Working temperature	0 - 40°C (ice-free),When the working temperature exceeds 40°C, the driver needs to be derated
Working humidity	Less than 90%RH(no condensation)
Storage temperature	-10°C ~ 70°C (ice-free)
Storage humidity	90%RH (no condensation)
Atmospheric pressure	86kpa~106kpa
Altitude	Rated working altitude is below 1000 meters, when working altitude is above 1000 meters, every rise of 100 meters, need to drop 1.5% use, the maximum working altitude is 4000 meters above sea level
Installation site	Dust-free, dry, lockable (such as electric cabinet)
Installation Method	Vertical
Protection levels	IP20

2.1.5 Precautions for the use of servo driver

Item	Description
Check on electricity	When the input power voltage exceeds the tolerable range of the driver, it may cause damage to internal components and smoke. Please fully measure the input power voltage before connecting to the driver.Do not use faulty or damaged drives
Preinstall Environment	Please note that this product does not guarantee use beyond the product specification range
Security protection	Please equip the safety device to avoid the product failure to cause serious accidents or serious losses.
Alarm screen	When the drive alarms, please check the cause of the fault. Reset the alarm and continue to use after ensuring safe operation.
Hot-line work	Please do not remove the driver housing and cable connection end in the energized state in case of accidental electric shock.
Touch discreetly	In the process of use, the driver and brake resistor and other equipment may be in a high temperature state, do not directly touch the equipment with your hands.

2.1.6 Matters needing attention for use of servo motor

Item	Description
Stain proofing	Please wipe anti-rust agent on the motor's shaft and then make some anti-rust treatments.
Installation method	<p>Improper installation method will cause damage of motor's encoder. Please note the following during the installation process:</p> <ul style="list-style-type: none"> ● When operators installation pulleys on the servo motor shaft with key, it is necessary to use screw hole. In order to install pulleys, operators need to insert double-headed nail into screw holes and use washers on the surface of coupled end. Then use nuts to fix into pulleys gradually. ● For servo motor shaft with keys, Operator need to use screw hole on the shaft to install. For motors shaft with no key, operators need to use friction coupling or other analogous methods. ● When operators need to disassemble pulleys, operators need to use pulley remover so as to make shaft avoid strong impact of load. ● In order to make it more safe, it is necessary to install protection cover or some analogous equipment in rotation area. For example, pulleys installed on the shaft.

Centering	<ul style="list-style-type: none"> ● When it is connected with machine, please use coupling and make shaft center of servo motor and machine stay in a line. When operators install servo motors, please achieve requirements of centering accuracy. If centering is not accurate, there will be shock and sometimes it will make bearings and encoders.
Installation direction	<ul style="list-style-type: none"> ● Servo motors can be installed in vertical or horizontal direction.
Oil & water solution	<p>When it is used in the occasion with drops, please use after make sure protection level of servo. When oil will drop into shaft penetrating part (beside shaft penetrating part, please choose servo motors with oil seal. The using condition of servo motors with oil seal:</p> <ul style="list-style-type: none"> ● Make sure the oil level is lower than month of oil seal. ● Please use when oil seal make sure that oil splash degree is good. ● When servo motors are installed in vertical upward direction, please avoid oil accumulating in the month of oil seal.
Cable	Please do not make cable bending or pull the cable. When using it, please do not make it too tight.
Connector	<p>In terms of connectors, please note the following:</p> <ul style="list-style-type: none"> ● When connectors are connected. please make sure there is no foreign body such as trash or mental slices. ● When connectors are connected into servo motors, please connect to one side of servo motor's main circuit cable and make sure ground cable of main cable connecting stably. If operators first connect one side of encoder cable, then, encoder may have some faults because of voltage difference between PEs. ● During the process of wiring, please make sure pin arrangement is correct. ● Connector is made of resin. Please do not add pressure to avoid damage of connectors. ● When handling operations is done (cables are connected), please hold main body of servo motors. If operators just hold cable to handle, it may cause connectors damage or make cable cut off. ● If operators use bend cable, please do not add pressure to connectors during the process of wiring. If pressure is added to connectors, it will cause connector damage.



Warning

- Please install the servo system in strict accordance with the instructions of this manual. It can help you set up and operate the drive correctly and achieve optimal performance of the drive.

2.2 Driver installation size diagram

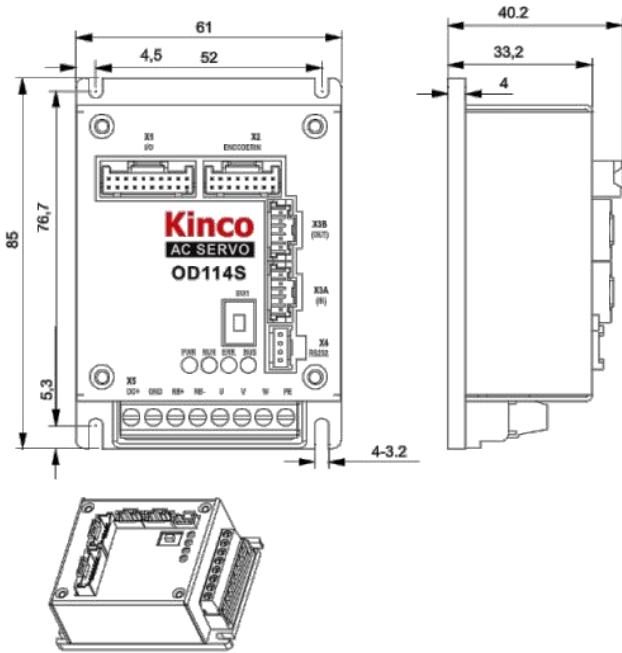


Figure 2-1 OD114S installation size diagram

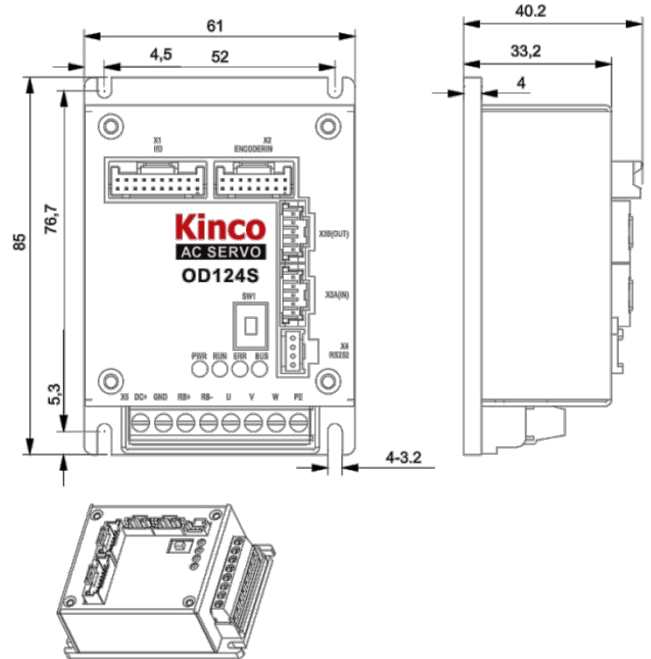


Figure 2-2 OD124S installation size diagram

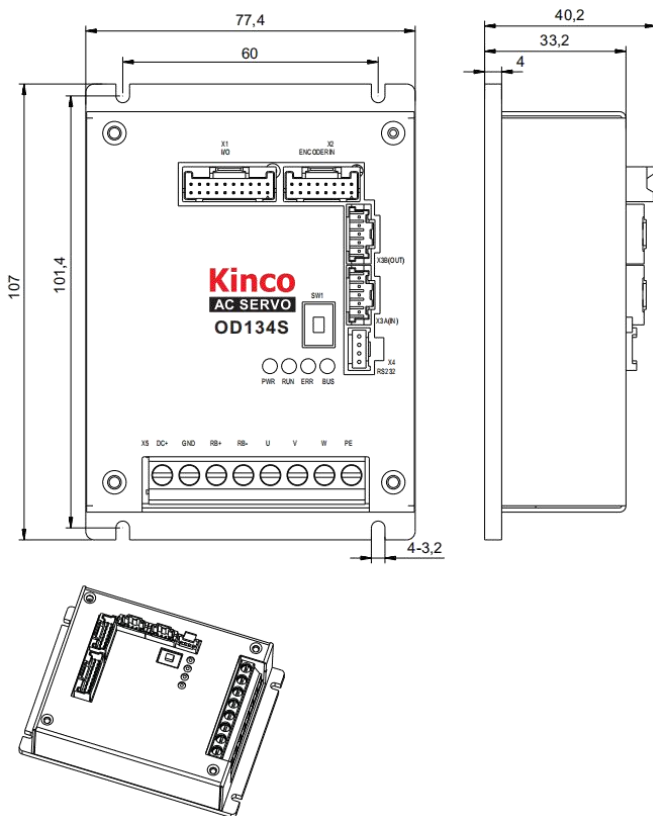


Figure 2-3 OD134S installation size diagram

2.3 External dimensions of servo motor

2.3.1 40 External dimensions of flange motor

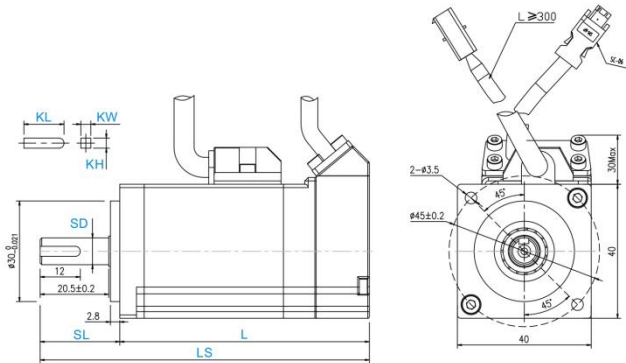


Fig. 2-4 Dimensions of 40 flange common motor

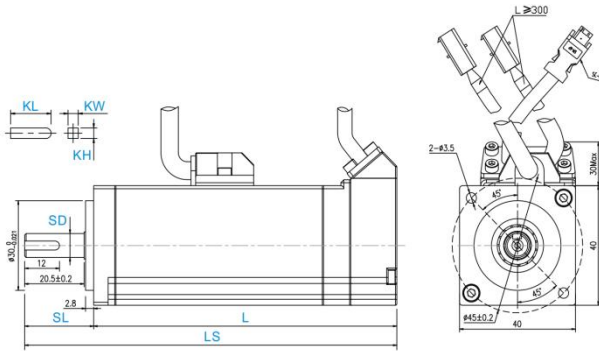


Fig. 2-5 Dimensions of 40 flanged brake motor

Flange dimensions (mm)	Servo motor	Brake	Weight (KG)	Overall dimensions (mm)			Shaft size (mm)		Key size (mm)		
				LS	L	SL	SD	Hole x Depth	KL	KW	KH
40x40	SMC40S-0005-30MAK-5DSU		0.4	98.4 ± 1.5	74.6 ± 1.5	23.8 ± 0.8	8	M3x6	12	3	3
	SMC40S-0005-30QAK-5DSU			98 ± 1.5	74.2 ± 1.5						
	SMC40S-0005-30MBK-5DSU	√	0.6	128.4 ± 1.5	104.6 ± 1.5						
	SMC40S-0005-30QBK-5DSU			128 ± 1.5	104.2 ± 1.5						
	SMC40S-0010-30MAK-5DSU		0.57	120.4 ± 1.5	96.6 ± 1.5						
	SMC40S-0010-30QAK-5DSU			120 ± 1.5	96.2 ± 1.5						
	SMC40S-0010-30MBK-5DSU	√	0.77	150.4 ± 1.5	126.6 ± 1.5						
	SMC40S-0010-30QBK-5DSU			150 ± 1.5	126.2 ± 1.5						

2.3.2 60 External dimensions of flange motor

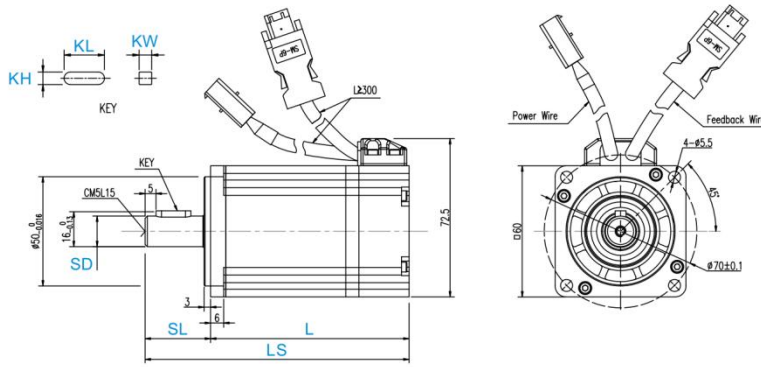


Fig. 2-6 Dimensions of 60 flange common motor

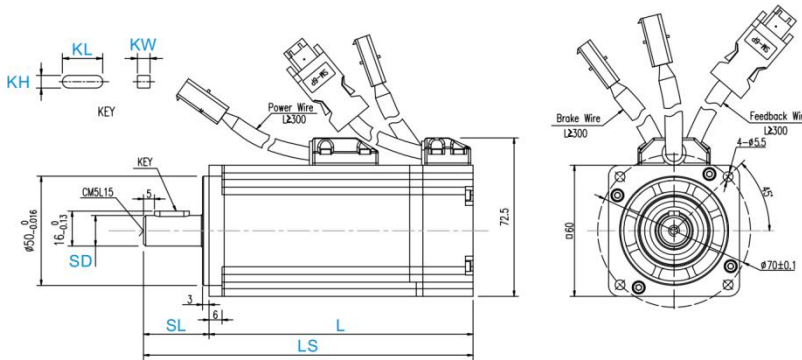


Fig. 2-7 Dimensions of 60 Flanged Brake Motor

Flange dimensions (mm)	Servo motor	Brake	Weight (KG)	Overall dimensions (mm)			Shaft size (mm)		Key size (mm)		
				LS	L	SL	SD	Hole x Depth	KL	KW	KH
60x60	SMC60S-0020-30MAK-5DSU	√	0.9	105±1.5	75±1.5	30±1	14	M5x15	16	5	5
	SMC60S-0020-30QAK-5DSU			116.5±1.5	86.5±1.5						
	SMC60S-0020-30AAK-5DSH		0.6	81.5±1.5	51.5±1.5						
	SMC60S-0020-30WAK-5DCH			142.5±1.5	112.5±1.5						
	SMC60S-0020-30MBK-5DSU	√	1.2	152.5±1.5	122.5±1.5						
	SMC60S-0020-30QBK-5DSU			127±1.5	97±1.5						
	SMC60S-0020-30ABK-5DSH			138.5±1.5	108.5±1.5						
	SMC60S-0020-30WBK-5DCH	√	1.2	114±1.5	84±1.5						
	SMC60S-0040-30MAK-5DSU			101.5±1.5	71.5±1.5						
	SMC60S-0040-30QAK-5DSU			164.5±1.5	134.5±1.5						
	SMC60S-0040-30AAK-5DSH	√	1.6	174±1.5	144±1.5						
	SMC60S-0040-30QBK-5DSU			174±1.5	144±1.5						
	SMC60S-0040-30ABK-5DSH			134±1.5	104±1.5						
	SMC60S-0040-30WBK-5DCH	√	1.4	167.5±1.5	132.5±1.5						
	SMC60S-0060-30MAK-5DSU			197.5±1.5	167.5±1.5						
	SMC60S-0060-30QAK-5DSU			174±1.5	144±1.5						
	SMC60S-0060-30AAK-5DSH	√	1.9	197.5±1.5	167.5±1.5						
	SMC60S-0060-30MBK-5DSU			207±1.5	177±1.5						
SMC60S-0060-30QBK-5DSU	197.5±1.5			167.5±1.5							
SMC60S-0060-30ABK-5DSH	√	2.3	207±1.5	177±1.5							
SMC60S-0060-30WBK-5DCH			197.5±1.5	167.5±1.5							

2.3.3 80 External dimensions of flange motor

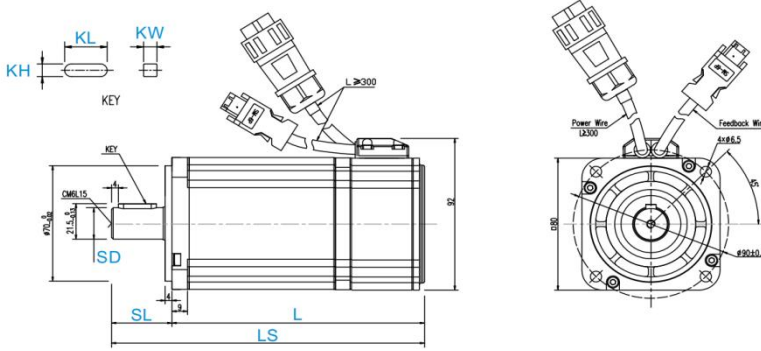


Fig. 2-8 Dimensions of 80 Flange Common Motor

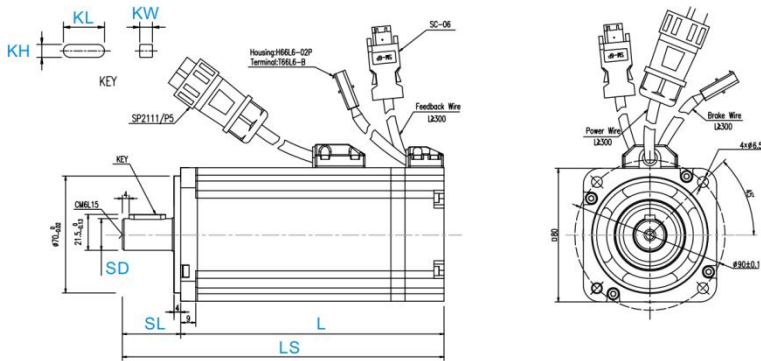
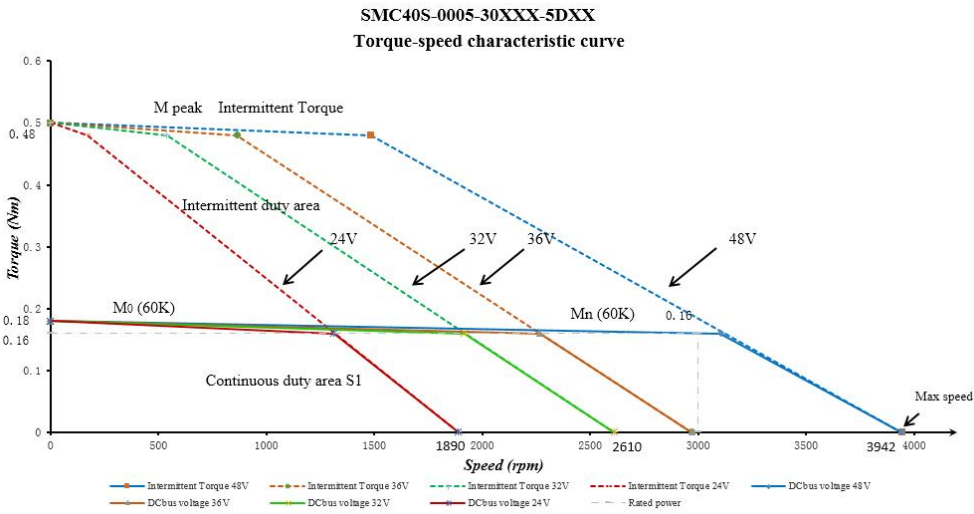


Fig. 2-9 Dimensions of 80 Flanged Brake Motor

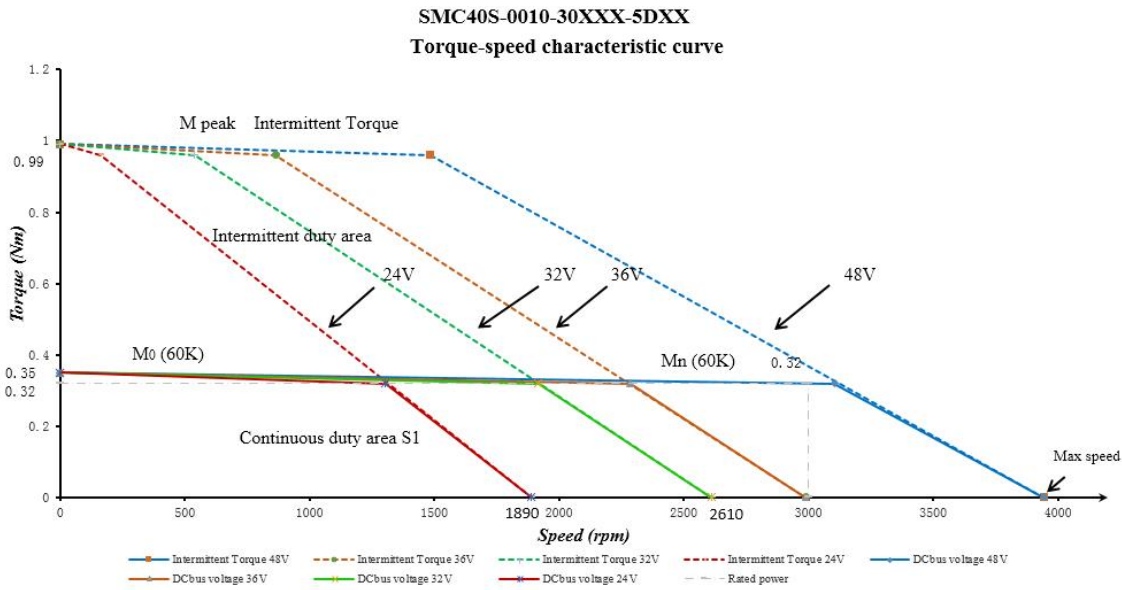
Flange dimensions (mm)	Servo motor	Brake	Weight (KG)	Overall dimensions (mm)			Shaft size (mm)		Key size (mm)		
				LS	L	SL	SD	Hole x Depth	KL	KW	KH
80x80	SMC80S-0075-30MAK-5DSU	√	2.3	141.7±1.5	106.7±1.5	35±1	19	M6x15	22	6	6
	SMC80S-0075-30QAK-5DSU		2.5								
	SMC80S-0075-30AAK-5DSH		2.4								
	SMC80S-0075-30WAK-5DCH		1.8								
	SMC80S-0075-30MBK-5DSU	√	3	176±1.5	141±1.5						
	SMC80S-0075-30QBK-5DSU		3.2	185±1.5	150±1.5						
	SMC80S-0075-30ABK-5DSH		2.9	151.9±1.5	116.9±1.5						
	SMC80S-0100-30MAK-5DSU	√	2.8	157.7±1.5	122.7±1.5						
	SMC80S-0100-30QAK-5DSU		3	169.2±1.5	134.2±1.5						
	SMC80S-0100-30AAK-5DSH		2.2	130.5±1.5	95.5±1.5						
	SMC80S-0100-30WAK-5DCH		3.3	192±1.5	157±1.5						
	SMC80S-0100-30MBK-5DSU	√	3.6	201±1.5	166±1.5						
	SMC80S-0100-30QBK-5DSU		3	163.9±1.5	128.9±1.5						
	SMC80S-0100-30ABK-5DSH		2.8	169±1.5	134.2±1.5						
	SMC80S-0120-30AAK-5DSH	√	3.3	201±1.5	166±1.5						

2.4 Servo motor torque curve

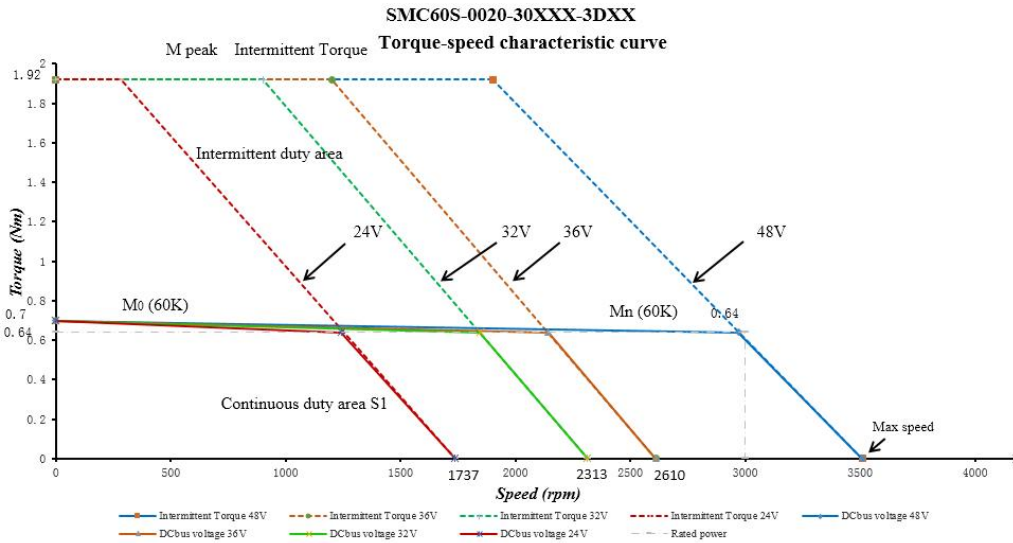
2.4.1 50W servo motor torque curve



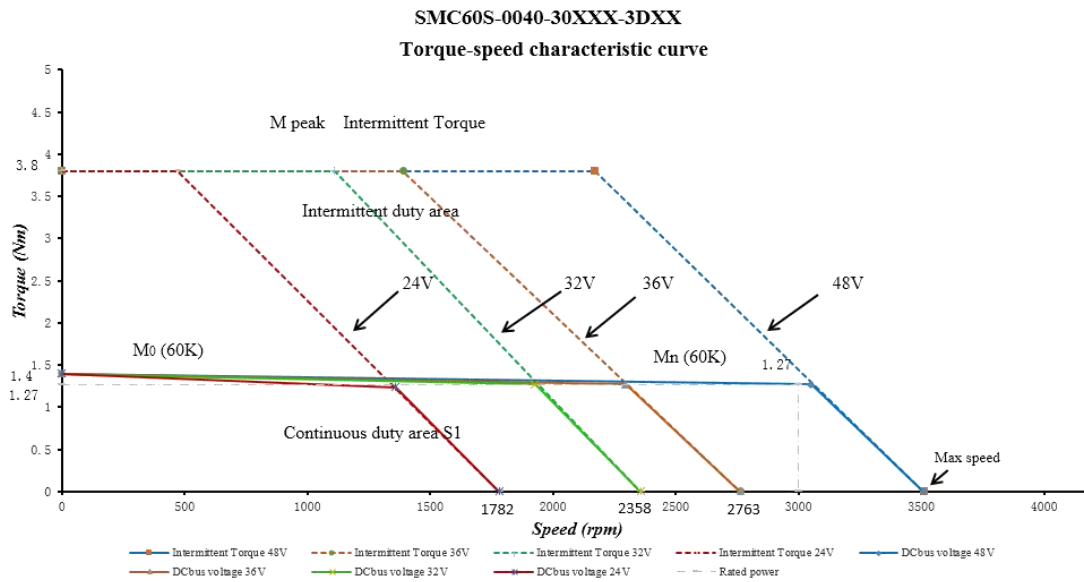
2.4.2 100W servo motor torque curve



2.4.3 200W servo motor torque curve

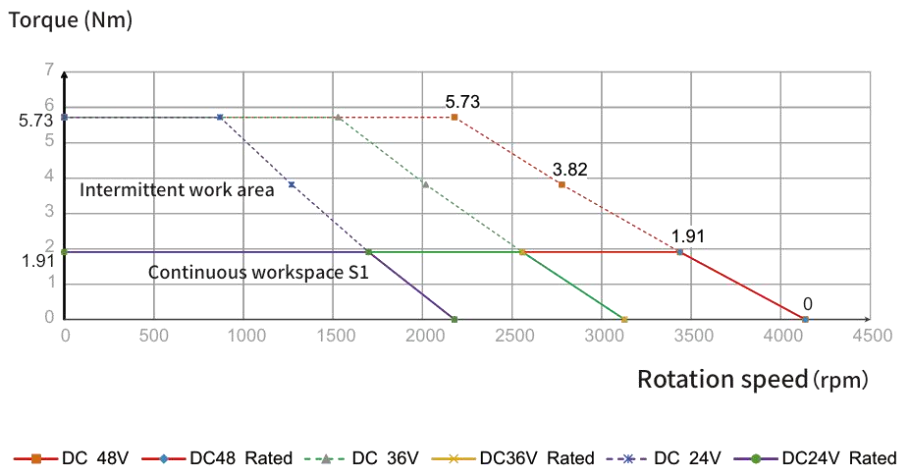


2.4.4 400W servo motor torque curve

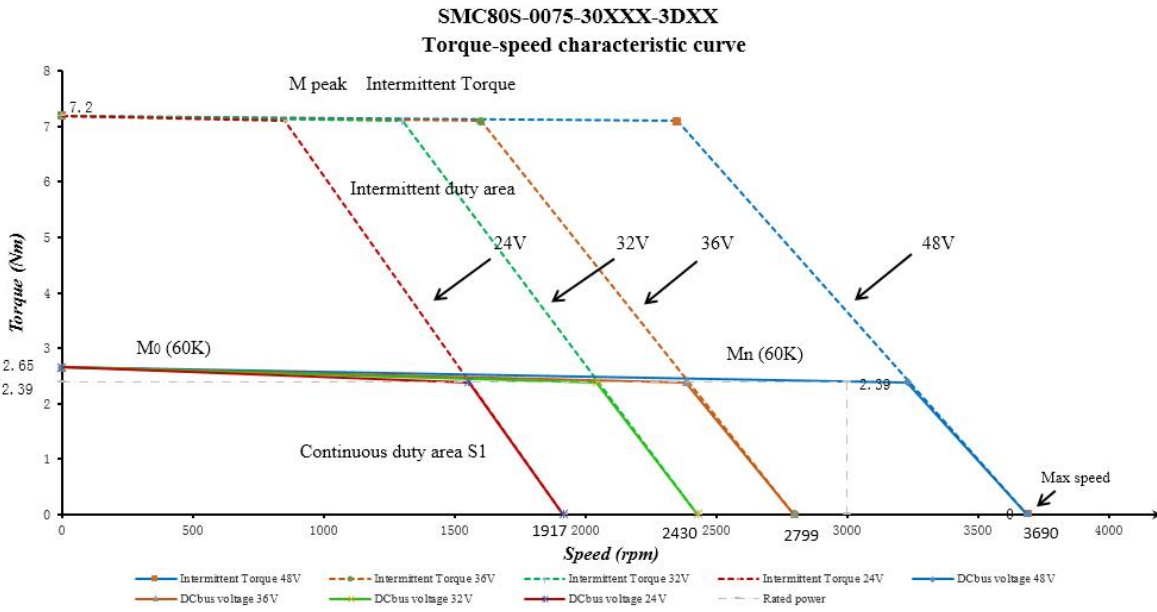


2.4.5 600W servo motor torque curve

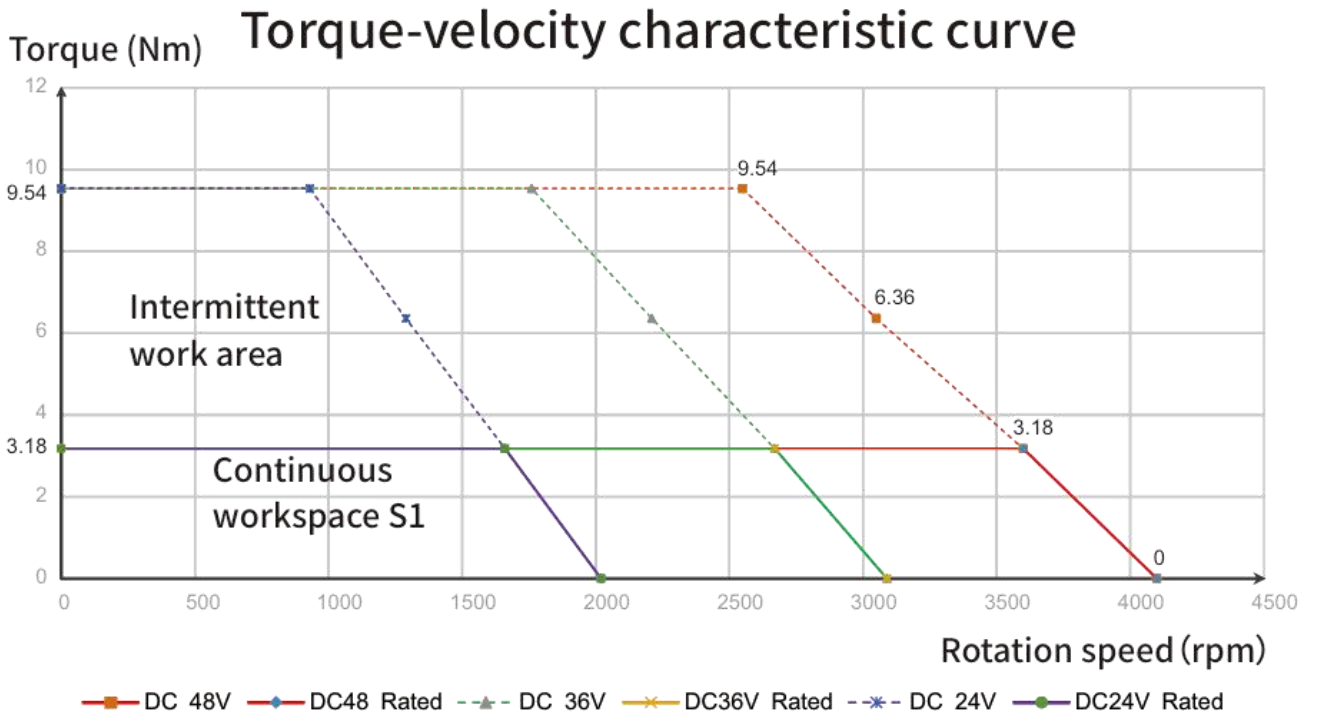
Torque-velocity characteristic curve



2.4.6 750W servo motor torque curve



2.4.7 1000W servo motor torque curve



Chapter 3 System Interface and Wiring

3.1 Name of OD servo parts

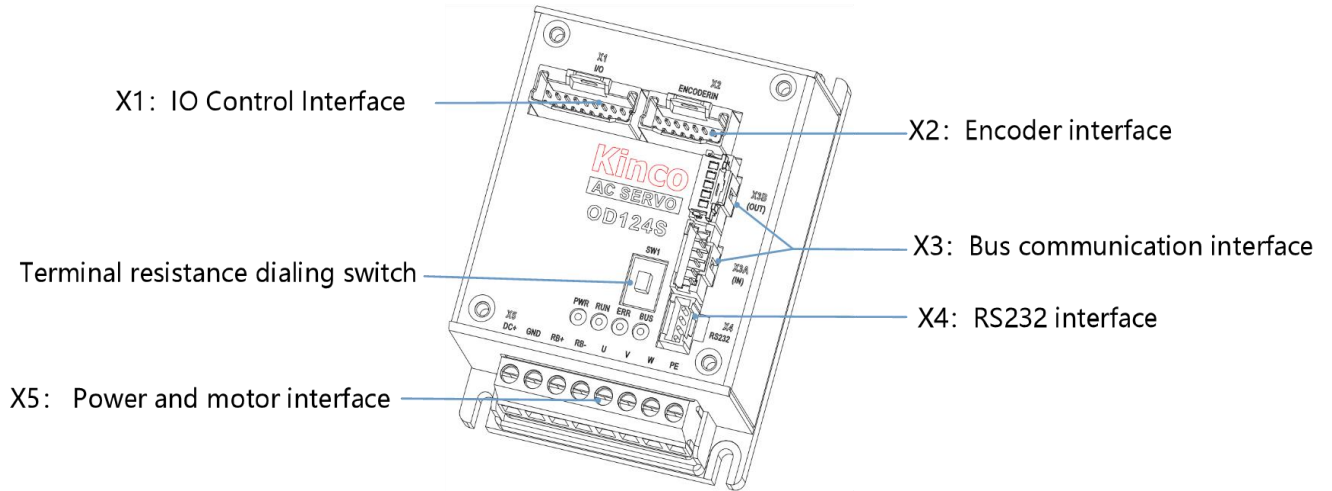


Figure 3-1 OD servo interface definitions

3.2 External wiring mode

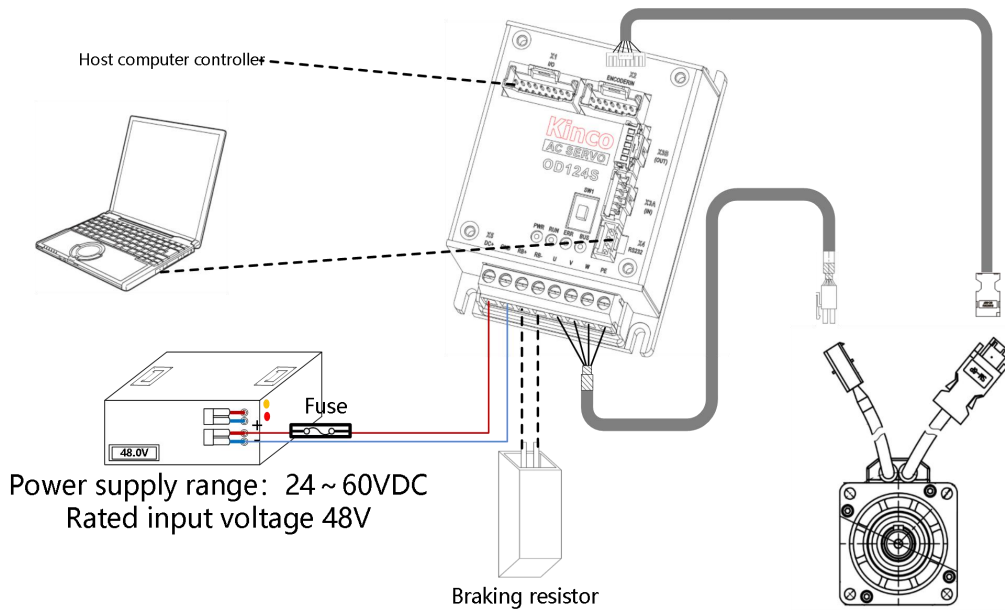


Figure 3-2 OD1X4S external connection mode

**Note**

- OD114S/124S/134S - CA/LA- 000 drive SW1 switch for the bus terminal resistance, resistance to ON when he will be 120 euro in parallel ON the bus, to OFF when disconnected.
- OD114S/124S/134S-EA-000 drive no SW1 dial the code switch.
- Please refer to Appendix 1 for the instructions of the driver cable crimping.

Table 3-1 Recommended fuse specifications

Servo driver model	Output power (unit :W)	Fuse reference specification
OD114S	50~100	10A/58VDC
OD124S	50~400	20A/58VDC
OD134S	750	40A/58VDC

Table 3-2 Recommended specifications for power cables



Product model	DC+, GND power wiring specifications	Interface drawing
OD114S/ OD124S	Range of crimping terminal wiring specifications: 0.5~2.5mm ² (24~12AWG) Recommended cross sectional area of conductor: 2~2.5mm ² (14~12AWG) Stripping Length: 6~7mm	
OD134S	Range of crimping terminal wiring specifications: 0.2~4mm ² (26~10AWG) Recommended cross sectional area of conductor: 2.5~4mm ² (12~10AWG) Stripping Length: 10~11mm	

Table 3-3 Specification of Communication Cables

Interface	Wiring specification
IO interface	Recommended cross sectional area of conductor: 0.126~0.34mm ² (22~26AWG) Stripping Length: 1~1.5mm
Encoder interface	Recommended cross sectional area of conductor: 0.126~0.34mm ² (22~26AWG) Stripping Length: 1~1.5mm
Bus interface	Recommended cross sectional area of conductor: 0.2~0.34mm ² (22~28AWG) Stripping Length: 1~1.5mm

3.3 Interface and cable instruction

3.3.1 External input output interface (X1)

Table 3-4 Interface X1 Definition

	PIN	Signal	Description
	<p>Wiring surface schematic diagram</p>	1	GND
15		GND	Voltage: 24VDC; Current: 1A
2		24V+	Note: Both Pin1 and Pin15 are GND, there is no difference. Please be able to wiring nearby
3		OUT2-	Digital signal output Maximum output current: 100mA
5		OUT2+	
7		OUT1-	
9		OUT1+	
11		AIN-	Analog input: $\pm 10V$
13		AIN+	Accuracy: 12 bits
17		OUT5-	The brake output needs to be connected to 24VDC externally, and the maximum driving current is 500mA
19		OUT5+	
4		DIR-	Input voltage: 3.3V to 24V Maximum frequency: 500KHz
6		DIR+	
8		PUL-	
10		PUL+	
12		IN4	Digital signal input
14		IN3	High level: 12.5VDC to 30VDC
16		IN2	Low level: 0VDC to 5VDC
18		IN1	Input impedance: 5K Ω Input frequency: <1KHz
20		COMI	Digital signal input common end

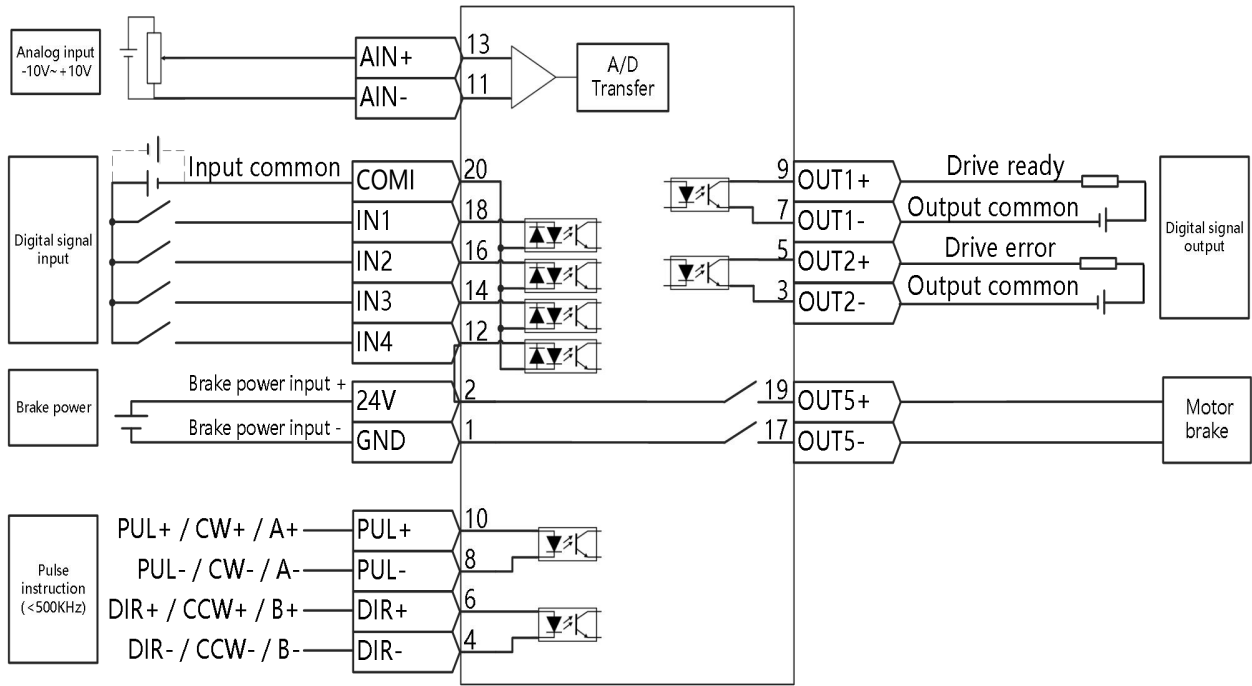


Fig. 3-3 Wiring Diagram of External I/O Outlet



Note

- Fig. 3-3 Output outlet is NPN connection mode, while PNP connection mode is shown in Fig. 3-4.

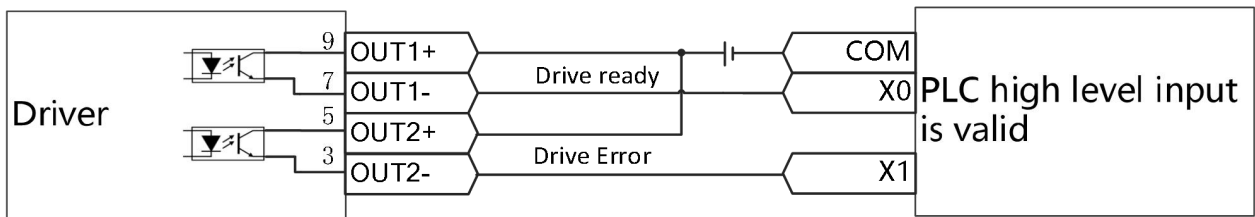
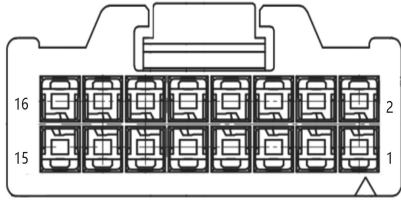


Fig. 3-4 PNP wiring diagram of the output port

3.3.2 Encoder interface (X2)

Table 3-5 Pin definition of X2 interface for motor with incremental encoder

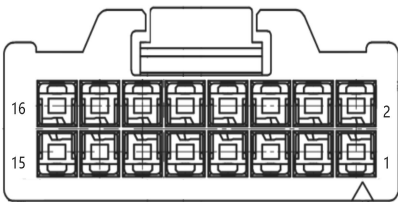
PIN	Signal	Description	
		Signal	Description
1	PTC_IN	Temperature sensor signal	
3	W	Encoder phase W singal	input terminal
4	/W	Encoder phase W singal	input terminal
5	V	Encoder phase V singal	input terminal
6	/V	Encoder phase V singal	input terminal
7	U	Encoder phase U singal	input terminal
8	/U	Encoder phase U singal	input terminal
9	Z	Encoder phase Z singal	input terminal
10	/Z	Encoder phase Z singal	input terminal
11	B	Encoder phase B singal	input terminal
12	/B	Encoder phase B singal	input terminal
13	A	Encoder phase A singal	input terminal
14	/A	Encoder phase A singal	input terminal
15	5V+	5V power supply voltage output	
16	GND	Encoder signal ground terminal	



Wiring surface schematic diagram

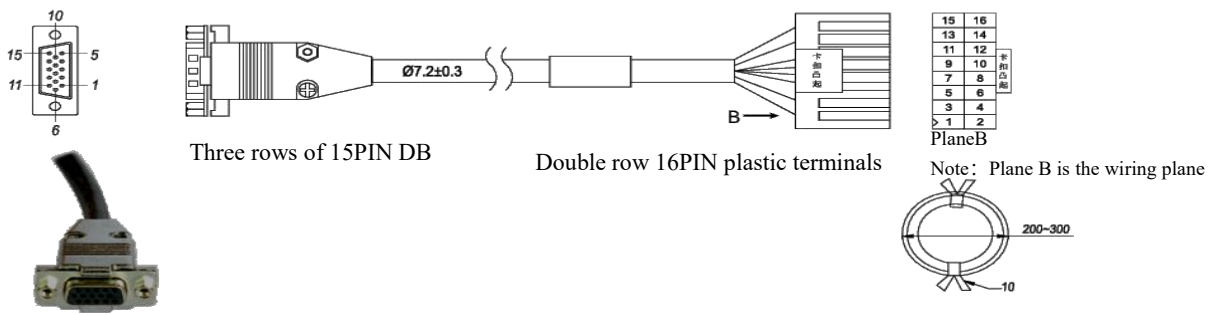
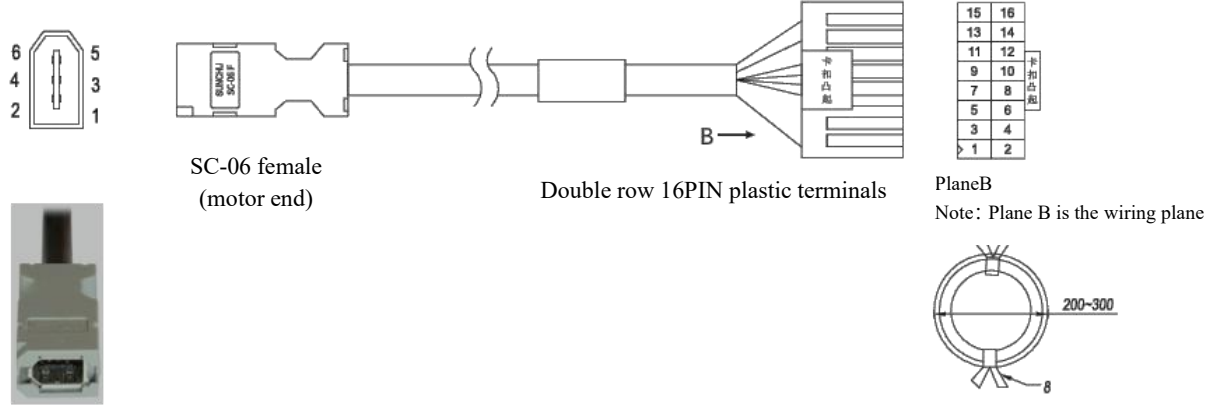
Table 3-6 Pin definition of X2 interface for motor with communication encoder

PIN	Signal	Description	
3	SLO_P+	Data signal positive end	
4	SLO_N-	Data signal negative end	
5	MA_P+	Clock signal positive end	
6	MA_N-	Clock signal negative end	
15	5V+	Encoder 5V supply voltage output	
16	GND	Encoder 5V power grounding terminal	



Wiring surface schematic diagram

Table 3-7 Encoder cable terminal definition

ENCOA-LL-KH			
<p>Cable specification: 24AWG/1P+28AWG/7P+AB 1061 24AWG corresponds to a cross-sectional area of 0.2047mm² 28AWG corresponds to a cross-sectional area of 0.0804mm²</p>  <p>Three rows of 15PIN DB</p> <p>Double row 16PIN plastic terminals</p> <p>Note: Plane B is the wiring plane</p>			
Three rows of 15PIN DB (motor end)	Pin name	Cable color	Double row 16PIN plastic terminals (drive end)
1	5V+	Red	15
8	A	Orange	13
7	B	Yellow	11
6	Z	Green	9
4	U	Brown	7
10	V	Purple	5
9	W	Blue	3
2	GND	Black	16
13	/A	Orange and white	14
12	/B	Yellow and white	12
11	/Z	Green and white	10
5	/U	Brown and white	8
15	/V	Purple and white	6
14	/W	Blue and white	4
Shell	Shiled	Shielded cable	2
ENCOG-LL-GU			
 <p>SC-06 female (motor end)</p> <p>Double row 16PIN plastic terminals</p> <p>Note: Plane B is the wiring plane</p>			

SC-06 female (motor end)	Signal 1 (Suitable for magnetolectric encoder)	Signal 2 (Suitable for absolute value encoder)	Cable color	Double row 16PIN plastic terminals (drive end)
1	VDD	VDD	Red	15
2	GND	GND	Black	16
3	MA_P+	BAT+	Brown	5
4	MA_N-	BAT-	Blue	6
5	SLO_P+	SD	Yellow	3
6	SLO_N-	/SD	Green	4
Shell	Shiled	Shield	Shield	2

3.3.3 Bus communication interface (X3)

Table 3-8 RS485 communication interface pin definition

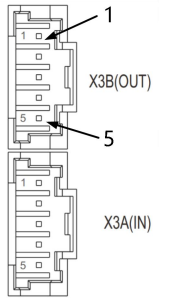
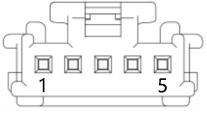
 RS485 communication port socket shape diagram	Pin number	Pin Name	Pin function
	1	RX+	Positive received data
2	RX-	Negative received data	
3	TX-	Negative send data	
4	TX+	Positive send data	
5	GND	GND	

Table 3-9 RS485 communication wiring mode

RS485 plug pin definition	Pin Name(Drive)	Pin Number(Drive)	Pin Name(PLC)
	RX+	1	RS485+
	TX+	4	
	RX-	2	RS485-
	TX-	3	
	GND	5	GND

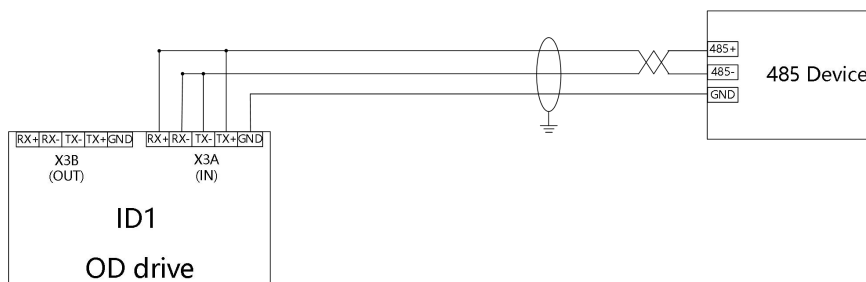


Figure 3-5. Point-to-point 485 communication connection diagram

Table 3-10 CAN communication interface pin definition

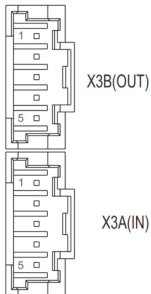
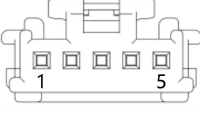
 <p>Outline drawing of CAN communication outlet socket</p>	Pin number	Pin Name	Pin function
	1	\	\
	2	CAN_H	
	3	CAN_L	
	4	\	\
	5	GND	GND

Table 3-11 Wiring mode of CAN communication

CAN plug pin definition	Pin Name(Drive)	Pin Number(Drive)	Pin Name(PLC)
	CAN_H	2	CAN_H
	CAN_L	3	CAN_L
	GND	5	GND

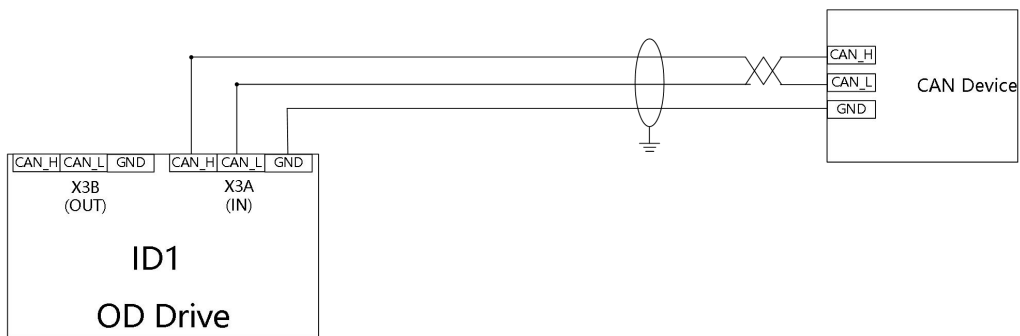


Figure 3-6. Point-to-point CAN communication connection diagram

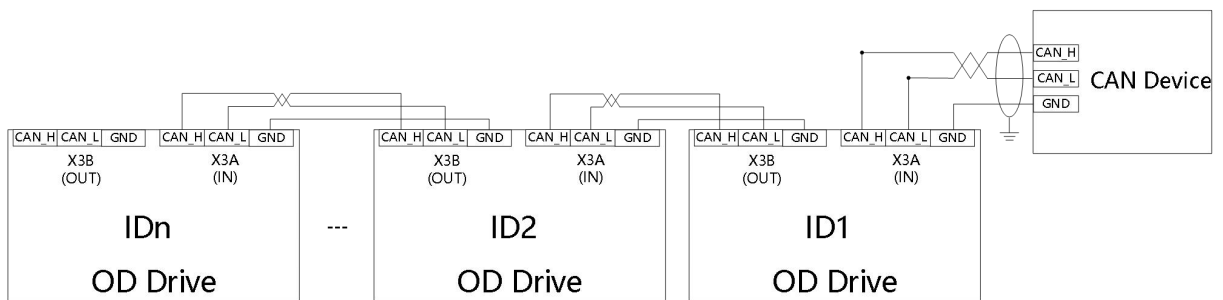


Figure 3-7. Diagram of point-to-multipoint CAN communication connection

Table 3-12 EtherCAT communication interface pin definition

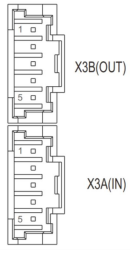
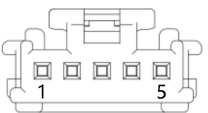
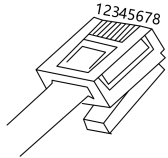
 Ethercat communication port socket appearance diagram	Pin number	Pin Name	Pin function
	1	RX+	Positive received data
	2	RX-	Negative received data
	3	TX+	Positive send data
	4	TX-	Negative send data
5	GND	GND	

Table 3-13 Wiring mode of EtherCAT communication

Drive ECAN plug Pin definition	Pin Name(Drive)	Pin Number(Drive)	Pin Name(PLC)	Pin Number(RJ45)	Cable pin distribution
	RX+	1	TX+	1	
	RX-	2	TX-	2	
	TX+	3	RX+	3	
	TX-	4	RX-	6	

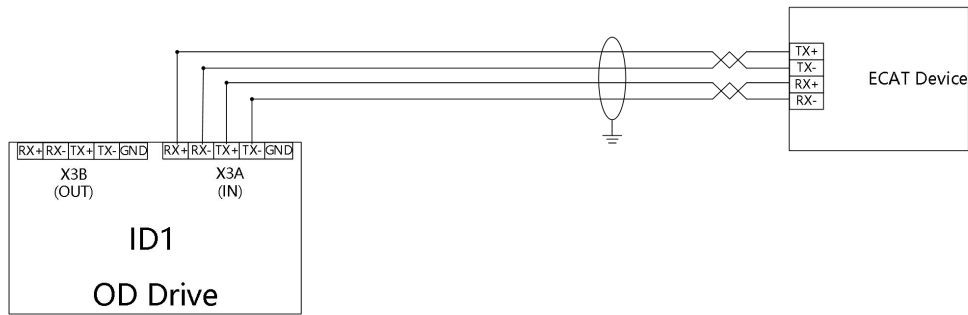


Figure 3-8 point-to-point EtherCAT communication connection diagram

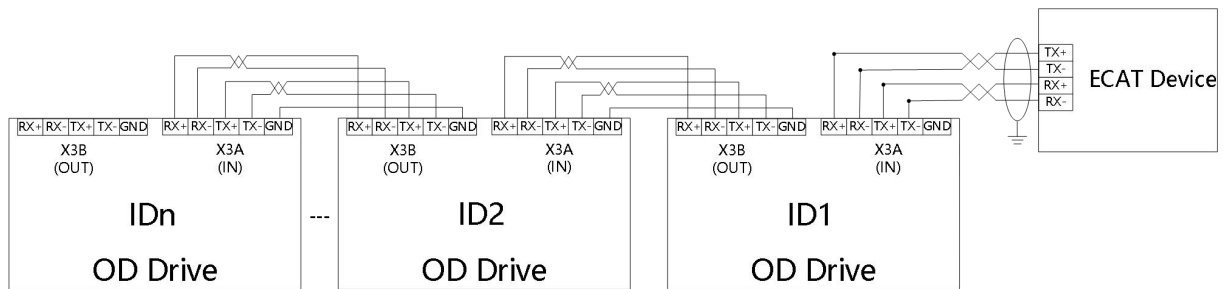


Figure 3-9 point-to-multipoint EtherCAT communication connection diagram

3.3.4 232 Communication serial port (X4)

Table 3-14 RS232 communication interface pin definition

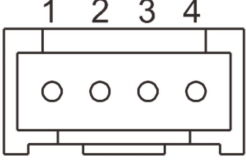
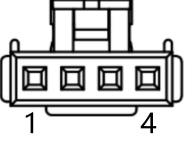
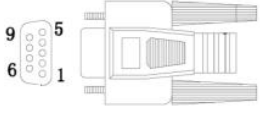
 <p>RS232 communication port socket appearance diagram</p>	Pin number	Pin Name	Pin function
	1	GND	GND
	2	GND	GND
	3	TX	Drive send data
	4	RX	Drive received data

Table 3-15 Wiring mode of RS232 communication

Drive RS232 Pin definition	Pin Name(Drive)	Pin Number(Drive)	Pin Name(PC)	Pin Number(PC)	Pin definition(PC)
	TXD	3	Received data(RXD)	2	
	RXD	4	Send data(TXD)	3	
	GND	1	GND	5	

Users can purchase Buke OD drive 232 debugging cable to connect to the PC serial port for debugging. The specification of the debugging line is OD124RS232-0.5m

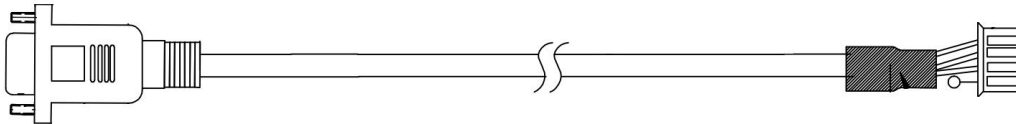


Figure 3-10. Diagram of RS232 Debugging Line of OD Driver

3.3.5 Power interface (X5)

Table3-16 X5 interface definition

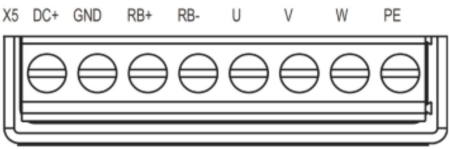
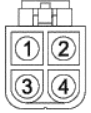
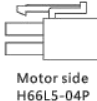
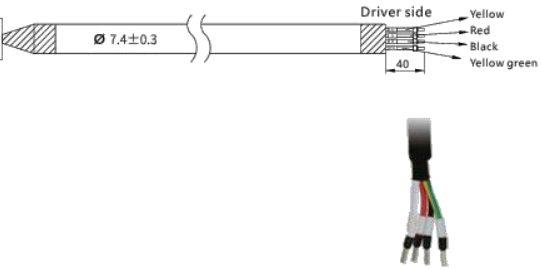

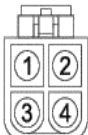
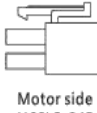
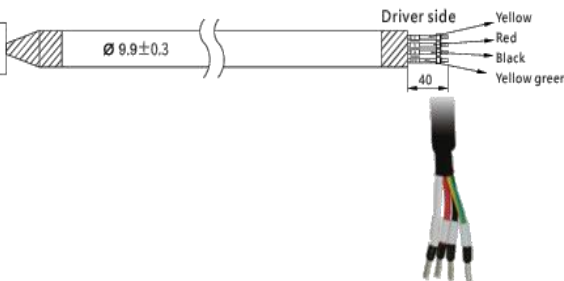


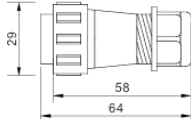
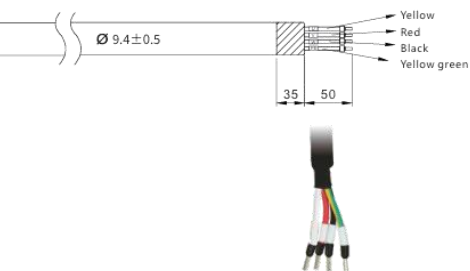


 <p>X5 terminal distribution diagram</p>	Pin Name	Pin function
	DC+	DC power input terminal (24-60V)
	GND	
	RB+	External brake resistor
	RB-	
	U	Servo motor UVW Phase line connection end
	V	
	W	
PE	GND	

Table3-17 Power cable

MOT-005-LL-KL-D																							
<p>Wire spec: 4C×18AWG(41/0.16T)-PVC 18AWG cross sectional area 0.8107mm²</p>																							
 <p>4PIN terminal</p>	 <p>Motor side H66L5-04P</p>	 <p>Driver side 40 Yellow Red Black Yellow green</p>																					
																							
<table border="1"> <thead> <tr> <th colspan="3">MOT-005-LL-KL-D</th> </tr> <tr> <th>Color</th> <th>Signal</th> <th>4PIN plug</th> </tr> </thead> <tbody> <tr> <td>white</td> <td>U</td> <td>PIN1</td> </tr> <tr> <td>Red</td> <td>V</td> <td>PIN2</td> </tr> <tr> <td>Black</td> <td>W</td> <td>PIN3</td> </tr> <tr> <td>Yellow green</td> <td>PE</td> <td>PIN4</td> </tr> </tbody> </table>			MOT-005-LL-KL-D			Color	Signal	4PIN plug	white	U	PIN1	Red	V	PIN2	Black	W	PIN3	Yellow green	PE	PIN4			
MOT-005-LL-KL-D																							
Color	Signal	4PIN plug																					
white	U	PIN1																					
Red	V	PIN2																					
Black	W	PIN3																					
Yellow green	PE	PIN4																					
MOT-008-LL-KL-D																							
<p>Wire spec: 4×16AWG 16AWG cross sectional area 1.318mm²</p>																							
 <p>H66L5-04P</p>	 <p>Motor side H66L5-04P</p>	 <p>Driver side 40 Yellow Red Black Yellow green</p>																					
																							
<table border="1"> <thead> <tr> <th colspan="3">MOT-008-LL-KL-D</th> </tr> <tr> <th>Color</th> <th>Signal</th> <th>H66L5-04P</th> </tr> </thead> <tbody> <tr> <td>white</td> <td>U</td> <td>PIN1</td> </tr> <tr> <td>Red</td> <td>V</td> <td>PIN2</td> </tr> <tr> <td>Black</td> <td>W</td> <td>PIN3</td> </tr> <tr> <td>Yellow green</td> <td>PE</td> <td>PIN4</td> </tr> </tbody> </table>			MOT-008-LL-KL-D			Color	Signal	H66L5-04P	white	U	PIN1	Red	V	PIN2	Black	W	PIN3	Yellow green	PE	PIN4			
MOT-008-LL-KL-D																							
Color	Signal	H66L5-04P																					
white	U	PIN1																					
Red	V	PIN2																					
Black	W	PIN3																					
Yellow green	PE	PIN4																					
MOT-015-LL-KL-SP-1																							
<p>Wire spec: 4×14AWG(50/0.25T) 14AWG cross sectional area 2.075mm²</p>																							
 <p>29</p>	 <p>29 58 64</p>	 <p>Driver side 35 50 Yellow Red Black Yellow green</p>																					
																							
<table border="1"> <thead> <tr> <th colspan="3">MOT-015-LL-KL-SP-1</th> </tr> <tr> <th>Color</th> <th>Signal</th> <th>5PIN Air insertion</th> </tr> </thead> <tbody> <tr> <td>white</td> <td>U</td> <td>PIN1</td> </tr> <tr> <td>Red</td> <td>V</td> <td>PIN2</td> </tr> <tr> <td>Black</td> <td>W</td> <td>PIN3</td> </tr> <tr> <td>Yellow green</td> <td>PE+Shielding</td> <td>PIN4</td> </tr> <tr> <td>NC</td> <td>NC</td> <td>PIN5</td> </tr> </tbody> </table>			MOT-015-LL-KL-SP-1			Color	Signal	5PIN Air insertion	white	U	PIN1	Red	V	PIN2	Black	W	PIN3	Yellow green	PE+Shielding	PIN4	NC	NC	PIN5
MOT-015-LL-KL-SP-1																							
Color	Signal	5PIN Air insertion																					
white	U	PIN1																					
Red	V	PIN2																					
Black	W	PIN3																					
Yellow green	PE+Shielding	PIN4																					
NC	NC	PIN5																					

3.3.6 Driver indicator

Table 3-18 Driver working indicator light

	Name	Function
	PWR	The driver is powered on, and the POWER lamp is always on
	RUN	The drive is always on when ready and is associated with out3
	ERR	The drive is always on when ready and is associated with out4
	BUS	CANopen bus will flash when there is a message transmission, the flashing frequency is related to the transmission speed of the message



Note

- Out3 defines drive ready by default, out4 defines drive failure by default. When the RUN and ERR indicator lights are not on, check whether the default definition has been modified.

Chapter 4 Working mode introduction

The RS232 interface can be connected to PC to set the parameters of OD driver. The Servo debugging software Kinco Servo+ can be downloaded from the official website of the Kinco

4.1 Trial operation

Step 1: Hardware wiring

Please confirm whether the hardware wiring is correct before the trial operation. Please refer to the wiring instructions in Chapter 3 for specific hardware wiring methods

Step 2: Drive I/O software configuration

Please confirm the I/O configuration before trial operation. The default DIN digital input of OD drive has no configuration function. If the ENABLED signal is defined in the DIN port, the control word cannot be written in the basic operation interface to control the ENABLED function. The DIN setting function can be cleared before trial operation.

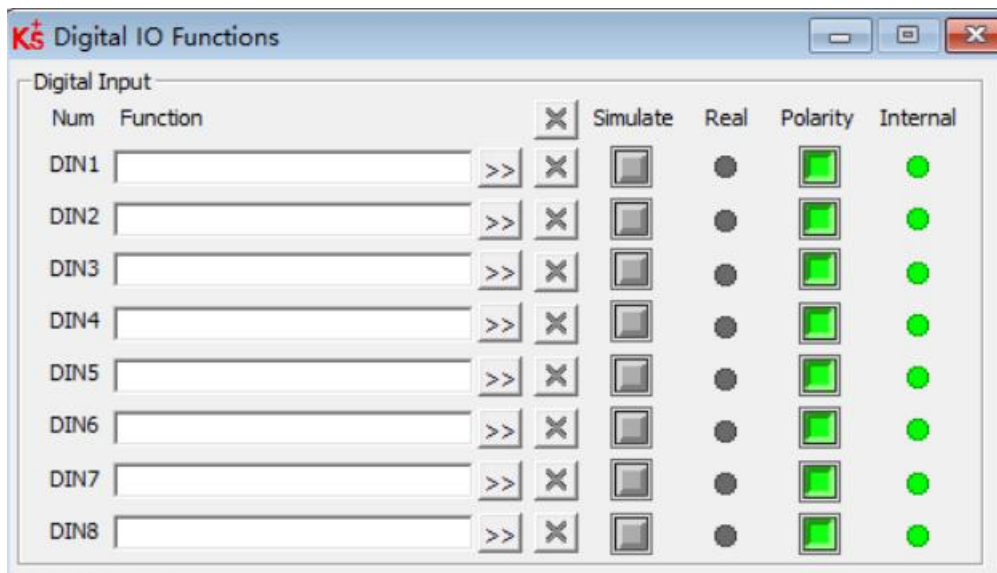


Figure 4-1 Digital IO Settings Window

Step 3: Set relevant parameters

In Ks + PC software interface, click on the **Motor - > Motoe setting**, according to the Motor nameplate of Motor code input model drive and click **Driver - >Init Save Rebot** to initialize store interface by clicking on it - restart Motor parameters, after confirm the identity of the current Motor model and Motor model, in turn, click on

the initialization, storage control parameters, control parameters to restart to complete configuration. Note that the control parameters must be initialized after the motor is configured, otherwise the phenomenon of abnormal no-load operation may occur.

Table 4-1 Motor configuration parameters

Internal Address	Bits	Name	Description	Setting Value
64100110	Unsigned16	Motor_Num	Enter the Motor code on the motor nameplate. If you cannot view the motor nameplate, you can find the code through Help -> More Motors	User Settings
64101610	Unsigned16	Motor_Using	Current using motor type	RLE

After the motor is configured, click **Driver-> Basic Operation** to enter the interface of setting basic operating parameters. The test run can be carried out by following the Settings in Table 4-1 in the software.

Table 4-2 Test run parameter Settings

Internal Address	Bits	Name	Description	Setting Value
60600008	Integer8	Operation_Mode	3:Speed Control	3、
60400010	Unsigned16	Controlword	0x0F: Used when operating mode is -3, 3 mode 0x86: Used when resetting a drive failure 0x06: Loose axle, disable drive enable	F、 86、 6
60830020	Unsigned32	Profile_Acc	Acceleration and deceleration in mode 3, unit rps/s	100
60840020	Unsigned32	Profile_Dec		100
60FF0020	Integer32	Target_Speed	Target speed in mode 3, unit rpm	0-3000

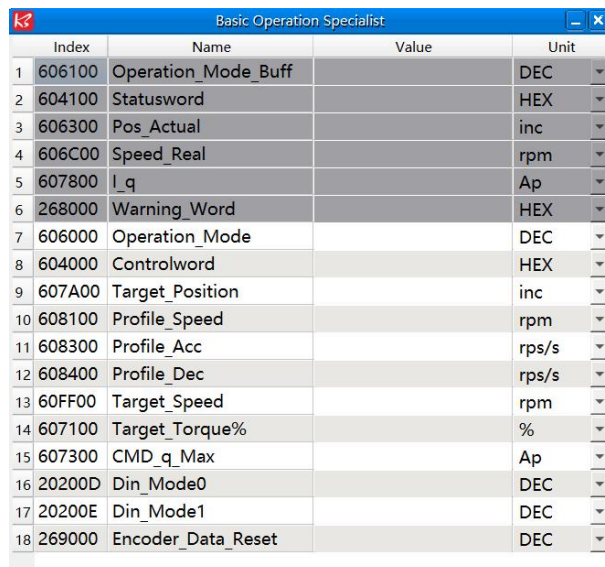
4.2 Velocity mode (-3, 3)

There are two speed modes: 3 and -3. The speed mode can be controlled by external I/O, internal instruction writing and external analog input.

Table 4-3. Parameter description of speed mode

Internal address	Type	Name	Description	value
60600020	Integer8	Operation mode	-3: The velocity command is specified directly by Target_Speed. Only the velocity control loop is active. 3: The velocity command is specified by Target_Speed with profile acceleration and profile deceleration. Velocity- and position control loops are active	-3 and 3
60400010	Unsigned16	Control word	0x0F: Enable the controller ; 0x06: Disable the controller	0x0F
60FF0020	Integer32	Target-speed	Target velocity, cannot over motor rated speed	User defined
60810020	Unsigned32	Profile_Acc	Active in mode 1 and 3	Default as 100rps/s
60830020	Unsigned.32	Profile_Dec	Active in mode 1 and 3	Default as 100rps/s

In software "**Basic operation**" window, we can find these parameters and set.



Index	Name	Value	Unit
1	606100	Operation_Mode_Buff	DEC
2	604100	Statusword	HEX
3	606300	Pos_Actual	inc
4	606C00	Speed_Real	rpm
5	607800	I_q	Ap
6	268000	Warning_Word	HEX
7	606000	Operation_Mode	DEC
8	604000	Controlword	HEX
9	607A00	Target_Position	inc
10	608100	Profile_Speed	rpm
11	608300	Profile_Acc	rps/s
12	608400	Profile_Dec	rps/s
13	60FF00	Target_Speed	rpm
14	607100	Target_Torque%	%
15	607300	CMD_q_Max	Ap
16	20200D	Din_Mode0	DEC
17	20200E	Din_Mode1	DEC
18	269000	Encoder_Data_Reset	DEC

Figure 4-2 Basic operation window

4.2.1 Analog speed mode

The analog speed object window in the PC software can be accessed via menu item **Controller->Basic operation->Control Modes->Analog Speed Mode**.

Table 4-4. Explanation of parameters related to the simulated speed mode

Internal address	Type	Name	Description	Value
250.0610	Unsigned16	ADC1_Buff[1]	AIN1 input real data	Only read
25020F10	Integer16	Analog1_out	AIN1 valid input; analog input signal1 (AIN1) input voltage after filter, deadband and offset	
25010710	Unsigned16	ADC2_Buff[1]	AIN2 input real data	
25021010	Integer16	Analog2_out	AIN2 valid input; analog input signal2 (AIN2), input voltage after filter, deadband and offset	
25020110	Unsigned16	Analog1_Filter	AIN1 filter (unit: ms)	User defined
2FF01D10	Integer16	Analog1_Death_V	AIN1 deadband (unit: 0.01V)	
2FF01E10	Integer16	Analog1_Offset_V	AIN1 offset (unit: 0.01V)	
25020410	Unsigned16	Analog2_Filter	AIN2 filter (unit: ms)	
2FF01F10	Integer16	Analog2_Death_V	AIN2 deadband (unit: 0.01V)	
2FF02010	Integer16	Analog2_Offset_V	AIN2 offset (unit: 0.01V)	
25020A10	Integer16	Analog_Speed_Factor	AIN speed factor	1 or 2
25020708	Unsigned8	Analog_Speed_Con	0: analog velocity control OFF, velocity control via Target_Speed(60FF.00) 1: Speed control via AIN1 2: Speed control via AIN2	

25020D10	Integer16	Analog_Dead_High	Default is 0, if it's NOT 0, Analog_out> Analog_Dead_High is treated as 0	User defined
25020E10	Integer16	Analog_Dead_Low	Default is 0, if it's NOT 0, Analog_out< Analog_Dead_Low is treated as 0	
60600008	Integer8	Operation mode	Select the working mode according to the actual control mode	
60400010	Unsigned16	Controlword	Driver enable	

	name	data	unit
1*	ADC1_Buff[1]		DEC
2*	Analog1_out		U
3*	ADC2_Buff[1]		DEC
4*	Analog2_out		U
5	Analog1_Filter		DEC
6	Analog1_Dead		U
7	Analog1_Offset		U
8	Analog2_Filter		DEC
9	Analog2_Dead		U
10	Analog2_Offset		U
11	Analog_Speed_Factor		rpm/v
12	Analog_Speed_Con		DEC

Fig. 4-3 Simulation speed mode window

For convenience, some new names are used in the formula. Definitions:

AIN1_in: AIN1 input voltage after filter and offset

AIN2_in: AIN2 input voltage after filter and offset

Analog_out: Analog1_out or Analog2_out, depends on wiring and Analog_Speed_Con setting;

It' s the result of AIN real input, filter, offset and deadband.

Final result:

Analog_Speed control ON:

If Analog_out is not limited by Analog_Dead_High or Analog_Dead_Low:

Target speed[rpm]=Analog_out[V]*Analog_Speed_Factor[rpm/V]; otherwise Target speed[rpm]=0.

Analog_MaxTorque control ON:

Max torque[Nm]=Analog_out[V]*Analog_MaxT_Factor[Nm/V]

Example:

Setting: Analog1_Dead=1V, Analog1_Offset=2V, Analog_Speed_Factor=100rpm/V,

Analog_Speed_Con=1, Analog_Dead_High=0V; Analog_Dead_Low=0V;

Where AIN1 input voltage is 5V:

$AIN1_in = 5V - 2V = 3V$, $|AIN1_in| > Analog1_Dead$, so $Analog1_out = 3V - 1V = 2V$;

Target speed = $2 * 100 = 200rpm$.

Where AIN1 input voltage is -5V:

$AIN1_in = -5V - 2V = -7V$, $|AIN1_in| > Analog1_Dead$, so $Analog1_out = -7V + 1V = -6V$;

Target speed = $-6 * 100 = -600rpm$.

4.2.2 DIN Speed mode

The Din_Speed object window in PC software can be accessed from menu item **Controller->Control Modes->DIN Speed Mode**.

To make the DIN Speed Mode available, at least one of the following has to be configured to DIN: **Din Vel Index0, Din Vel Index1, Din Vel Index2**.

Table 4-5 DIN speed mode introduction

Internal address	Type	Name	Description	Value
20200520	Integer32	Din speed[0]	The velocity command is specified via Din_Speed[x]. x is the BCD code of Bit 0: Din Vel Index0 Bit 1: Din Vel Index1 Bit 2: Din Vel Index2 A bit which is not configured means 0.	User defined
20200620	Integer32	Din speed[1]		
20200720	Integer32	Din speed[2]		
20200820	Integer32	Din speed[3]		
20201420	Integer32	Din speed[4]		
20201520	Integer32	Din speed[5]		
20201620	Integer32	Din speed[6]		
20201720	Integer32	Din speed[7]		
60830020	Integer32	Trapezoidal acceleration	When the operation_mode is 3 mode, the trapezoidal acceleration and trapezoidal deceleration must be set, otherwise the response speed segment will not be executed.	
60840020	Integer32	Trapezoidal deceleration		

Table 4-6 DIN speed index Settings

DIN speed index 0	DIN speed index 1	DIN speed index 2	Speed	Value
0	0	0	Din_Speed[0]	User defined
1	0	0	Din_Speed[1]	
0	1	0	Din_Speed[2]	
1	1	0	Din_Speed[3]	
0	0	1	Din_Speed[4]	
1	0	1	Din_Speed[5]	
0	1	1	Din_Speed[6]	
1	1	1	Din_Speed[7]	

0 means the signal is off, 1 means the signal is on.

The following points need to be noted when activating DIN speed mode:

1. DIN speed mode is only available in 3 or -3 operation_mode, invalid in other working modes.
2. Analog-speed control (250207) is 0, close the analog-speed channel.
3. The digital input in DIN defines at least one of DIN speed index 0, DIN speed index 1, DIN speed index 2 as a switching signal for the speed segment.

I/O configuration:

Num	Function	Simulate	Real	Polarity	Internal
DIN1	Enable	<input type="checkbox"/>	<input type="radio"/>	<input checked="" type="checkbox"/>	<input type="radio"/>
DIN2	Reset Errors	<input type="checkbox"/>	<input type="radio"/>	<input checked="" type="checkbox"/>	<input type="radio"/>
DIN3	Operate Mode Sel	<input checked="" type="checkbox"/>	<input type="radio"/>	<input checked="" type="checkbox"/>	<input checked="" type="radio"/>
DIN4	Din Vel Index0	<input type="checkbox"/>	<input type="radio"/>	<input checked="" type="checkbox"/>	<input type="radio"/>
DIN5	Din Vel Index1	<input checked="" type="checkbox"/>	<input type="radio"/>	<input checked="" type="checkbox"/>	<input checked="" type="radio"/>
DIN6	Din Vel Index2	<input type="checkbox"/>	<input type="radio"/>	<input checked="" type="checkbox"/>	<input type="radio"/>

Figure 4-4 IO configuration interface

	name	data	unit
1	Din_Speed0		rpm
2	Din_Speed1		rpm
3	Din_Speed2		rpm
4	Din_Speed3		rpm

Figure 4-5 IO "DIN Speed Mode" window

When DIN Speed index 1 is valid, DIN speed index 0 and DIN speed index 2 are invalid, the drive will run at 500rpm in speed mode.

4.3 Torque mode (4)

In torque mode (4 mode), the driver will control the output torque of the motor set by the user during operation.

Table 4-7 torque mode related parameters

Internal address	Type	Name	Description	Value
6060008	Integer8	Operation_mode	Select the working mode according to the actual control mode. 4 is the torque mode	4
60710010	Integer16	Target_Torque%	Target torque, percentage of rated torque	User define
60400010	Unsigned16	Controlword	Enable driver	0x0F

4.3.1 Analog torque mode

In the analog torque mode, the torque of the motor controlled by the driver during operation is determined by the analog voltage input from the outside.

The analog torque object window in the PC software can be accessed via menu item **Controller->Control Modes->Analog Torque Mode**.

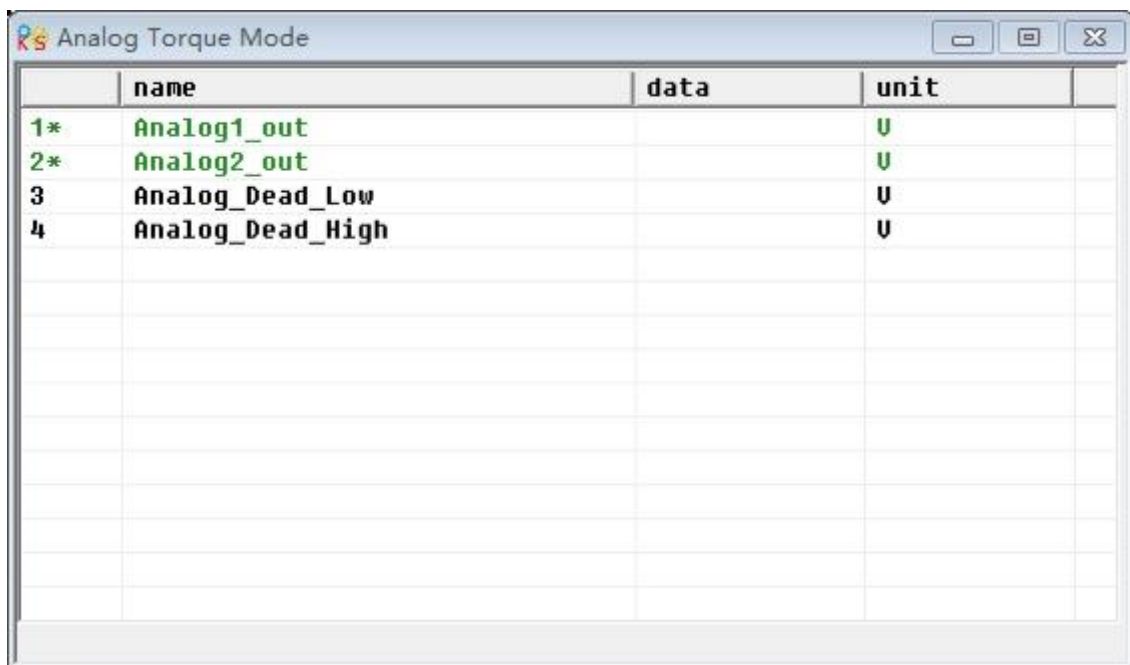


Figure 4-6 "Simulated Torque Mode" window

Table 4-8 simulated torque modes

Internal address	Type	Name	Description	Value
25010610	Unsigned16	ADC1_Buff[1]	AIN1 real input voltage	Read
25020F10	Integer16	Analog1_out	AIN1 valid input, analog input signal1 (AIN1), input voltage after filter, deadband and offset	
25010710	Unsigned16	ADC2_Buff[1]	AIN2 input real data	
25021010	Integer16	Analog2_out	AIN2 valid input, analog input signal2 (AIN2), input voltage after filter, deadband and offset	

25020110	Unsigned16	Analog1_Filter	AIN1 filter (unit: ms)	User defined
25020210	Integer16	Analog1_Dead_V	AIN1 deadband (unit: 0.01V)	
25020310	Integer16	Analog1_Offset_V	AIN1 offset (unit: 0.01V)	
25020410	Unsigned16	Analog2_Filter	AIN2 filter (unit: ms)	
25020510	Integer16	Analog2_Dead_V	AIN2 deadband (unit: 0.01V)	
25020610	Integer16	Analog2_Offset_V	AIN2 offset(unit: 0.01V)	
25020B10	Unsigned16	Voltage_Torque_Factor	AIN-Torque factor (unit: mNm/V)	
25020808	Unsigned 8	Analog_Torque_Con	0: Analog_Torque_control OFF, target torque is specified by Target_Torque% (6071.00) 1: Torque control via AIN1 2: Torque control via AIN2	1 or 2
25020C10	Unsigned16	Voltage_MaxT_Factor	AIN-MaxTorque factor (unit: mNm/V)	User define 0, 1, 2
25020908	Unsigned 8	Analog_MaxT_Con	0: Analog_MaxTorque control OFF 1: max. torque control via AIN1; 2: max. torque control via AIN2	
60F60310	Unsigned16	Speed_Limit_Factor	Influence max speed limit 0x60800010, if value is bigger, limit is better, but if it is too big, it will cause noise	10
60800010	Unsigned16	Max_Speed rpm	Limit motor max speed	

Note

Analog_MaxT_Con is not only used in operation mode 4. All operation modes can use analog output to limit max torque output.

For convenience, some new names are used in the formula. The definitions are as follows:

AIN1_in: AIN1 input voltage after filter and offset.

AIN2_in: AIN2 input voltage after filter and offset.

Analog_out: Analog1_out or Analog2_out, depends on wiring and Analog_Torque_Con setting.

It' s the result of AIN real input, filter, offset and deadband.

Final Result:

When Analog_Torque control is ON, target

torque[Nm]=Analog_out[V]*Analog_Torque_Factor[Nm/V].

When Analog_MaxTorque control is ON, max.

torque[Nm]=Analog_out[V]*Analog_MaxT_Factor[Nm/V].

4.4 Position mode (1)

In the position mode (1 mode), the driver control motor can be positioned in two ways: absolute position positioning and relative position positioning, and the speed and position instructions are controlled by the target position and ladder speed inside the driver.

Table 4-9 location mode parameters

Internal address	Type	Name	Description	Value
60600008	Integer8	Operation_Mode	Way of control motor	1
607A0020	Integer32	Target_Position	Target absolute / relative position	User defined
60810020	Unsigned32	Profile_Speed	Profile speed for positioning	User defined
60400010	Unsigned16	Controlword	Switch from 0x2F to 0x3F: Absolute position; Switch from 0x4F to 0x5F: Relative position 0x103F:Immediate absolute positioning instruction based on target position change	0x2F->0x3F or 0x4F->0x5F

4.4.1 DIN position mode

First, when using the DIN position mode, at least one of the DIN position index 0, DIN position index 1, and DIN position index 2 must be defined in the I/O configuration as a switch signal for the position segment.

DIN position section can be opened through the **driver** -> **control mode** > **DIN position mode** in the upper computer software menu bar.

Table 4-10 DIN position mode introduction

Internal address	Type	Name	Description	Value
2020.01	20	Din_pos[0]	The speed instruction of the drive is specified by DIN speed [x], where x is a BCD code consisting of the following signals: 位 0: Din_pos[0] ; 位 1: Din_pos[1] ; 位 2: Din_pos[2] ; The case where the digits are all 0 cannot occur;	User defined
2020.02	20	Din_pos[1]		
2020.03	20	Din_pos[2]		
2020.04	20	Din_pos[3]		
2020.10	20	Din_pos[4]		
2020.11	20	Din_pos[5]		

2020.12	20	Din_pos[6]	
2020.13	20	Din_pos[7]	
2FF1.01	8	Din_position_selectL	Select the position segment L to be set (L range is 0-7, corresponding to the internal position segment 0-7 in turn)
2FF1.02	10	Din_position_M	Number of pulses set in position segment (L) =M*10000+N
2FF1.03	10	Din_position_n	

For example :

The configuration interface of I/O is shown in the following figure :



Figure 4-7 DIN configuration interface

Table 4-11 Relative Settings for DIN Position Mode

Internal address	Type	Name	Value	Unit
2020.0E	Integer32	Operation mode choose 1	1	
2020.02	Integer32	Din Position [1]	User define	DEC
202006	Integer32	Din Speed [1]	User define	rpm
60830020	Integer32	Profile_ acceleration	User define	rps/s
60840020	Integer32	Profile_ deceleration	User define	rps/s

After enabling, select the location segment to go, the simulation instruction is activated, and the driver executes the selected location segment program.

4.5 Pulse mode (-4)

In the pulse mode, the target velocity command is specified via the pulse input with gear ratio.

Table 4-12 pulse mode related parameters

Internal address	Type	Name	Description	Value
60600008	Integer8	Operation_Mode	Operation mode	-4
25080110	Integer16	Gear_Factor[0]	Gear_ratio=Gear_Factor/Gear_Divider	User define
25080210	Unsigned16	Gear_Divider[0]		
60400010	Unsigned16	Controlword	Enable driver	0x2F:
25080308	Unsigned 8	PD_CW	Pulse train mode 0: CW / CCW 1: Pulse / direction 2: A / B (incremental encoder)	0, 1, 2
25080610	Unsigned16	PD_Filter	Pulse filter (ms)	User define
25080810	Unsigned16	Frequency_Check	Frequency limit (inc/ms), if pulse count (in 1 ms) is greater than Frequency_Check, over frequency error occurs.	

Table 4-13 Pulse Input Supported by Driver

Pulse mode	Forward	Reverse
P/D		
CW/CCW		
A/B		



Note

Forward means positive position counting' s defaulted to the CCW direction. You can set Invert_Dir(607E.00) to 1 in order to invert the direction of motor shaft rotation.

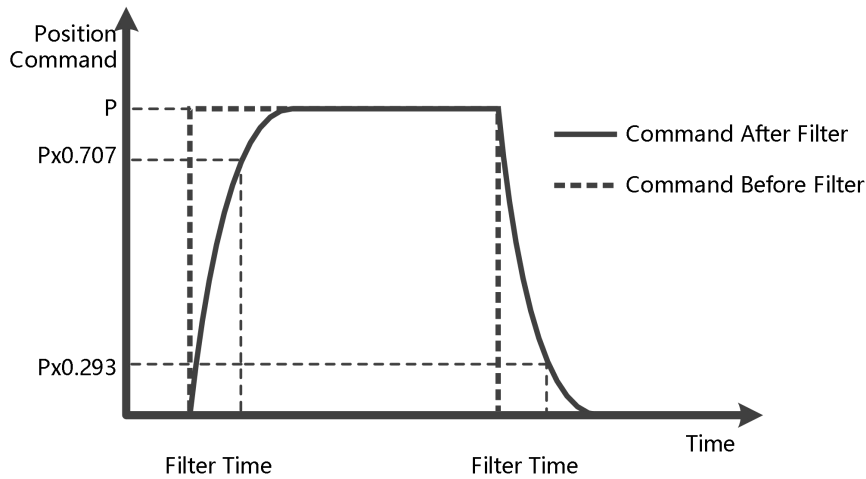


Fig. 4-8 Illustration of Pulse Filtering

4.6 Homing mode (6)

In some applications, the system requires the mechanical load to start from the same position every time it moves, so the user can satisfy this requirement by using the origin pattern. In the origin mode, the user can define an origin or zero to ensure that the mechanical load runs from the same origin each time. The operation interface of origin mode can be opened by the **Menu -> Driver >Control modes ->Homing definition** entry. The operation interface after opening is shown as follow:

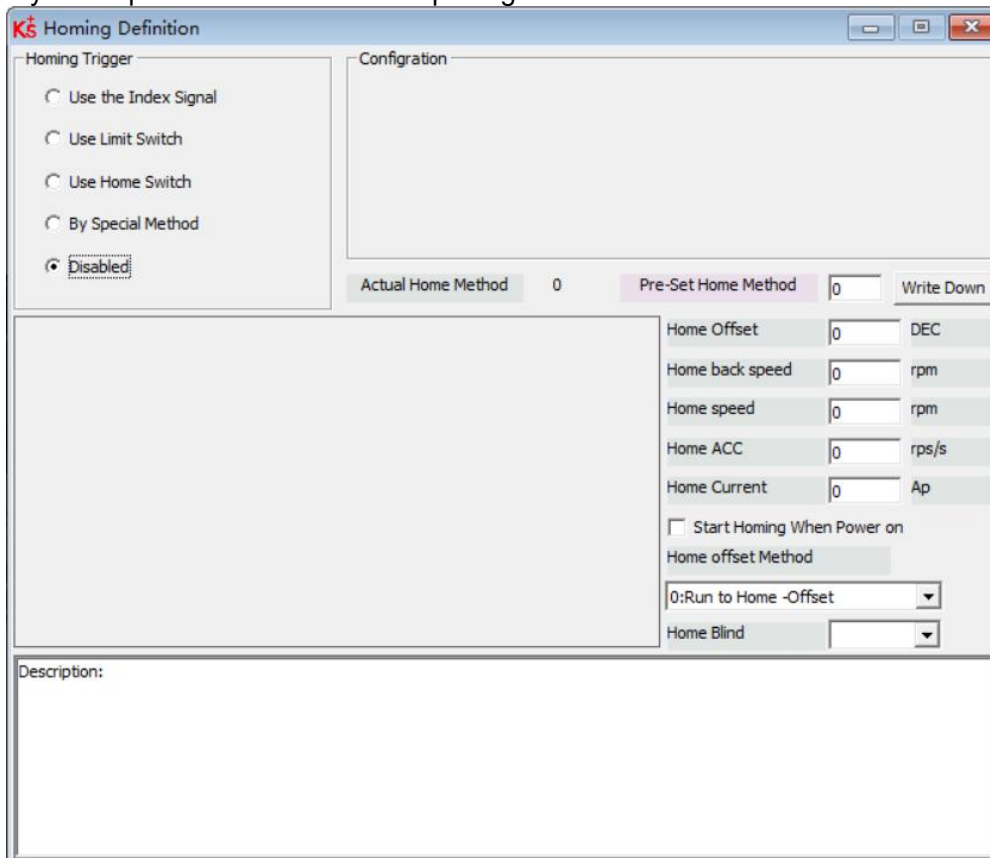
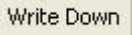


Figure 4-9 Interface of origin definition

Select a home trigger under **Homing Trigger**. The related items appear in the **configuration** area. Select a suitable item according to mechanical design and wiring. The Appropriate homing_method then appears in the **Pre-Set Home Method** box. If **Disabled** is selected under homing trigger, you enter a number directly to the **Pre-Set Home Method** field. Click  to set it to the controller.

The corresponding diagram of the Pre-Set Home method appears in the middle area.

Table 4-14 Description of origin mode parameters

Internal address	Name	Type	Value	Description
607C0020	Home_Offset	Integer32	User define	Zero position offset to the home position
60980008	Homing_Method	Integer 8	User define	Way of homing method
60990220	Homing_Speed_Zero	Unsigned20	User define	Velocity for finding home position and zero position
60990308	Homing_Power_On	Unsigned 8	0, 1	1: Start homing after power on or reboot and first controller enable
609A0020	Homing_Accelaration	Unsigned32	User define	Profile deceleration and acceleration during homing
60990120	Homing_Speed_Switch	Unsigned32	User define	Velocity for searching position limit switch / home switch signal
60990410	Homing_Current	Integer16	User define	Max. current during homing
60990508	Home_Offset_Mode	Unsigned 8	0, 1	0: Go to the homing offset point. The actual position will be 0. 1: Go to the home trigger point. The actual position will be -homing offset.
60990608	Home_N_Blind	Unsigned 8	0, 1	home index signal blind area
60600008	Operation_Mode	Integer8	6	Operation mode
60400010	Controlword	Unsigned16	0x0F->0x1F	Enable driver

Home_N_Blind:

If the homing_method needs home signal (position limit / home switch) and index signal, Home_N_Blind function can avoid the homing result being different with the same mechanics, when the Index signal is very close to the home signal. By setting to 1 before homing, the controller detects a suitable blind window for homing automatically. It can be used to assure that homing results are always the same.

During homing, the index signal inside this blind window is ignored after the home signal is found. Home_N_Blind (0:0rev;1:0.25rev;2:0.5rev) is defaulted to 0. If it's set to 1, it's changed to 0 or 2 after homing depending on the index signal position relative to the homing signal. This parameter needs to be saved. If the mechanical assembly is changed or the motor has been replaced, just set it to 1 again for initial homing.



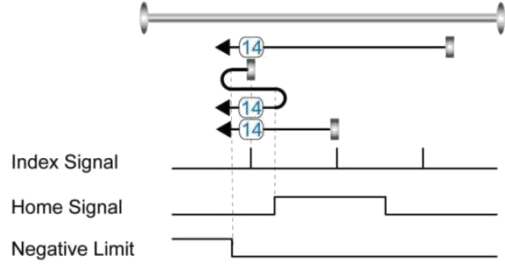
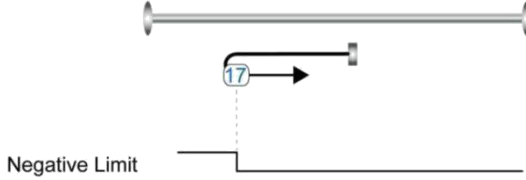
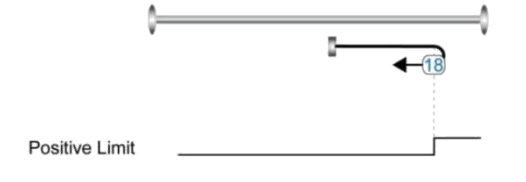
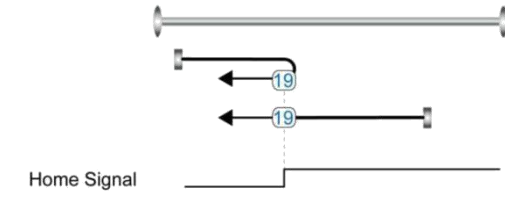
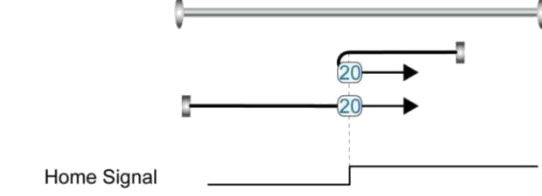
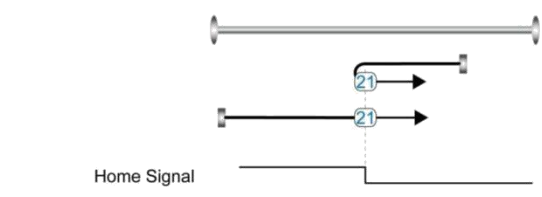
Note

Homing_Power_On=1 causes the motor to start rotating as soon as the controller is enabled after power on or reboot. Consider all safety issues before using.

Table 4-15 Introduction of various origin modes

Homing_ Method	Description	Schematic
1	Homing with negative position limit switch and index pulse	
2	Homing with positive position limit switch and index pulse	
3	Homing with home switch and index pulse	
4	Homing with home switch and index pulse	
5	Homing with home switch and index pulse	
6	Homing with home switch and index pulse	
7	Homing with positive position limit switch, home switch and index pulse	

8	Homing with positive position limit switch, home switch and index pulse	<p>Index Signal</p> <p>Home Signal</p> <p>Positive Limit</p>
9	Homing with positive position limit switch, home switch and index pulse	<p>Index Signal</p> <p>Home Signal</p> <p>Positive Limit</p>
10	Homing with positive position limit switch, home switch and index pulse	<p>Index Signal</p> <p>Home Signal</p> <p>Positive Limit</p>
11	Homing with negative position limit switch, home switch and index pulse	<p>Index Signal</p> <p>Home Signal</p> <p>Negative Limit</p>
12	Homing with negative position limit switch, home switch and index pulse	<p>Index Signal</p> <p>Home Signal</p> <p>Negative Limit</p>
13	Homing with negative position limit switch, home switch and index pulse	<p>Index Signal</p> <p>Home Signal</p> <p>Negative Limit</p>

<p>14</p>	<p>Homing with negative position limit switch, home switch and index pulse</p>	 <p>Index Signal</p> <p>Home Signal</p> <p>Negative Limit</p>
<p>17</p>	<p>Homing with negative position limit switch</p>	 <p>Negative Limit</p>
<p>18</p>	<p>Homing with positive position limit switch</p>	 <p>Positive Limit</p>
<p>19</p>	<p>Homing with home switch</p>	 <p>Home Signal</p>
<p>20</p>	<p>Homing with home switch</p>	 <p>Home Signal</p>
<p>21</p>	<p>Homing with home switch</p>	 <p>Home Signal</p>

<p>22</p>	<p>Homing with home switch</p>	
<p>23</p>	<p>Homing with positive position limit switch and home switch</p>	
<p>24</p>	<p>Homing with positive position limit switch and home switch</p>	
<p>25</p>	<p>Homing with positive position limit switch and home switch</p>	
<p>26</p>	<p>Homing with positive position limit switch and home switch</p>	
<p>27</p>	<p>Homing with negative position limit switch and home switch</p>	
<p>28</p>	<p>Homing with negative position limit switch and home switch</p>	

<p>29</p>	<p>Homing with negative position limit switch and home switch</p>	
<p>30</p>	<p>Homing with negative position limit switch and home switch</p>	
<p>33, 34</p>	<p>Homing with index pulse</p>	
<p>35</p>	<p>Homing to actual position</p>	
<p>-17, -18</p>	<p>Homing via mechanical limit</p>	

Chapter 5 Performance Adjustment

Fig. 5-1 is the control structure diagram of the servo system. It can be seen from the diagram that the servo system generally includes three control loops: current loop, velocity loop and position loop. For the servo system, good control loop parameters can improve the service performance of the servo, can better meet the field process requirements. Therefore, it is necessary to adjust good control loop parameters.

The parameters of speed loop and position loop should be adjusted during debugging. The speed loop parameters are related to the load inertia of the entire mechanical system converted to the motor shaft. The position loop is the outermost control loop of the servo system, which is related to the motor action mode, i.e. field application. The current loop is the innermost control loop in the servo system, and its parameters are related to the motor parameters. After the correct configuration of the motor, the system will default current loop parameters as the best parameters of the equipped motor, so there is no need to adjust again.

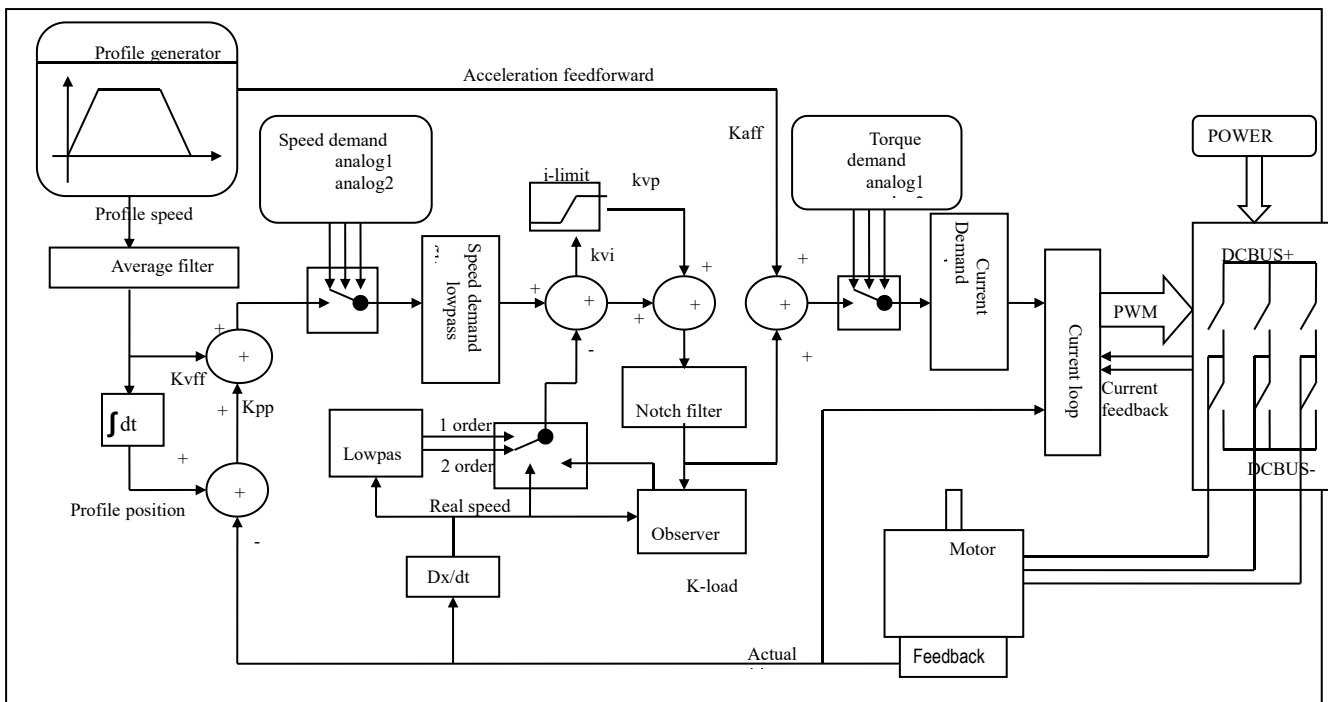


Fig. 5-1 servo system control structure block diagram



- kaf: Position loop acceleration is fed forward
- kvp: Velocity loop proportional gain
- kvi: Velocity loop integral gain
- kpp: Proportional gain of position loop

5.1 Tuning of velocity loop

Table 5-1 List of speed loop parameters

Internal address	Name	Description	Default	Range
60F90110	Kvp[0]	Proportional velocity loop gain Can be displayed in Hz in the PC tool can if the inertia ratio is right.	/	1~32767
60F90210	Kvi[0]	Integral velocity loop gain	/	0-1023
60F90710	Kvi/32	Integral velocity loop gain of in a smaller unit of measure	/	0-32767
60F90508	Speed_Fb_N	Used to set Velocity feedback filter bandwidth Filter bandwidth=100+Speed_Fb_N*20	7	0~45
60F90608	Speed_Mode	Used to set the velocity feedback mode 0: 2nd order FB LPF 1: Directly feedback the original velocity 2: Velocity feedback after velocity observer 4: Velocity feedback after 1st order LPF 10: Velocity feedback after 2nd order LPF and the velocity command is filtered by a 1st order LPF. Both filters have the same bandwidth. 11: The velocity command is filtered by a 1st order LPF 12: Velocity feedback after velocity observer, the velocity command is filtered by a 1st order LPF 14: Velocity feedback after 1st order LPF and the velocity command is filtered by a 1st order LPF. Both filters have the same bandwidth	1	/
60F91508	Output_Filter_N	A 1st order lowpass filter in the forward path of the velocity loop	1	1-127
60F90820	Kvi_Sum_Limit	Integral output limit of the velocity loop	/	0-2 ¹⁵

Step of Velocity loop tuning is shown below:

Velocity feedback filter adjustment

The velocity feedback filter can reduce noise that comes from the feedback path, e.g. reduce encoder resolution noise.

The velocity feedback filter can be configured as 1st and 2nd order via the Speed_Mode for different applications.

The 1st order filter reduces noise to a lesser extent, but its also results in less phase shifting so that velocity loop gain can be set higher. The 2nd order filter reduces noise to a greater extent, but its also results in more phase shifting so that velocity loop gain can be limited.

Normally, if the machine is stiff and light, we can use the 1st feedback filter or disable the feedback filter. If the machine is soft and heavy, we can use the 2nd order filter.

If there' s too much motor noise when velocity loop gain is adjusted, velocity loop feedback filter parameter Speed_Fb_N can be reduced accordingly. However, velocity loop feedback filter bandwidth F must be more than twice as large as the velocity loop bandwidth. Otherwise, it may

cause oscillation. Velocity loop feedback filter bandwidth $F = \text{Speed_Fb_N} * 20 + 100$ [Hz].

Output filter adjustment

The output filter is a 1st order torque filter. It can reduce the velocity control loop to output high frequency torque, which may stimulate overall system resonance.

The user can try to adjust Output_Filter_N from small to large in order to reduce noise.

The filter bandwidth can be calculated using the following formula.

$$\frac{1}{2} \frac{\ln\left(1 - \frac{1}{\text{Output_Filter_N}}\right)}{Ts \pi}, Ts = 62.5 \mu s$$

Velocity loop bandwidth calculation

Use the following formula to calculate velocity loop bandwidth:

$$kvp = \frac{1.853358080 \cdot 10^5 \cdot J \cdot \pi^2 \cdot Fbw}{I_{Max} \cdot kt \cdot encoder}$$

kt motor torque constant, unit: Nm/Arms*100

J inertia, unit: kg*m²*10⁶

Fbw Velocity loop bandwidth, unit: Hz

I_{max} max motor current I_{max}(6510.03) as DEC value

encoder resolution of the encoder

Integral gain adjustment

Integral gain is used to eliminate static error. It can boost velocity loop low frequency gain, and increased integral gain can reduce low frequency disturbance response.

Normally, if the machine has considerable friction, integral gain (kvi) should be set to a higher value.

If the entire system needs to respond quickly, integral should be set to a small value or even 0, and the gain switch should be used.

Adjust Kvi_sum_limit

Normally the default value is fine. This parameter should be added if the application system has a big extend force, or should be reduced if the output current is easily saturation and the saturation output current will cause some low frequency oscillation.

5.2 Tuning of position loop

Table 5-2 List of position loop parameters

Internal address	Name	Description	Default	Range
60FB0110	Kpp[0]	Proportional position loop gain. Used to set the position loop response. unit: 0.01Hz	10	0 ~ 32767
60FB0210	K_Velocity_FF	0 means no feedforward, 1000 means 100% feedforward.	100	0 ~ 100
60FB0310	K_Acc_FF	The unit only is right if the inertia ratio is correctly set. If the inertia ratio is unknown, set K_Acc_FF(60FB.03) instead.	/	0-32767
60FB0510	Pos_Filter_N	The time constant of the position demand LPFunit: ms	1	1~255
60650020	Max_Following_ Error_16	Maximum allowable error, Max_Following_Error (6065.00) = 100 * Max_Following_Error_16	10000	/

Step of Position loop tuning is shown below:

Position loop proportional gain adjustment

Increasing position loop proportional gain can improve position loop bandwidth, thus reducing positioning time and following error, but setting it too high will cause noise or even oscillation. It must be set according to load conditions. $K_{pp} = 103 * P_{c_Loop_BW}$, $P_{c_Loop_BW}$ is position loop bandwidth. Position loop bandwidth cannot exceed velocity loop bandwidth. Recommended velocity loop bandwidth: $P_{c_Loop_BW} < V_{c_Loop_BW} / 4$, $V_{c_Loop_BW}$.

Position loop velocity feedforward adjustment

Increasing the position loop velocity feedforward can reduce position following error, but can result in increased overshooting. If the position command signal is not smooth, reducing position loop velocity feedforward can reduce motor oscillation.

The velocity feedforward function can be treated as the upper controller (e.g. PLC) have a chance to directly control the velocity in a position operation mode. In fact this function will expend part of the velocity loop response ability, so if the setting can't match the position loop proportional gain and the velocity loop bandwidth, the overshoot will happen.

Besides, the velocity which feedforward to the velocity loop may be not smooth, and with some noise signal inside, so big velocity feedforward value will also amplified the noise.

Position loop acceleration feedforward

It is not recommended that the user adjust this parameter. If very high position loop gain is required, acceleration feedforward K_{Acc_FF} can be adjusted appropriately to improve

performance.

The acceleration feedforward function can be treated as the upper controller (e.g. PLC) have a chance to directly control the torque in a position operation mode. In fact this function will expend part of the current loop response ability, so if the setting can't match the position loop proportional gain and the velocity loop bandwidth, the overshoot will happen.

Besides, the acceleration which feedforward to the current loop can be not smooth, and with some noise signal inside, so big acceleration feedforward value will also amplified the noise.

Acceleration feedforward can be calculated with the following formula:

$$\text{ACC}_{\%} = 6746518 / K_{\text{Acc_FF}} / \text{EASY_KLOAD} * 100$$

ACC_%: the percentage which will be used for acceleration feedforward.

K_Acc_FF(60FB.03): the final internal factor for calculating feedforward.

EASY_KLOAD(3040.07): the load factor which is calculated from auto-tuning or the right inertia ratio input.



Note

The smaller the K_Acc_FF, the stronger the acceleration feedforward.

Smoothing filter

The smoothing filter is a moving average filter. It filters the velocity command coming from the velocity generator and makes the velocity and position commands more smooth. As a consequence, the velocity command will be delayed in the controller. So for some applications like CNC, it's better not to use this filter and to accomplish smoothing with the CNC controller.

The smoothing filter can reduce machine impact by smoothing the command. The Pos_Filter_N parameter defines the time constant of this filter in ms. Normally, if the machine system oscillates when it starts and stops, a larger Pos_Filter_N is suggested.

Notch filter

The notch filter can suppress resonance by reducing gain around the resonant frequency.

$$\text{Antiresonant frequency} = \text{Notch_N} * 10 + 100$$

Setting Notch_On to 1 turns on the notch filter. If the resonant frequency is unknown, the user can set the maximum value of the d2.14 current command small, so that the amplitude of system oscillation lies within an acceptable range, and then try to adjust Notch_N and observe whether the resonance disappears.

Resonant frequency can be measured roughly according to the Iq curve when resonance occurs on the software oscilloscope.

Table 5-3 List of notch filter parameters

Internal address	Name	Description	Default	Range
60F90308	Notch_N	Used to set the frequency of the internal notch filter to eliminate mechanical resonance generated when the motor drives the machine. The formula is $F = \text{Notch_N} * 10 + 100$. For example, if mechanical resonance frequency $F = 500$ Hz, the parameter setting should be 40.	45	0~90
60F90408	Notch_On	Used to turn on or turn off the notch filter. 0: Turn on the notch filter 1: Turn off the notch filter	0	0~1

5.3 Factors which influence tuning results

The control command is created by the upper controller (e.g. PLC):

The control command should be smooth as much as possible, and must be correct. For example, the control command should not create the acceleration commands (inside the position commands) that the motor cannot provide. Also, the control command should follow the bandwidth limit of the control loop.

The machine design:

In the actual application, performance is normally limited by the machine. Gaps in the gears, soft connection in the belts, friction in the rail, resonance in the system – all of these can influence final control performance. Control performance affects the machine's final performance, as well as precision, responsiveness and stability. However, final machine performance is not only determined by control performance.

Chapter 6 Alarms and troubleshooting

When driver generate an alarm, red light, ERR, will shine.

If you need more detailed information about errors and error history, please connect the controller to the PC via RS232.

Table 6-1 Error status word 1 alarm code

Alarm	Code	Name	Reason	Troubleshooting
000.1		Extended Error	Errors occurs in Error_State2	Press the SET key to enter Error_State2 (d1.16), read the error bit, check the error meaning in table 7-2.
000.2	0x7380	Encoder ABZ signal incorrect (suitable for incremental encoder motor)	Encoder ABZ wiring is wrong or disconnected	1. Check whether the original cable model is correct, and check whether the pins at both ends of the encoder cable are properly connected by referring to the selection manual. Use shielded twisted pair cables for non-original cables 2. Check that the motor encoder terminal is firmly connected and the driver encoder terminal is pressed tightly 3. Replace the new encoder cable and compare the motor test
	0x7331	Encoder communication incorrect (suitable for magnetoelectric encoder motor)	The encoder wiring is incorrect or disconnected.	
000.4	0x7381	Encoder UVW signal incorrect (suitable for incremental encoder motor)	Encoder UVW wiring is wrong or disconnected	It usually appears with 000.2. Check the encoder cable as described above
	0x7320	Encoder internal (suitable for magnetoelectric encoder motor)	Encoder internal is incorrect or encoder is broken	Check whether the motor model is set correctly Check that the encoder cable is properly connected
000.8	0x7305	Encoder count wrong (suitable for incremental encoder motor)	Encoder is interfered	1. Check encoder cable is correctly connected (different from motor PE cable) 2. Make sure the equipment is well grounded 3. Use isolated power supply to provide power
	0x7330	Encoder CRC (suitable for magnetoelectric encoder motor)		1. Check whether the motor model is set correctly 2. Check whether the encoder line is broken, and the encoder line should be separated from the power line 3. Replace new encoder wire and motor comparison test
001.0	0x4210	Controller temperature	The temperature of controller's power module has reached the alarm value	Add fan, improve the cooling environment of the controller. Add driver installment distance Vertically install driver
002.0	0x3210	Overvoltage	Supply power voltage exceeds the allowable input voltage range	Check if supply power is higher than standard output voltage Check to see if supply power voltage is unstable

			In case of emergency stop, there is no external braking resistor or braking.	Connect suitable braking resistor Open software "Driver"->"Panel menu"->" (F005) controller setting" Correctly set "brake resistor value" an "brake resistor power"
			Brake resistor is not configured	Change Connect suitable braking resistor Open software "Driver"->"Panel menu"->" (F005) controller setting" Correctly set "brake resistor value" an "brake resistor power"
004.0	0x3220	Undervoltage	The power voltage input is lower than the low voltage protection alarm value.	Check if power supply output power can meet with the requirement Change power supply of bigger power
008.0	0x2320	Short circuit of driver output	Short circuit of driver UVW and PE output	Check if motor power cable connection is correct Driver is broken, change driver
	0x2321		The ADC current reaches saturation	Check the motor model is set correctly
010.0	0x7110	Driver brake resistor is abnormal	Not configure correct brake resistor parameters	Open software "Driver"->"Panel menu"->" (F005) controller setting" Correctly set "brake resistor value" an "brake resistor power"
020.0	0x8611	Following error	Stiffness of control loop is too small	1.Open software "Driver""->control loop""->velocity loop"and"position loop" 2.Increase "kpp[0]""kvp[0]"
			The maximum motor speed limit is too small	Open the menu bar of the upper computer software "Drive" -> "Control Panel" -> "Control Ring Settings" to check the setting value of "Maximum Speed Limit rpm"
			The controller and motor together can't match the requirement of the application	Change motor and driver with bigger power
			Max_Following_Error is too small	1.Open software "Driver""control loop""velocity loop""position loop" 2.Increase "max_following_error" (Ensure control loop parameters is fine, user can change this parameter)
			The target current limit is too small	Open the menu bar of the upper computer software "Drive" -> "Basic Operation" to check the setting value of "Target Current Limit"
040.0	0x5122	Low logic voltage	Logic voltage is less than 18V, power supply voltage is pulled down	1.Check if power supply output power can meet with requirements 2.Change power supply with bigger power
080.0	0x2350	Motor or controller IIt	The brake is not released when the motor shaft is rotating (only for brake motor)	1.Check if brake cable wiring is correct 2.Check brake power can meet with the requirements (output voltage is DC24V, input current is 1A, output power is bigger than 24W)
			Machine equipment stuck or excessive friction	1.Cancel motor enable, or power off driver 2.Please drag load to make it move back and forth in motor's running route. Ensure that there is no machine equipment stuck or excessive friction 3.Add lubricate
			Motor UVW phase sequence is incorrect	Connect motor cable using the correct phase sequence

			The controller and motor together can't match the requirement of the application	Change motor and driver with bigger power
100.0	0x8A80	Over input frequency	External input pulse frequency is too high	1.Reduce external pulse input frequency 2.When ensure safely use motor, increase "Frequency_Check" (Open"Driver"->"Control modes"->"Pulse mode"->"Frequency_Check") , max 600
200.0	0x4310	Motor temperature	The motor temperature exceeds the specified value	1.Reduce ambient temperature of the motor and improve cooling conditions 2.Reduce acceleration and deceleration
400.0	0x7122	Motor excitation (suitable for incremental encoder)	Motor UVW phase sequence is wrong	Exchange motor wiring of phase U and phase V
			Encoder is not connected	Check encoder cable
	0x7331	Encoder information (suitable for magnetoelectric encoder)	Communication is incorrect when the encoder is initialized	1. Usually appears with 000.2, indicating that the communication encoder communication error, open the upper computer software menu bar "motor" -> 2. Check whether the cable model is correct. By referring to the selection manual, check whether the pins at both ends of the encoder cable are properly connected. 3. Check that the motor encoder terminal is firmly connected and the driver encoder terminal is pressed tightly 4. Replace the new encoder cable and compare the motor test
			The encoder type is wrong, e.g. an unknown encoder is connected	
The data stored in the encoder is wrong				
The controller can't support the current encoder type				
800.0	0x6310	EEPROM data	Data is damaged when the power is turned on and data is read from the EEPROM	1.Open software"Driver"->"Init Save Reboot" 2.Click"Init Control Parameters"->"Save Control Parameters"->"Save Motor Parameters"->"Reboot" 3.Import cdi file by software 4.Check whether the logical power supply voltage is stable

Table 6-2 error status word 2 alarm code

Alarm	Code	Name	Reason	Trouble shooting
000.1	0x5210	Current sensor	Current sensor signal offset or ripple too big	Circuit of current sensor is damaged, please contact the supplier
000.2	0x6010	Watchdog	Software watchdog exception	Please contact the supplier and try to update the firmware
000.4	0x6011	Wrong interrupt	Invalid interrupt exception	Please contact the supplier and try to update the firmware
000.8	0x7400	MCU ID	Wrong MCU type detected	Please contact the supplier
001.0	0x6320	Motor configuration	Motor type is not auto-recognized, no motor data in EEPROM / motor never configured	Install a correct motor type to the controller and reboot

010.0	0x5443	External enable	DIN function “pre_enable” is configured, but the input is inactive when the controller is enabled or should become enabled	Solve according to the reason
020.0	0x5442	Positive limit	Positive position limit (after homing), position limit only causes error when Limit_Function (2010.19) is set to 0	Exclude the condition which causes the limit signal
040.0	0x5441	Negative limit	Positive position limit (after homing), position limit only causes error when Limit_Function (2010.19) is set to 0	Exclude the condition which causes the limit signal
080.0	0x6012	SPI internal	Internal firmware error in SPI handling	Please contact the supplier
200.0	0x8A81	Close loop direction	Different direction between motor and position encoder	Change the encoder counting direction
800.0	0x7306	Master counting	Master encoder counting error	Ensure that the ground connection and the encoder shield work well.

Appendix 1 Control terminal wire making instructions

OD series with the product distribution of each port of the plug terminals and pins, need to cooperate with the use of wire and DuPont terminal pressure pliers as the cable.

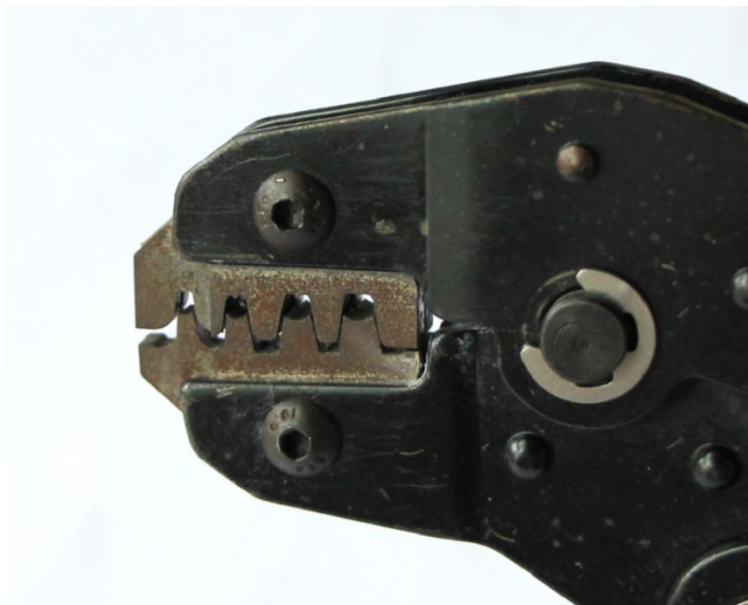
Stamping steps:

Step 1: Prepare the wire pressing tool, DuPont terminal wire pressing pliers, recommended brand: Taiwan Baogong, model: CP-384N.

Step 2: first open the presser and insert the presser terminal into the presser. The terminal is aligned with the left edge of the pliers, and the right side shows a section as shown in the figure below.



Step 3: peel the wire harness off the insulation layer, close up and sort it out, and plug it into the terminal from the left side of the pliers. Make sure the wire is in place and press the handle of the wire clamp on the clamping terminal.



Step 4: the following figure is the pressure connection terminal, it can be inserted into the corresponding terminal plug.

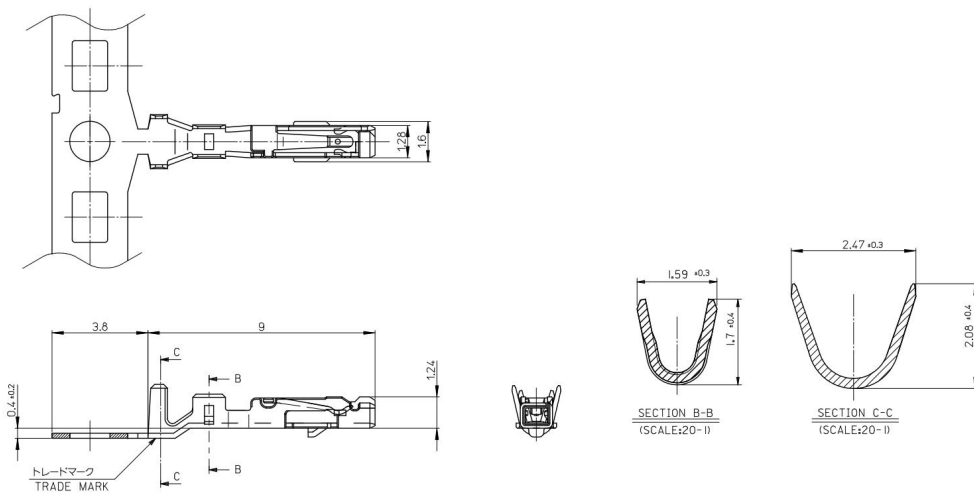


Fig. 1 X1 and X2 interface metal pins specification

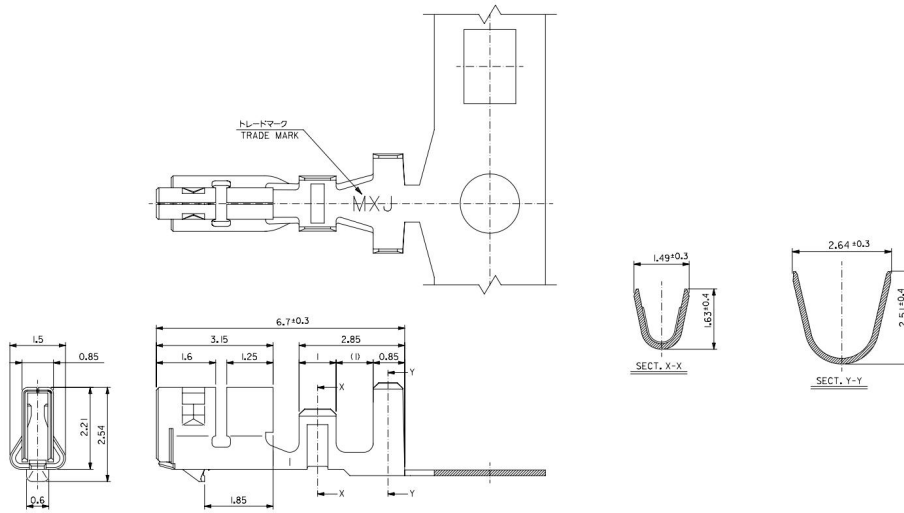


Figure 2 X3 bus communication interface metal pin specifications

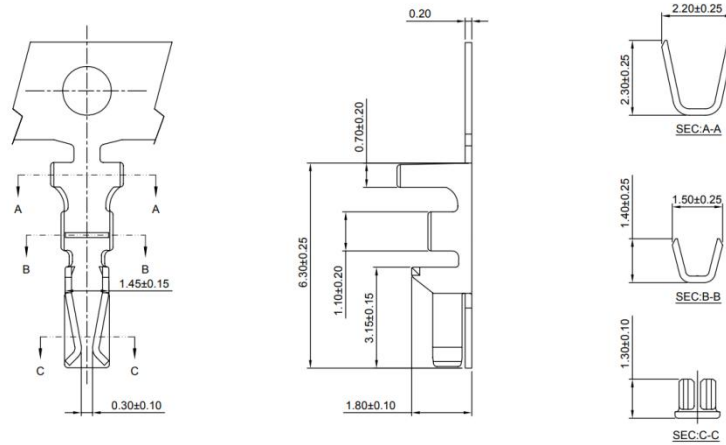


Fig. 3 Specification of metal pins for X4RS232 communication interface

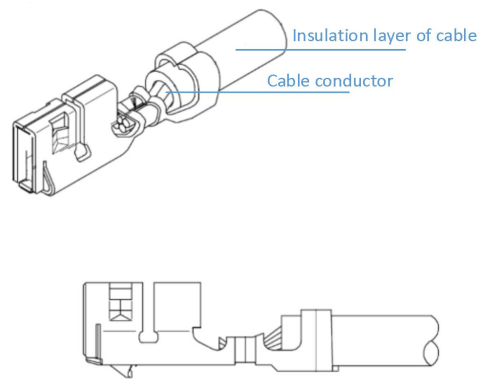


Fig. 4 Schematic diagram of needle pressing



Note

- Refer to Table 3-2 for external wiring methods in Section 3-2 for cable specifications