



iSMK integrated servo and FD1X5 drive User manual

Preface

Thank you for using Kinco servo products! iSMK and FD1X5 servo driver are a new generation of small size, good performance and high stability products developed by Kinco after market research and according to the characteristics of the automation industry. They support CAN, Modbus control methods, widely used in logistics storage equipment, mobile handling equipment, sorting cars, mobile service robots and other fields. For customers who have special requirements in communication mode, installation mode, protection level, etc., we also provide customized servo drives and motors for various application scenarios.

Please read the manual carefully and follow the operation requirements in the manual, which will help you correctly set up the drive to achieve the best performance.

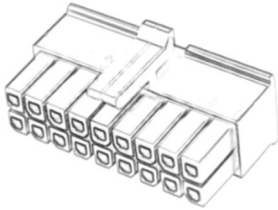
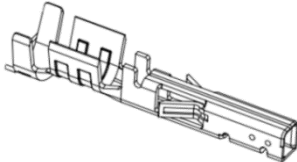
Confirmation

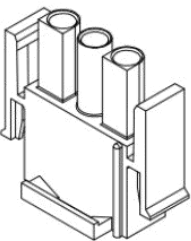
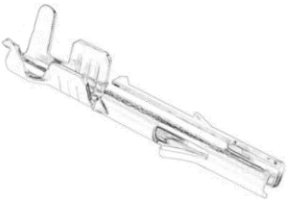

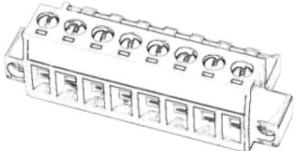

- Please confirm whether the product is damaged during transportation
- Please confirm the motor model, drive model, and motor wiring model are consistent with the model you ordered according to the nameplate information on the drive and motor.
- Please confirm whether the terminal accessories of the drive is complete, and the motor oil seal and keys are complete on the drive.

If there is any problem with any of the above, please contact Kinco or your supplier to solve it.

Parts list

Driver accessories package

Accessory package	Name	External view	Model	Count	Note
iSMK accessory package	Housing		MOLEX 430251800	1	
	Contact pin		MOLEX 430300004	20	

	Power line housing		C6350HF-3P-V0	1	<p>This connector is not universal, if you need to purchase, please visit the connector website for details. Official website Address: https://www.hr-connector.com.tw/</p>
	Power line terminal		C6350F-TBe	3	
FD125 accessory package	Double row 2*7 terminal		F7G-3.5-14P-A	1	
	Terminal head		F6AM-5.08-08P-1-A	1	
FD135,FD145 accessory package	Double row 2*7 terminal		F7G-3.5-14P-A	1	

Motor accessories package

Motor	Part size
iSMK60	Framework oil seal (15*25*4)
	Plain C flat key (GB/T 1096 key C 5*5*16)
iSMK80	Framework oil seal (20*30*4)
	Plain C flat key (GB/T 1096 key C 6*6*25)
SMK60	Framework oil seal (15*21*3)
	Plain C flat key (GB/T 1096 key C 5*5*16)
SMK80	Framework oil seal (20*30*4)
	Plain C flat key (GB/T 1096 key C 6*6*25)

Cable accessories package

Accessory package	Name	Model	Count	Note
ENCHG-GA	Encoder connector	SUNCHU SC-MC7S-A820-P0	1	ENCHG-GA is suitable for both ENCHG-LL-GA and ENCHGF-LL-GA
	Encoder terminal	SANCHU FMC19012220	5	
MOT/MOTF-005-KA	Power connector	SUNCHU SC-MC6S-AE20-00	1	MOT/ MTF-005-KA is suitable for the MOT-005-LL-KA-D MOTF-005-LL-KA-D
	Power terminal	SANCHU FMCK6012220	6	
	Ziplock bag	130×190×0.05	1	
	Silver Label (PET Light)	20×35 double row (5000pcs/ volume)	1	
MOT-011-KA	Power connector	SUNCHU SC-MC6S-AQ20-00	1	The MOT-011-KA is suitable for MOT-005-LL-KAB-D MOTF-005-LL-KAB-D MOT-011-LL-KA-D MOTF-011-LL-KA-D MOT-011-LL-KAB-D MOTF-011-LL-KAB-D
	Power terminal	SANCHU FMC25012220	4	
	Wiring terminal	SANCHU FMC19012220	2	
MOT-KA(OD<11mm)	Power connector	JinLing6353E-06S-AB-W01	1	Mot-KA (OD<11mm) is suitable for MOT/ MTF-020-LL-KA-D
	Power terminal	JinLing202.6353E0103P02	5	
	Brake terminal	JinLing202.6353E0103P01	3	
MOT-KA(OD≥11mm)	Power connector shell	JinLing6353E-06S-AB-W00	1	MOT-KA(OD≥11mm) is suitable for MOT/MOTF-020-LL-KAB-D MOT/MOTF-030-LL-KA-D MOT/MOTF-030-LL-KAB-D
	Power terminal	JinLing202.6353E0103P02	5	
	Brake terminal	JinLing202.6353E0103P01	3	

Safety attentions

Security Definition

The following safety symbols are used in the safety-related contents of this manual. Please observe them to avoid injury.



Danger

Wrong operation could lead death or serious injury.



Warning

Risk of minor injury or serious property damage.



Note

Information marked for attention helps ensure proper product operation.



Remind

Suggestion, reminding, or reference linking

Security Claims

● **Operating qualifications**

This product must be operated by trained professionals. In addition, the operator must go through professional skills training, familiar with the installation, wiring, operation and maintenance of the equipment, and correctly respond to various emergency situations in use.

● **Unpacking and Acceptance**



Note

- Before unpacking, first check whether the appearance of the package is normal and intact, without obvious scratches, extrusion deformation, damage, or be affected with damp. For safety reasons, do not use products with damaged packaging or parts.
- Please verify that the model number and quantity match the order information as per the order list inside the box and the nameplate information on the product.
- Please confirm whether all terminal accessories are complete and there are no defects or rust on the surface of the product.

● **Storage and Transportation**



Warning

- When handling, please handle with care. Do not stack the products too high to prevent product damage and personal injury caused by product fall.
- If the drive is not used for a long time, it should be confirmed whether there is water or dew inside the product before use, otherwise there is the risk of burning the drive. Please carry out closer protection and necessary inspection.
- If the driver is placed in a low temperature environment for a long time, place it at a temperature higher than 0 °C for a period of time before use to avoid damage to the driver.
- Please store the product in accordance with the specifications and avoid shock and vibration of the driver during transportation and storage, otherwise it will cause the risk of product damage.



Remind

- If the drive is not intended to be used for a long time, it is recommended that the drive be powered on every few months to prevent damage to internal components due to moisture. At the same time, the drive should be more tightly protected storage and pre-use inspection.
- When the product needs to be transported over long distances, it is necessary to pack the product into a closed box before it can be transported.

● Installation and operation



Warning

- Install in a place that can support the weight of the drive, otherwise there is a risk of injury or damage to property when dropped.
- Ensure that the driver is securely installed and screws are tightened. Pay attention to sharp edges and corners of the driver to avoid injuries or cuts caused by falling.
- The product should be installed in a place that is not easy to burn, to prevent the invasion of dust, corrosive gases, conductive objects, liquids and flammable substances, and to maintain good heat dissipation conditions;
- Ensure that all protective measures are activated before powering on the product.
- Do not touch the shell, brake resistance and other parts to test the temperature during the operation of the product, otherwise there is the risk of burning.
- In the application of dust, metal debris, oil pollution serious, should use a good sealing equipment electrical cabinet.
- The static electricity on the human body may seriously damage the sensitive components inside. Before performing related operations, observe the measures and methods specified in ESD. Otherwise, the drive may be damaged.
- It is forbidden to modify the drive without permission. If the drive is damaged due to private modification, the Department will not be responsible for it!



Danger

- If the surface of the product is damaged or the parts are incomplete, do not install and operate, otherwise there is a risk of fire and injury.
- Foreign objects such as screws, metal gaskets, and metal rods falling into the drive pose a fire hazard and property damage.
- Wiring operations must be carried out by qualified personnel, otherwise there is a risk of electric shock.
- Ensure the input power is completely disconnected before wiring ,otherwise, electric shock may occur.
- The ground terminal of the driver must be grounded reliably; otherwise, electric shock may occur.
- RB+ and RB- terminals are used to connect brake resistors. Do not short circuit them, otherwise they may cause damage or fire.
- This product controls a potentially dangerous movement. Failure to comply with the regulations or perform operations in accordance with the requirements of this manual may result in personal injury, injury, and damage to the product and associated systems.

- Before powering on the device, ensure that the power supply meets requirements. Otherwise, the device may be damaged or a fire may occur.
- When energized, do not touch the product and terminal, do not disassemble the parts of the product, otherwise there is the risk of electric shock.
- Maintenance operations should be performed 10 minutes after the power is disconnected; otherwise, there is a risk of electric shock.
- Only professional personnel can replace the parts, it is strictly prohibited to leave the wire or metal in the machine, otherwise there is the risk of fire.



Remind

- Please use the cables specified by our company whenever possible when wiring. If the cable is not specified by the kinco, please purchase the specified wiring material or equivalent after confirming the rated current or use environment of the model used.
- Do not lay or bind encoder cables and signal cables in the same casing. Too close a distance will cause signal interference and cause motor misoperation.

Manual version revision records

Date	Update content
2024-4	First edition
2024-7	<ul style="list-style-type: none"> ● Add the contents of the cable accessories package ● 3.2.4.1 delete the introduction to pin 8 of X1,update isolator purchase link ● Add content about CANopen communication connect to the host computer ● 5.6.5 Supplementary information ● Add 7.15 chapter ● The original 8.4, 8.5 chapters were changed to 8.3.1, 8.3.2 sections ● Add 8.4 RS232 communication protocol related content ● Modified the remarks about phase inductance and phase resistance in Appendix 1 ● Add iSMK40 related content ● 3.5 Add iSMK overload characteristic curve
2024-8	<ul style="list-style-type: none"> ● 4.1.2 Modified the host computer communication connection content ● 5.6 Add pulse function description ● 4.2.2, 5.7.5 Update content
2024-9	<ul style="list-style-type: none"> ● Add iSMK-EA related content ● 1.2.1.3 Modified the iSMK40 TN Curve ● Add FD1X5 drive screw tightening torque
2024-11	<ul style="list-style-type: none"> ● 3.3 Add fuse recommended specification ● Add FD1X5-EB content

Content

Preface.....	1
Confirmation.....	1
Parts list.....	1
Safety attentions.....	3
Manual version revision records.....	7
Chapter 1 System configuration and product description.....	1
1.1 Product description.....	1
1.1.1 iSMK series product description.....	1
1.1.1.1 iSMK series naming rule.....	1
1.1.1.2 iSMK configuration Description.....	1
1.1.2 FD1X5 series product description.....	2
1.1.2.1 Drive naming rule.....	2
1.1.2.2 Motor naming rule.....	2
1.1.2.3 Connecting cable naming rule.....	3
1.1.2.4 Motor configuration description.....	4
1.2 Product parameters.....	4
1.2.1 iSMK series product parameters.....	4
1.2.1.1 Electric parameter.....	4
1.2.1.2 Use environment parameter.....	5
1.2.1.3 TN curve instruction.....	6
1.2.2 FD1X5 series product parameters.....	8
1.2.2.1 Driver electrical parameter.....	8
1.2.2.2 Driver use environment parameter.....	8
1.2.2.3 Motor specification parameter description.....	9
1.3 Product characteristic.....	13
1.3.1 Derating characteristic.....	13
Chapter 2 System Installation requirements and announcement.....	14
2.1 Servo system use requirements.....	14
2.1.1 Transport and storage conditions.....	14
2.1.2 Technical requirements.....	14

2.1.3 Operator requirements	14
2.1.4 Announcement	15
2.1.5 Oil seal installation instructions	16
2.2 Servo system mounting dimensions	17
2.2.1 iSMK series mechanical dimensions	17
2.2.2 FD1X5 series mechanical dimension	20
2.2.3 Motor mechanical dimensions	22
2.3 Driver installation spacing and auxiliary heat dissipation	23
2.3.1 FD1X5 series driver installation spacing	23
2.3.1.1 Auxiliary heat dissipation description	24
2.3.2 iSMK Series installation spacing	25
2.3.2.1 iSMK auxiliary heat dissipation description	25
Chapter 3 System interface and wiring	27
3.1 iSMK series system interface and wiring	27
3.1.1 Part name	27
3.1.2 External wiring diagram	28
3.1.3 Cable model and terminal description	28
3.1.4 Electrical wiring	31
3.2 FD1X5 series system interface and wiring	33
3.2.1 Part name	33
3.2.2 External wiring diagram	34
3.2.2.1 Brake resistance selection	34
3.2.3 Cable Description	35
3.2.4 Driver Interface Terminal Description	41
3.2.4.1 Bus Communication Interface (X1)	41
3.2.4.2 Communication Debugging Interface (X2)	41
3.2.4.3 Digital Signal Input/Output Interface (X3)	42
3.2.4.4 Encoder Interface (X4)	42
3.2.4.5 Power and Motor Ports (X5)	42
3.2.5 Driver electrical wiring	44
3.2.6 Brake connection	45
3.2.6.1 Internal brake connection	45
3.3 External installation instructions	46
3.4 EMC Configuration Description	47
3.5 Servo overload protection feature	50

3.6 Power Supply Description	51
Chapter 4 Trial operation	53
4.1 KS3 debugging software description	53
4.1.1 Overview	53
4.1.2 Connection	53
4.1.2.1 Description of the connection between the PC and the drive	53
4.1.2.2 Start KincoServo3	58
4.1.3 Debugging Software Function Description	58
4.2 Pre-operation preparation	59
4.2.1 Cable Connection and environment Check	59
4.2.2 Motor parameter check	59
4.3 Trial operation	60
Chapter 5 Working mode introduction	61
5.1 Server Status	62
5.1.1 Server Status	62
5.1.2 Control word and status word description	63
5.1.2.1 Control word description 604000	64
5.1.2.2 Status Word Description 604100	65
5.2 Speed Mode (-3, 3) description	66
5.2.1 Related Function Settings	67
5.2.1.1 DIN Speed mode introduction	67
5.2.1.2 Speed to function	68
5.2.1.3 Zero speed function	68
5.2.1.4 Maximum speed limit function	68
5.3 Torque mode (4)	69
5.3.1 Related function Settings	69
5.3.1.1 Maximum speed limit function in torque mode	69
5.3.1.2 Torque reaches the preset function	70
5.4 Position mode (1)	70
5.4.1 Related function Settings	71
5.4.1.1 DIN Position mode introduction	71
5.4.1.2 Position-to-function	72
5.4.1.3 Position following error monitoring function	72
5.5 Homing mode (6)	72
5.6 Pulse mode (-4)	81

5.7 Other application control functions	82
5.7.1 Limit function	82
5.7.2 Motor brake control	82
5.7.2.1 Motor brake signal function introduction	84
5.7.3 Stop Mode Control	85
5.7.4 Absolute value system instruction	86
5.7.4.1 Multi-turn motor power-on configuration	86
5.7.4.2 Multi-Circle Data Range	87
5.7.4.3 Multi-turn prohibition	88
5.7.4.4 Battery instruction	88
5.7.5 Motor configuration instructions	88
Chapter 6 Performance adjustment	90
6.1 Online auto-tuning	90
6.2 Manual tuning	91
6.2.1 Speed loop setting method	91
6.2.2 Position loop setting method	96
6.3 Gain switch (Pro mode)	98
6.3.1 Gain switching method	99
6.4 Other factors affecting performance	100
Chapter 7 List of Common Object Parameters	101
Object list	101
7.1 Mode and Control (0x6040)	103
7.2 Metrical data	104
7.3 Target object (0x607A)	104
7.4 Multi-segment position/Multi-segment speed (0x2020)	105
7.5 Performance object (0x6065)	106
7.6 Homing control (0x6098)	107
7.7 Speed loop parameter (0x60F9)	107
7.8 Position loop parameter (0x60FB)	107
7.9 Input/output port parameter (0x2010)	108
7.10 Pulse input parameters (0x2508)	111
7.11 Parameter for storage (0x2FF0)	111
7.12 Error code (0x2601)	112
7.13 Stop mode	112
7.14 Alarm parameter	113

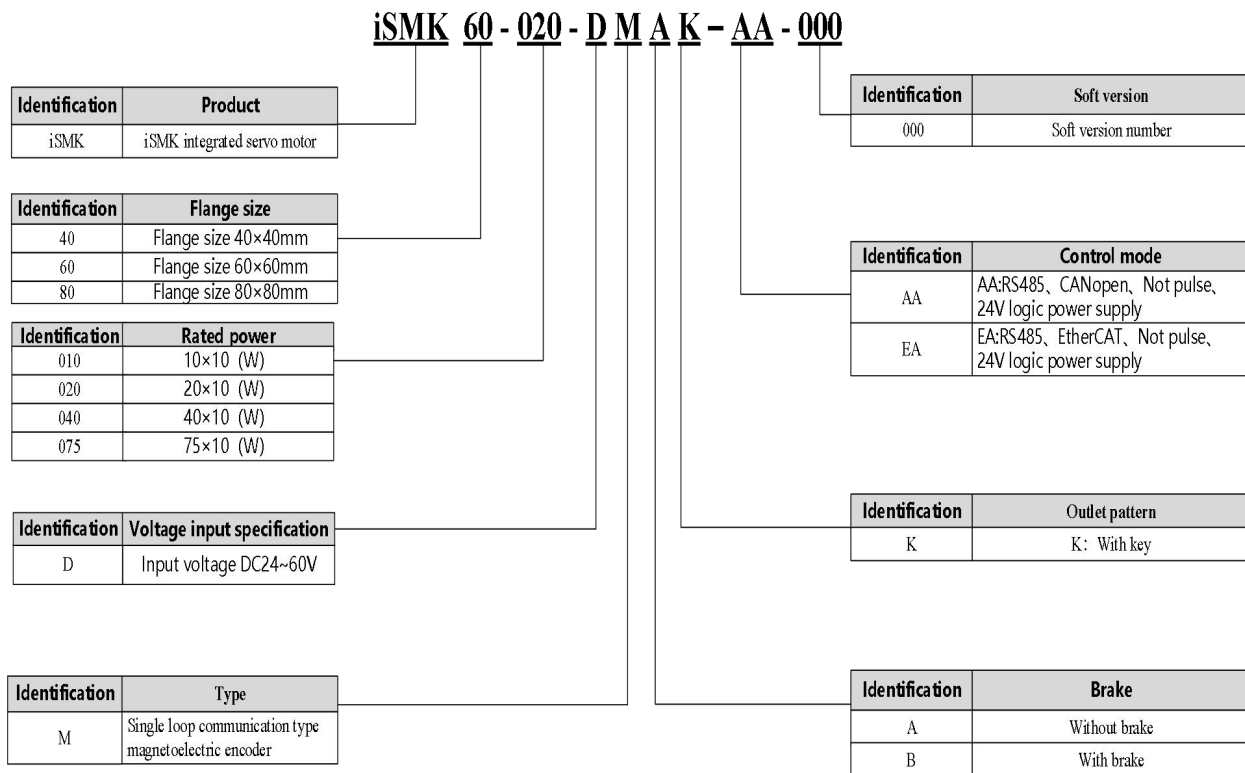
7.15 Other Parameter	114
Chapter 8 RS485 Communication	115
8.1 RS485 cable connection	115
8.2 RS485 communication parameters list	116
8.3 MODBUS RTU protocol	116
8.3.1 Modbus common function codes introduction	116
8.3.2 Modbus packet Example	117
8.4 RS232 communication protocol	120
8.4.1 RS232 transport protocol	120
8.4.2 RS232 data protocol	121
8.5 Troubleshooting Measures for Communication Faults	124
Chapter 9 CANopen Communication	125
9.1 CANopen communication protocol introduction	125
9.2 Hardware Description	125
9.3 Software Description	127
9.3.1 EDS description	127
9.3.2 SDO Description	127
9.3.3 PDO Description	131
9.3.3.1 PDO COB-ID Description	131
9.3.3.2 COB-ID	132
9.3.3.3 PDO transmission type	133
9.3.3.4 Protection Mode/Monitoring Type Description	135
9.3.3.5 Startup process description	137
9.3.3.6 Emergency message description	138
9.4 CANopen Bus Communication Setting	139
9.5 Interpolation mode based on CANopen	140
Chapter 10 Alarm exclusion	142
10.1 Mistakes and historical errors	142
10.2 Alarm cause and treatment measures	144
Appendix I Method of configuring a third-party motor	148
Appendix II Commonly used formulas	149

Chapter 1 System configuration and product description

1.1 Product description

1.1.1 iSMK series product description

1.1.1.1 iSMK series naming rule



1.1.1.2 iSMK configuration Description

Model	Power	Configure cable specification
iSMK40-010-D□■K-▲A-000	100W	See section 3.1.3 for details
iSMK60-020-D□■K-▲A-000	200W	
iSMK60-040-D□■K-▲A-000	400W	
iSMK80-075-D□■K-▲A-000	750W	

Note

- 1: □= M: Single loop communication type magnetoelectric encoder
- 2: ■=A: Without brake
=B: With brake
- 3: ▲=A: RS485、CANopen
=E: RS485、EtherCAT

1.1.2 FD1X5 series product description

1.1.2.1 Drive naming rule

FD 1 2 5 - AB - 000

Identification	Serial number
FD	FD series

Identification	Voltage input specification
1	Input voltage DC24~60V

Identification	Rated output current
2	2: 15Arms
	3: 30Arms
	4: 50Arms
	6: 80Arms

Identification	Drive version
5	The fifth generation version low voltage drive

Identification	Soft version
000	Soft version number

Identification	Control mode
AB	AB:USB, RS485, CANopen, Have pulse, 24V logic power supply
EB	EB:USB, EtherCAT, Have pulse, 24V logic power supply

1.1.2.2 Motor naming rule

SMK 60 S - 0040 - 30 S A K - 5 D S A

Identification	Serial number
SMK	Common ontology series

Identification	Flange
60	60: Flange size 60x60mm
	80: Flange size 80x80mm

Identification	Type
S	Small inertia

Identification	Rated power(W)
0040	0020: 20x10(W)
	0040: 40x10(W)
	0075: 75x10(W)
	0100: 100x10(W)

Identification	Rated speed
30	30x100 (rpm)

Identification	Motor outlet mode
A	Common ontology motor special socket

Identification	Motor version
S	S: S version
K	K: K version

Identification	Voltage level
D	DC48V

Identification	Pole pairs number
5	5 pole pair

Identification	Outlet pattern
K	K: With key

Identification	Brake
B	A: Without brake
	B: With brake

Identification	Encoder type
S	S: Single loop communication type magnetolectric encoder
	Q: Multi-turn communication magnetolectric absolute value encoder

1.1.2.3 Connecting cable naming rule

(1) Power line

MOT F - 005 - LL - KAB - D

Identification	Cable function category
MOT	Motor power cable

Identification	Cable category
F	F: Flexible cable
	Null: Common cable

Identification	Rated current
005	005: 5A
	011: 11A
	020: 20A
	030: 30A

Identification	Connector type
D	DC servo standard connector

Identification	Motor outlet type
KAB	KA: Pluggable motor connector (Power)
	KAB: Pluggable motor connector (Power and brake)

Identification	Cable length
LL	(5):0.5 meter
	01:1 meter
	02:2 meter
	03:3 meter

Note: LL indicates the cable length

(2) Encoder cable

ENC D G F - LL-G A- DC

Identification	Cable function category
ENC	Motor encoder cable

Identification	Driver encoder interface type
D	1394 interface
H	3 rows of 15 pin connectors

Identification	Driver interface definition
G	Communication interface

Identification	Cable category
F	F: Flexible cable
	Null: Common cable

Identification	Cable attachment
DC	Null: Not battery
	DC: With battery (Suitable for multi-turn absolute encoder motor)

Identification	Motor side encoder connector type
A	U: 1394 interface
	A: Plug-in encoder connector

Identification	Cable core number
G	G: 6 core cable

Identification	Cable length
LL	(5): 0.5 meter
	01: 1 meter
	02: 2 meter
	03: 3 meter

Note: LL indicates the cable length

1.1.2.4 Motor configuration description

Motor Type	Power	Power/Brake cable	Encoder cable	Servo driver
				CANopen+RS485
SMK60S-0020-30SAK-5DSA	200W	MOT-005-LL-KA-D	ENCHG-LL-GA	FD125-AB-000
SMK60S-0020-30SBK-5DSA		MOT-005-LL-KAB-D		
SMK60S-0040-30SAK-5DSA	400W	MOT-011-LL-KA-D		
SMK60S-0040-30SBK-5DSA		MOT-011-LL-KAB-D		
SMK80S-0075-30SAK-5DKA	750W	MOT-020-LL-KA-D		FD135-AB-000
SMK80S-0075-30SBK-5DKA		MOT-020-LL-KAB-D		
SMK80S-0100-30SAK-5DKA	1000W	MOT-030-LL-KA-D		
SMK80S-0100-30SBK-5DKA		MOT-030-LL-KAB-D		
SMK60S-0020-30QAK-5DSA	200W	MOT-005-LL-KA-D	ENCDG-LL-GA/ ENCHG- (4) -GU-DC	FD125-AB-000
SMK60S-0020-30QBK-5DSA		MOT-005-LL-KAB-D		
SMK60S-0040-30QAK-5DSA	400W	MOT-011-LL-KA-D		
SMK60S-0040-30QBK-5DSA		MOT-011-LL-KAB-D		
SMK80S-0075-30QAK-5DKA	750W	MOT-020-LL-KA-D		FD135-AB-000
SMK80S-0075-30QBK-5DKA		MOT-020-LL-KAB-D		
SMK80S-0100-30QAK-5DKA	1000W	MOT-030-LL-KA-D		
SMK80S-0100-30QBK-5DKA		MOT-030-LL-KAB-D		

Note:

1. The "LL" in the list of power/brake/encoder cables indicates the cable length, see the model description;
2. ENCHG- (4) -GU-DC is the necessary battery power cable for the multi-turn absolute encoder motor, with a wire length of 40cm
3. SMK80S-0100-30QAK-5DKA is recommended to match FD135, If 3 times overload is required, it needs to be matched with FD145

1.2 Product parameters

1.2.1 iSMK series product parameters

1.2.1.1 Electric parameter

Model parameter		iSMK40-010-D□K-▲A-000	iSMK60-020-D□K-▲A-000	iSMK60-040-D□K-▲A-000	iSMK80-075-D□K-▲A-000
Input	power	24VDC ~ 60VDC			
	Built-in fuse	Null			
	Logic power	24VDC,1A			
Duty		S3-10min-60% (intermittent periodic duty, cycle time 10min, 60% working time) S1 (continuous duty) torque must be derated to 70%			
Rated power P _n (W)		100	200	400	750
Rated speed n _N (rpm)		3000			
Rated torque T _s (Nm)		0.32	0.64	1.27	2.39
Maximum torque T _m (Nm)		0.96	1.92	3.81	7.17
Energy consumption brake		There is no brake circuit inside the driver, and an external brake module is required			
Overvoltage alarm voltage		The default is 70V			
Undervoltage alarm voltage		The default is 18V			
Cooling mode		Natural cooling			
Rotational inertia J _m (Kg·cm ²)		0.044 0.046 (With brake)	0.17 0.176 (With brake)	0.31 0.314 (With brake)	0.85 0.91 (With brake)
Logical loss power (mW)		900			
General function	Input specification	2 channels digital input, COM1 terminal; High level: 12.5 ~ 30VDC Low level: 0 ~ 5VDC Input impedance: 5KΩ Maximum frequency: 1KHz			
	Input function	Freely defined as required, the functions are as follows: drive enable, drive error reset, drive mode control, speed loop proportional control, positive limit, negative limit, origin signal, command reverse, internal speed segment control, internal position segment control, emergency stop, start to find the origin, command activation, electronic gear ratio switching, gain switching			

	Output specification	1 digital output, OUT1 for the open collector output, the highest voltage 30V, driving capacity of 100mA
	Output function	Freely defined according to needs, the functions are as follows: driver ready, driver error, motor position to, motor zero speed, motor lock brake, motor speed to, index Z signal appears, maximum limit speed in torque mode, motor lock shaft, motor limit medium, origin finding
	Protect function	Overvoltage protection, undervoltage protection, motor overheat (I ² T) protection, short circuit protection, drive overheat protection
	Brake	B With brake (Power conversion, external release brake) , A Without brake
Bus function	Modbus/RS485	It supports a maximum 115.2Kbps baud rate and can communicate with the controller using the Modbus RTU
	CANopen	It supports a maximum 1Mbps baud rate and can communicate with the controller using the CANopen
	EtherCAT	Support COE (CiA402 protocol) and CSP/CSV/PP/PV/PT/HM mode, communication speed 100M
EMC		Meet the requirements for standards EN 61800-3

Note 1: □= M: Single loop communication type magnetoelectric encoder
 2: ■ =A: Without brake
 =B: With brake
 3: ▲ =A: RS485、CANopen
 =E: RS485、EtherCAT

Duty type

S3-10min-60% Meaning: iSMK products in S3(intermittent periodic duty) state, a cycle time (10min) can only run under rated load for 6min, the remaining 4min to stop the operation, so cycle operation.

S1 (continuous duty) torque must be derated to 70% Meaning: iSMK products need to reduce the motor torque to 70% of the rated torque in S1 (continuous duty) state.

If used outside the above range, it may cause an alarm 0x0800 (motor or drive IIT), 0x2000 (motor overtemperature), 0x0010 (drive overtemperature).

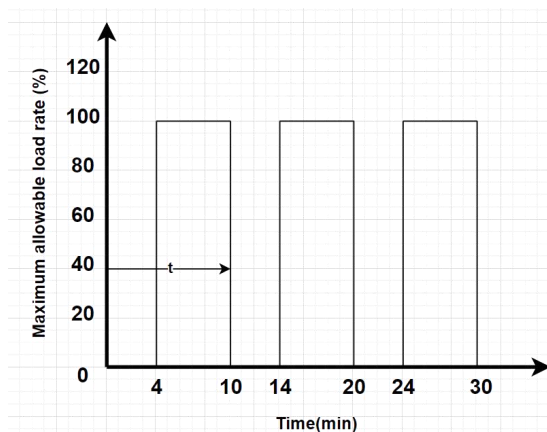


Figure 1-1 S3 duty diagram

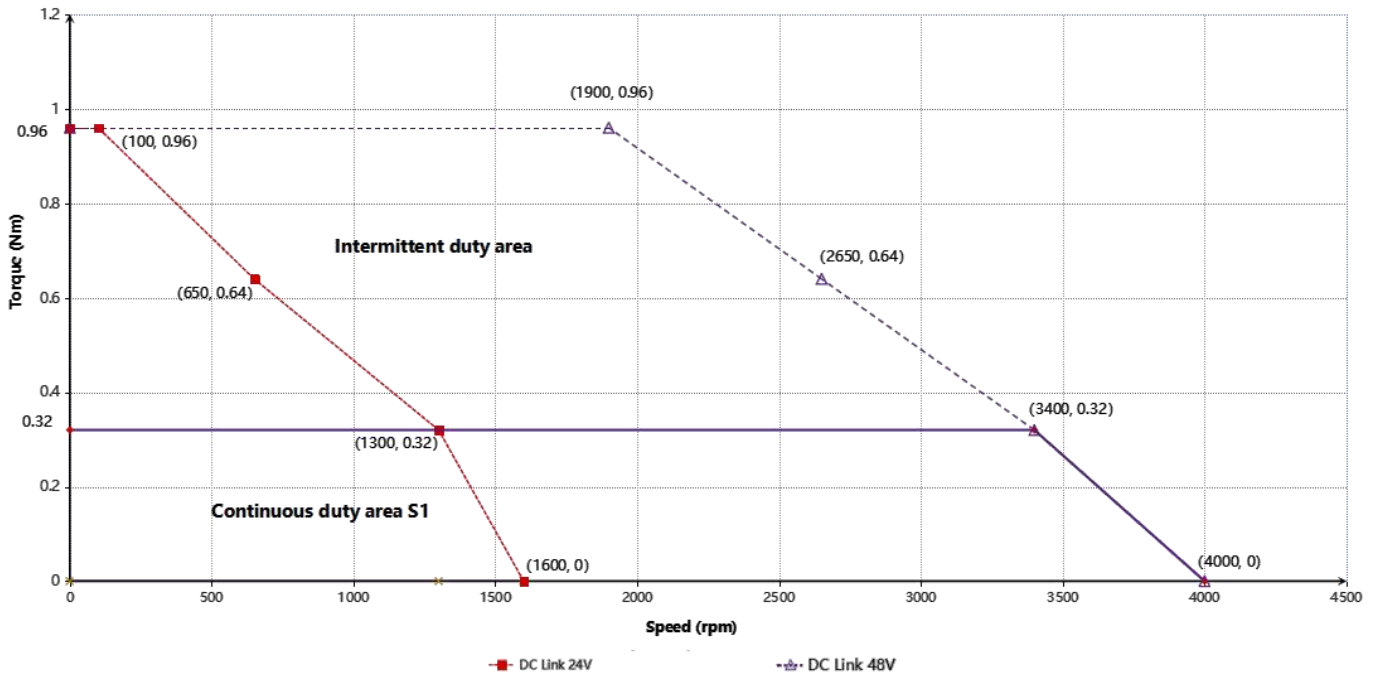
1.2.1.2 Use environment parameter

Working Temperature	-20°C ~ 40°C (no freezing) ,When the operating temperature exceeds 40°C, the driver needs to be derated
Working Humidity	Less than 90%RH (no condensation)
Storage temperature	-40°C ~ 70°C (no freezing)
Storage humidity	90%RH (no condensation)
Protection grade	IP65, shaft end IP54
Altitude	The rated working altitude is less than 1000 meters above sea level. When the working altitude is higher than 1000 meters, it is necessary to reduce the rated value by 1.5% for every 100 meters of elevation. The maximum working altitude is 2000 meters above sea level.
Vibration	Running: 10Hz~57Hz 0.075 mm amplitude 57Hz~150Hz 1g
Atmospheric pressure	86kpa~106kpa
Installation method	Motor flange mounting (vertical side mounting)

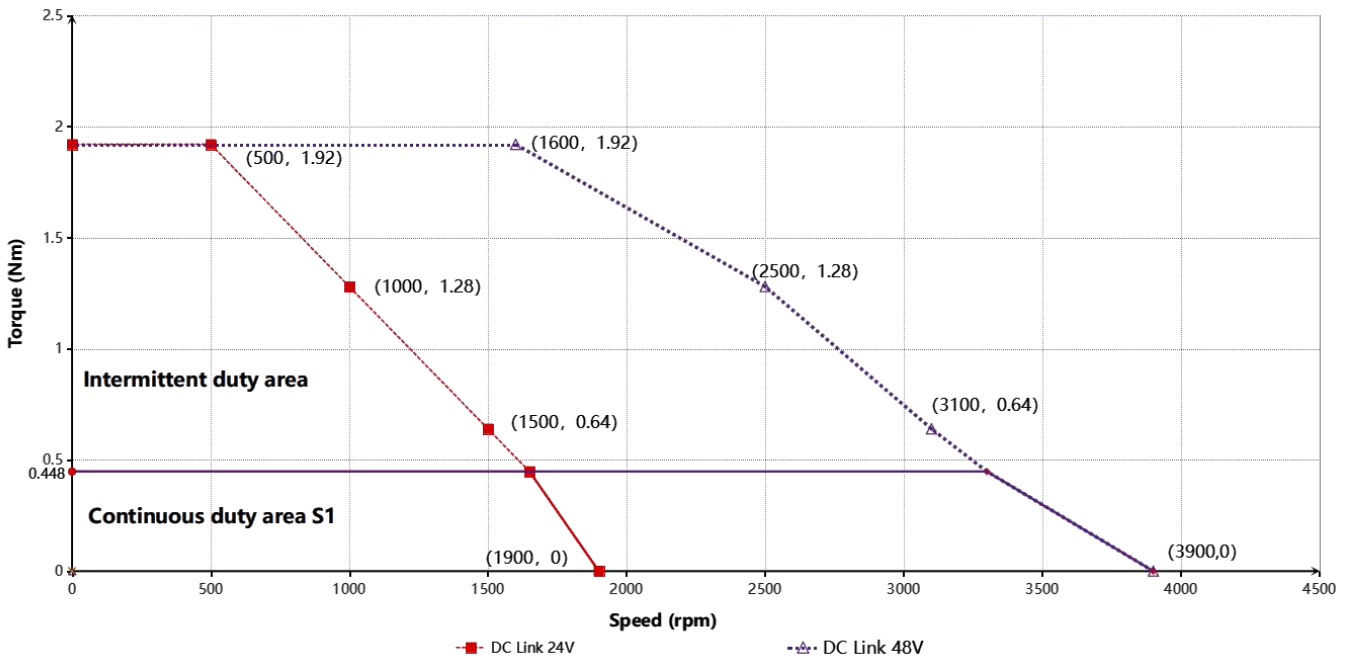
Note: The reduction method used by iSMK in different scenarios is different. If you need to use it in more than 40 degrees, please contact the manufacturer.

1.2.1.3 TN curve instruction

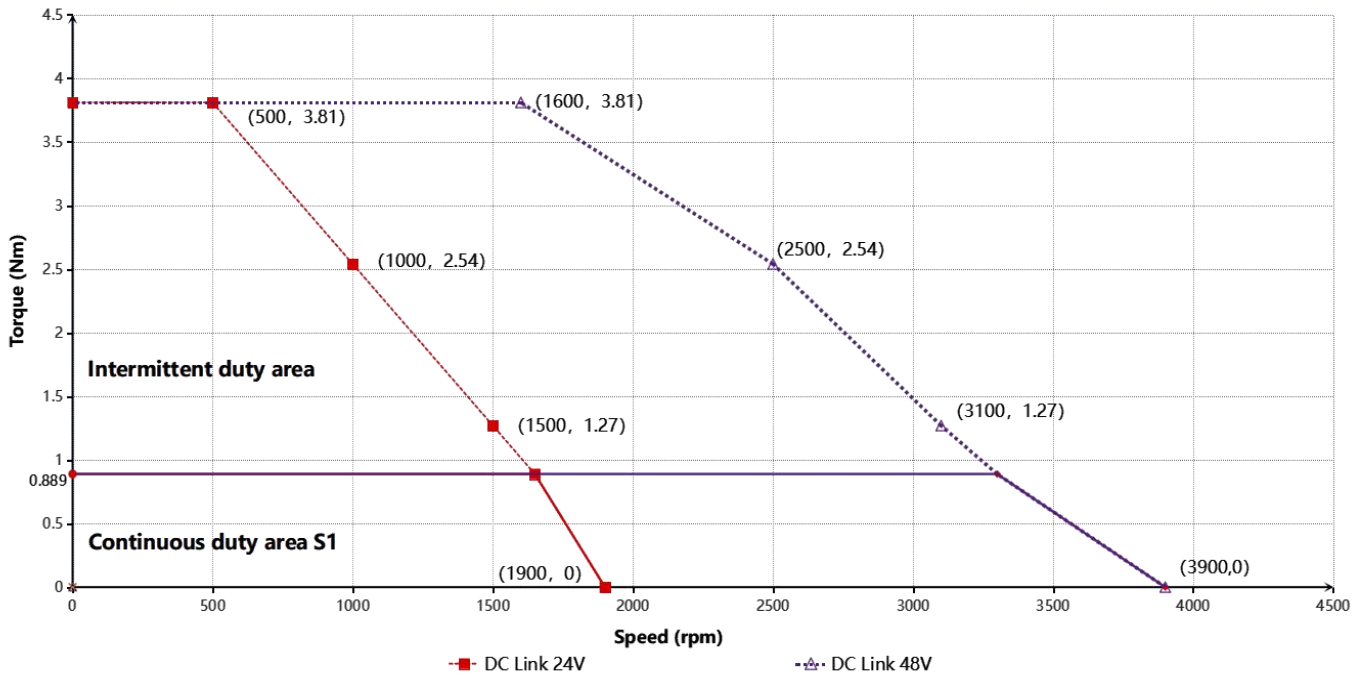
iSMK40-010-DM■K-□A-000



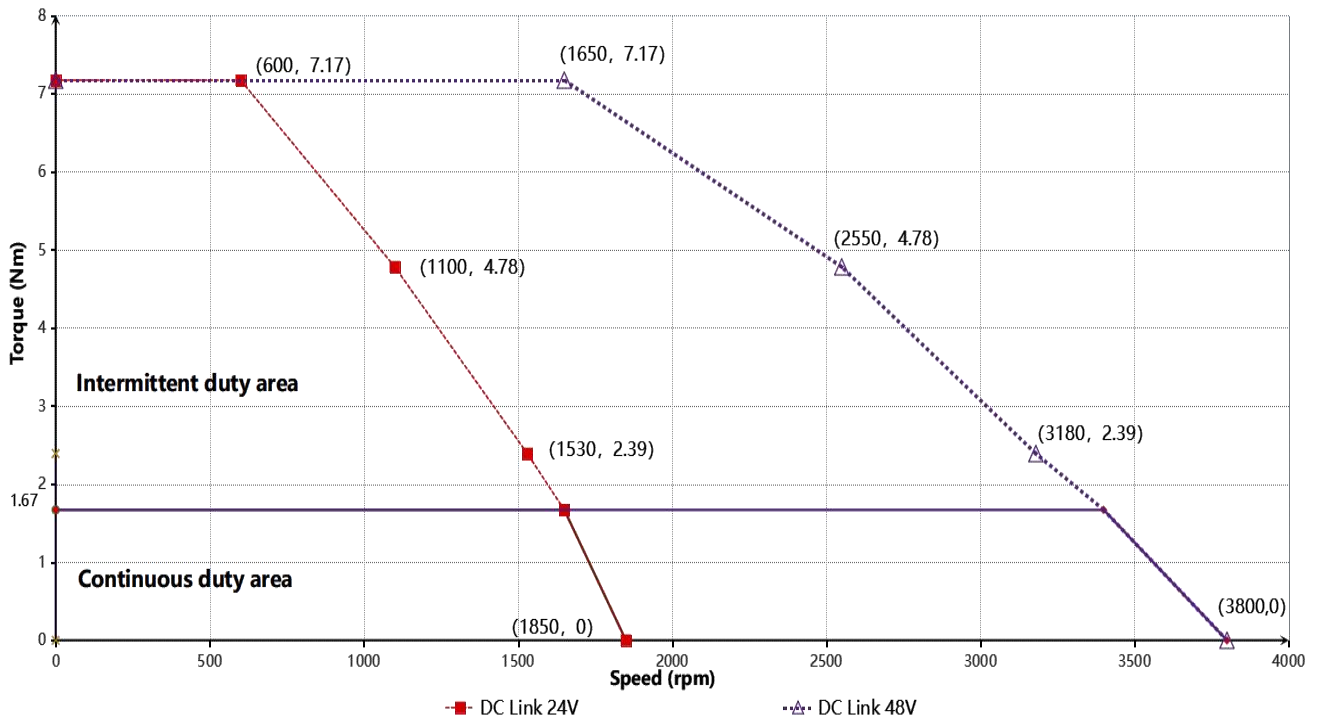
iSMK60-020-DM■K-□A-000



iSMK60-040-DM■K-□A-000



iSMK80-075-DM■K-□A-000



1.2.2 FD1X5 series product parameters

1.2.2.1 Driver electrical parameter

Model parameter		FD125-□B-000	FD135-□B-000	FD145-□B-000
Input voltage	Power	24VDC ~ 60VDC		
	Logic power	24VDC 1A (Optional connection or not)		
Output current	Maximum continuous output current (rms)	15Arms (Up to 12Arms without auxiliary cooling plate)	30Arms (Up to 22Arms without auxiliary cooling plate)	50Arms (Up to 35Arms without auxiliary cooling plate)
	Peak current (AP)	48	100	160
Feedback signal		Tamagawa protocol single-tur/multi-turn encoder		
Energy consumption brake		Need external brake resistance (depending on the operation condition, mainly used in rapid start-stop occasions)		
Energy consumption brake voltage absorption point		The default is 63V		
Overvoltage alarm voltage		The default is 70V		
Undervoltage alarm voltage		The default is 18V		
Cooling mode		Natural cooling		
Weight (KG)		0.322	0.657	0.861
Logic loss power (mW)		1000	1200	1300
General function	Input specification	3 channels digital input, COM1 terminal; High level: 12.5-30VDC; Low level: 0-5VDC; Maximum frequency: 1KHz; Input impedance: 5KΩ.		
	Input function	Freely defined as required, the functions are as follows: drive enable, drive error reset, drive mode control, speed loop proportional control, positive limit, negative limit, origin signal, command reverse, internal speed segment control, internal position segment control, emergency stop, start to find the origin, command activation, electronic gear ratio switching, gain switching		
	Pulse control	Pulse + Direction, A phase + B phase (3.3V~24V)		
	Output specification	1 digital output, OUT1 is an open collector output, up to 30V, 100mA drive capability, The brake is PWM output, the effective voltage value is 24V, (BR+/BR-) capacity is 1A, no external power supply is required, and the brake device can be directly driven		
	Output function	Freely defined according to needs, the functions are as follows: driver ready, driver error, motor position to, motor zero speed, motor lock brake, motor speed to, index Z signal appears, maximum limit speed in torque mode, motor lock shaft, motor limit medium, origin finding		
	Type-C	Debug special, can use Kinco PC software connection		
Bus function	Protect function	Overvoltage protection, undervoltage protection, motor overheat (I ² T) protection, short circuit protection, drive overheat protection		
	Modbus/RS485	It supports a maximum 115.2K baud rate and can communicate with the controller using Modbus RTU		
	CANOpen	It supports a maximum of 1 M baud rate and can communicate with the controller using the CANopen		
EtherCAT		Support COE (CiA402 protocol) and CSP/CSV/PP/PV/PT/HM mode, communication speed 100M		
EMC		Meet the requirements for standards EN 61800-3, EN61000-6-2, EN61000-6-4		
Note : □ =A: RS485、CANopen =E: EtherCAT				

1.2.2.2 Driver use environment parameter

Working Temperature	-20℃ ~ 40℃ (no freezing) .When the operating temperature exceeds 40℃, the driver needs to be derated
Working Humidity	Less than 90%RH (no condensation)
Storage temperature	-40℃ ~ 70℃ (no freezing)
Storage humidity	90%RH (no condensation)
Protection class	IP20
Altitude	The rated working altitude is less than 1000 meters above sea level. When the working altitude is higher than 1000 meters, it is necessary to reduce the rated value by 1.5% for every 100 meters of elevation. The maximum working altitude is 2000 meters above sea level.
Atmospheric pressure	86kpa ~ 106kpa
Installation site	Dust-free, dry, lockable (e.g. electrical cabinet)
Installation method	Install vertically or horizontally

1.2.2.3 Motor specification parameter description

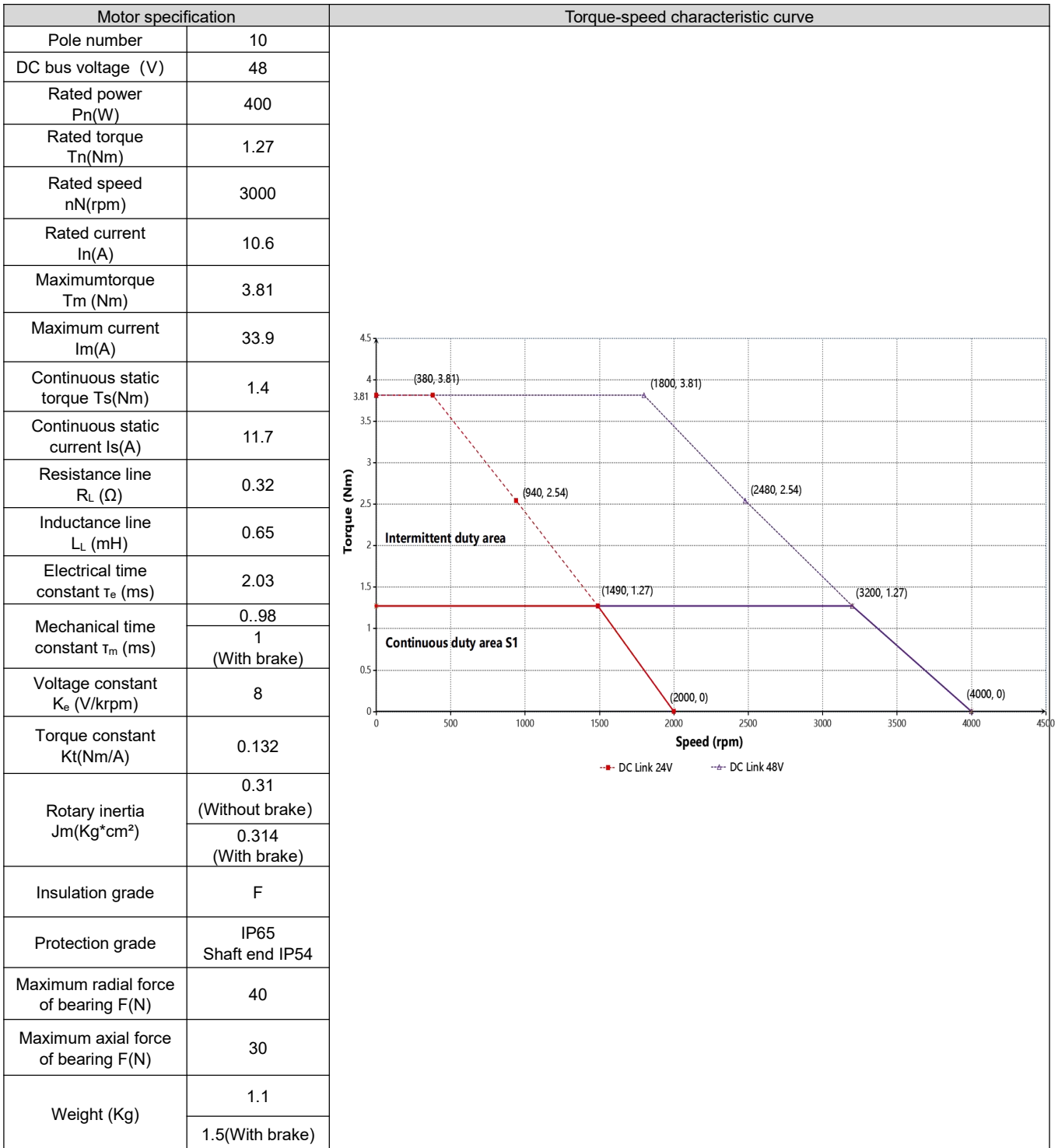
SMK60S-0020-30S■K-5DSA (The black box indicates the motor with or without brake)

Motor specification		Torque-speed characteristic curve	
Pole number	10	<p>The graph plots Torque (Nm) on the y-axis (0 to 2.5) against Speed (rpm) on the x-axis (0 to 5000). Two curves are shown: a red line for DC Link 24V and a purple line for DC Link 48V. Key data points are: (230, 1.92), (830, 1.28), (1490, 0.64), (1530, 1.92), (2100, 0), (2470, 1.28), (3260, 0.64), and (4300, 0). The area between 0.64 Nm and 1.92 Nm is labeled 'Intermittent duty area', and the area below 0.64 Nm is labeled 'Continuous duty area S1'.</p>	
DC bus voltage (V)	48		
Rated power P _n (W)	200		
Rated torque T _n (Nm)	0.64		
Rated speed n _N (rpm)	3000		
Rated current I _n (A)	5.7		
Maximum torque T _m (Nm)	1.92		
Maximum current I _m (A)	18.2		
Continuous static torque T _s (Nm)	0.7		
Continuous static current I _s (A)	6.27		
Resistance line R _L (Ω)	0.68		
Inductance line L _L (mH)	1.33		
Electrical time constant τ _e (ms)	1.96		
Mechanical time constant τ _m (ms)	1.3		
	1.33 (With brake)		
Voltage constant K _e (V/krpm)	7.5		
Torque constant K _t (Nm/A)	0.124		
Rotary inertia J _m (Kg*cm ²)	0.17 (Without brake)		
	0.174 (With brake)		
Insulation grade	F		
Protection grade	IP65 Shaft end IP54		
Maximum radial force of bearing F(N)	40		
Maximum axial force of bearing F(N)	30		
Weight (Kg)	0.9		
	1.3(With brake)		

Electrical specifications of the brake

Static friction torque (Nm)	Rated voltage (VDC)	Rated power (W)	Coil resistance (Ω)	Operate Time (ms)	Release Time (ms)	Rotating clearance (°)
≥2	24±10%	7.6	75.8±10%	≤60	≤40	<1

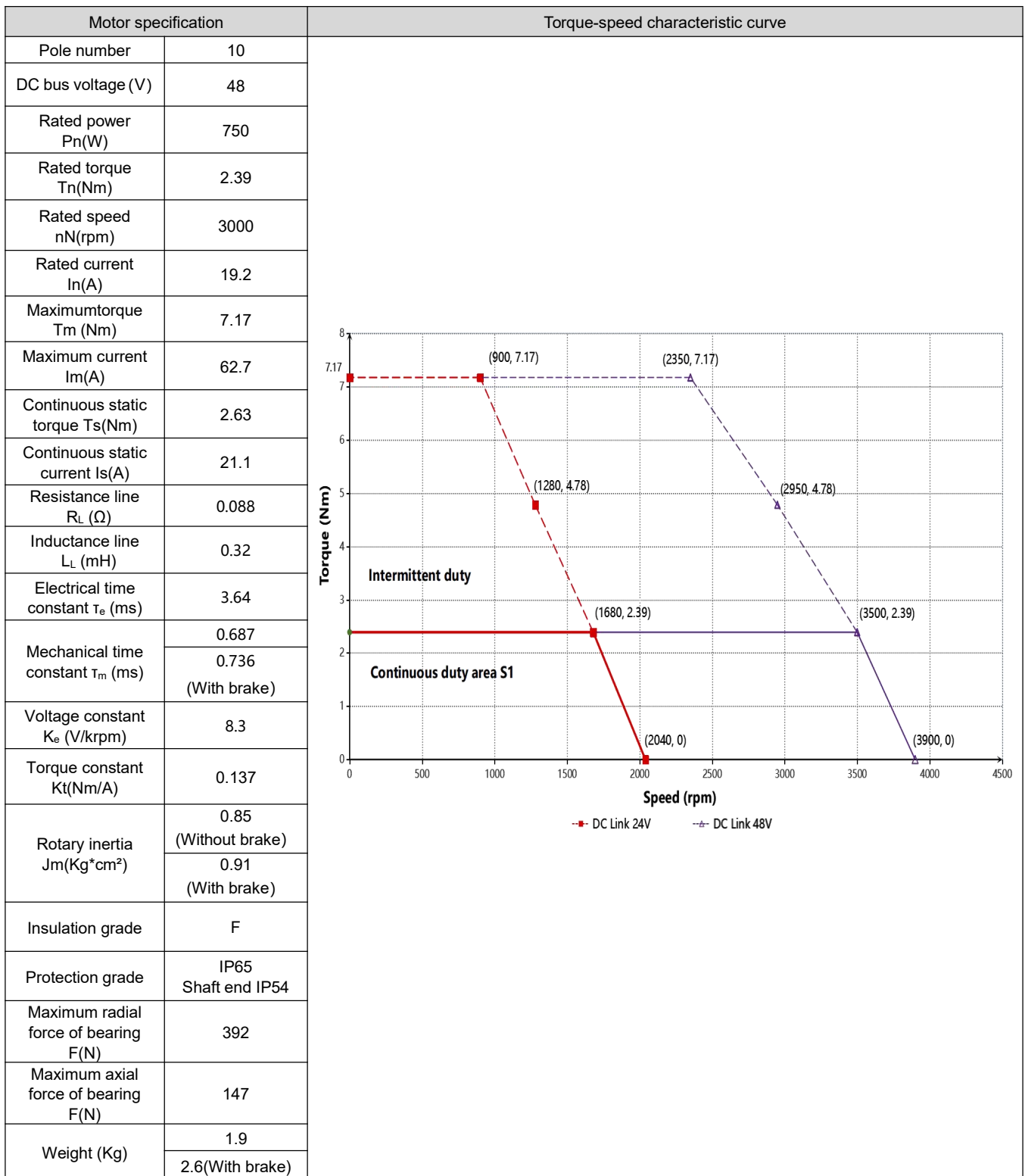
SMK60S-0040-30S■K-5DSA (The black box indicates the motor with or without brake)



Electrical specifications of the brake

Static friction torque (Nm)	Rated voltage (VDC)	Rated power (W)	Coil resistance (Ω)	Operate Time (ms)	Release Time (ms)	Rotating clearance (°)
≥2	24±10%	7.6	75.8±10%	≤60	≤40	<1

SMK80S-0075-30S■K-5DKA (The black box indicates the motor with or without brake)



Electrical specifications of the brake

Static friction torque (Nm)	Rated voltage (VDC)	Rated power (W)	Coil resistance (Ω)	Operate Time (ms)	Release Time (ms)	Rotating clearance (°)
≥4	24±10%	11.5	50±10%	≤80	≤40	<1

SMK80S-0100-30S■K-5DKA (The black box indicates the motor with or without brake)

Motor specification		Torque-speed characteristic curve	
Pole number	10	<p>The graph plots Torque (Nm) on the y-axis (0 to 12) against Speed (rpm) on the x-axis (0 to 4500). Two curves are shown: a solid red line for DC Link 24V and a dashed blue line for DC Link 48V. The 24V curve starts at (0, 9.54), has a point at (860, 9.54), then drops to (1300, 6.36), (1680, 3.18), and ends at (2050, 0). The 48V curve starts at (0, 9.54), has a point at (2500, 9.54), then drops to (3000, 6.36), (3550, 3.18), and ends at (3950, 0). A horizontal line at 3.18 Nm is labeled 'Continuous duty area S1'. The area above this line and below the curves is labeled 'Intermittent duty area'.</p>	
DC bus voltage (V)	48		
Rated power P _n (W)	1000		
Rated torque T _n (Nm)	3.18		
Rated speed n _N (rpm)	3000		
Rated current I _n (A)	25.8		
Maximum torque T _m (Nm)	9.54		
Maximum current I _m (A)	81		
Continuous static torque T _s (Nm)	3.5		
Continuous static current I _s (A)	28.4		
Resistance line R _L (Ω)	0.058		
Inductance line L _L (mH)	0.22		
Electrical time constant τ _e (ms)	3.79		
Mechanical time constant τ _m (ms)	0.63		
	0.66 (With brake)		
Voltage constant K _e (V/krpm)	8.23		
Torque constant K _t (Nm/A)	0.136		
Rotary inertia J _m (Kg*cm ²)	1.16 (Without brake)		
	1.22 (With brake)		
Insulation grade	F		
Protection grade	IP65 Shaft end IP54		
Maximum radial force of bearing F(N)	392		
Maximum axial force of bearing F(N)	147		
Weight (Kg)	2.4		
	3.1(With brake)		

Electrical specifications of the brake

Static friction torque (Nm)	Rated voltage (VDC)	Rated power (W)	Coil resistance (Ω)	Operate Time (ms)	Release Time (ms)	Rotating clearance (°)
≥4	24±10%	11.5	50±10%	≤80	≤40	<1

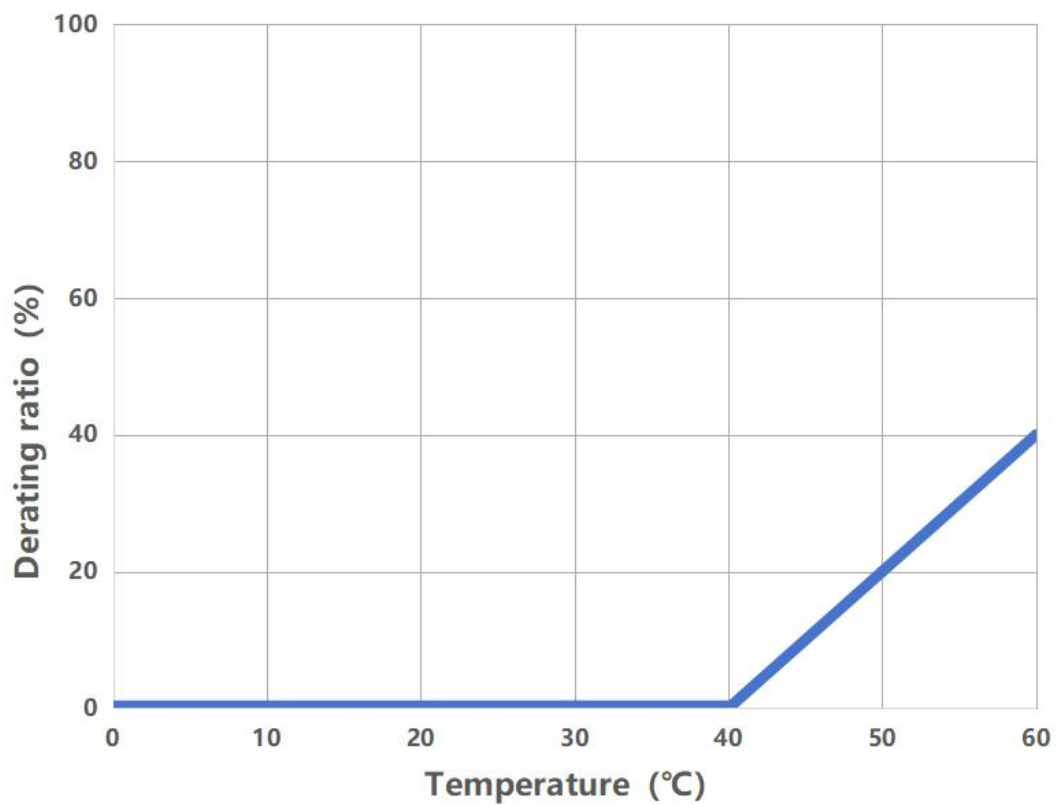
**Note**

- Influenced by the reverse electromotive force parameters of the motor, the floating range of the velocity inflection point in the TN curve is $\pm 10\%$.
- The T-N curve of the SMK motor is tested base a 1m cable.

1.3 Product characteristic

1.3.1 Derating characteristic

SMK temperature derating curve



Chapter 2 System Installation requirements and announcement

2.1 Servo system use requirements

- Ensure that this document is available to design engineers, installers, and personnel responsible for commissioning machines or systems that use the product.
- Please ensure that you always follow the requirements of this document and also consider the documentation for other components and modules.
- Please consider the legal requirements applicable to your destination and:
 - Regulations and standards
 - Test organization and insurance company regulations
 - National specifications

2.1.1 Transport and storage conditions

- Please ensure that the product is not subjected to more than permitted burdens during transportation and storage, including:
 - Mechanical load
 - The temperature is not allowed
 - Moisture
 - Corrosive gas
- Please store and transport in original packaging, which provides adequate protection against routine problems.

2.1.2 Technical requirements

The general conditions for the correct and safe use of the product must always be observed:

- The connection and environmental conditions specified in the product technical data and the technical requirements of all other connected components. Products are only allowed to operate in accordance with relevant safety procedures if they meet product specifications.
- Follow the instructions and warnings in this document.

2.1.3 Operator requirements

This product should only be operated by an electrical engineer who is familiar with the following provisions:

- Installation and operation of electrical control systems
- Applicable regulations for the operation of safe engineering systems
- Applicable provisions for accident protection and occupational safety
- Familiarize yourself with the documentation of the product

2.1.4 Announcement



Note

- Please use the servo system in a well-ventilated, dry and dust-free place, free of vibration, grinding fluid, oil mist, iron powder, chips, and immersion of moisture, oil, and water, away from the furnace and other heat sources.
- When the servo system parts are found to be incomplete or damaged, safety and use shall not be carried out.
- Do not use the servo motor in a closed environment, and the servo system must be installed in a control box in a room without rain and direct sunlight, and the surrounding must be non-flammable.
- When making mechanical connections, use a coupling or expansion sleeve and keep the shaft of the motor in line with the shaft of the machine. When installed, it meets the centering accuracy requirements. If the centering is not sufficient, it will cause vibration, which may sometimes damage bearings and encoders.
- When fixing the drive and motor, ensure that each fixing point is locked.
- Do not block the driver vent when installing the servo driver. Reserve heat dissipation space around the driver to ensure that the servo driver is not affected when installing the brake resistance.
- Avoid any foreign matter entering the servo system, screws, metal chips and other conductive foreign matter or flammable foreign matter entering the servo drive may cause fire and electric shock, for safety reasons, please do not use damaged or damaged parts of the servo drive and servo motor.
- The shaft of the motor and the shaft of the equipment must be installed in good alignment. Please use the shaft connector or the expansion sleeve.
- Do not "bend" the cable or apply "tension" to it, and do not make it too tight when wiring (in use).
- Do not use gasoline, thinner, alcohol, acid or alkaline detergent to avoid discoloration or damage to the shell.
- Improper installation may cause damage to the motor encoder. Please note the following during installation:
 - When installing pulleys on motor shafts with keyways, screw holes are used at shaft ends. In order to install the pulley, first insert the double-headed nail into the screw hole of the shaft, use a washer on the surface of the coupling end, and gradually lock the pulley with a nut.
 - ◆ For motor shafts with keyways, install them using screw holes at shaft ends. For shafts without keyways, frictional coupling or similar methods are used.
 - ◆ When the pulley is removed, the pulley removal device is used to prevent the bearing from being strongly impacted by the load.
 - ◆ To ensure safety, install a protective cover or similar device in the rotating area, such as a pulley mounted on the shaft.
- When used in places with water drops, please use it on the basis of confirming the protection level of the servo motor. (except shaft through) Specify servo-products with oil seals for use in areas where oil droplets may drip onto shaft through parts. Conditions of use of oil seal:
 - ◆ Make sure the oil level is lower than the lip of the oil seal when using.
 - ◆ Use in a condition where the oil seal can keep the oil spray level good.
 - ◆ When the servo motor is installed vertically, please be careful not to make the oil seal lip oil.

2.1.5 Oil seal installation instructions

The bearing of the motor has a double-sided dust proof effect, and the assembly of the oil seal will increase the loss of the motor, resulting in a decrease in the efficiency of the motor, if it is not necessary to install the oil seal, it is not recommended to install the oil seal. Before assembling the oil seal, please ensure that the installation hole and the oil seal are free of debris, oil, dust, etc. Incorrect installation of the oil seal may cause abnormal operation of the motor (such as the no-load running current increases, and the temperature rise of the motor shaft increases). Please install the oil seal correctly according to the following steps:

1. Before the oil seal installation, grease is evenly applied in the oil seal lip and the outer circle of the seal (recommended to use HP-R of the Great Wall, temperature resistance of 180 degrees of grease) to strengthen the performance of lubrication and temperature resistance, increase the sealing and waterproof effect of the oil seal, and at the same time, appropriate amount of grease is also applied to the motor shaft oil seal location, front end cover and oil seal chamber.
2. When installing the oil seal, the side of the oil seal with the spring should be oriented towards the motor, select the appropriate sleeve specification, and put the oil seal on the sleeve to ensure that the seal lip will not be damaged.
3. After the sleeve with the oil seal is put into the motor shaft, the oil seal is slowly pressed into the oil seal chamber with the press assembly tool. Pay attention to ensure that the oil seal is perpendicular to the machine shaft. The purpose of using the framework oil seal press assembly tool is to ensure that the oil seal is pushed into the chamber with uniform force.
4. After successful installation, check whether the oil seal will tilt, the oil seal should be fitted with the motor bearing cover, and the lip of the oil seal should be completely closed to ensure the tightness of the oil seal.

Shaft Seal Installation
油封安装示意图

Flang Size	ID	OD	L
60mm	16mm	32mm	50mm
80mm	21mm	42mm	50mm

Oil seal installation instructions
油封安装说明

1. Seal must be fitted with gaiter spring visible from inside of motor.
油封安装时，使油封有弹簧的一面朝向电机。
2. Ensure that seal is lubricated sufficiently for installation and initial start-up. (HP-R lubricants of Sinopec is recommended)
确保油封安装前充分润滑。(推荐使用长城HP-R润滑油)
3. Sealing lip must be protected from damage during installation by use of suitable sleeve over shaft. Specifications of sleeve refer to shaft seal installation flow chart printed on opposite page.
在安装过程中必须用合适的套筒，确保密封唇不被损坏，套筒规格见反面《油封安装示意图》中所示。
4. Firmly support rear of motor on suitable press, taking care to avoid damage to connectors.
在电机后端用合适的压力支撑，同时避免损坏电机插头。

WARNING:
Under no circumstances attempt to hammer seal into position.
警告：
任何情况下，严禁敲击油封至油封室内。

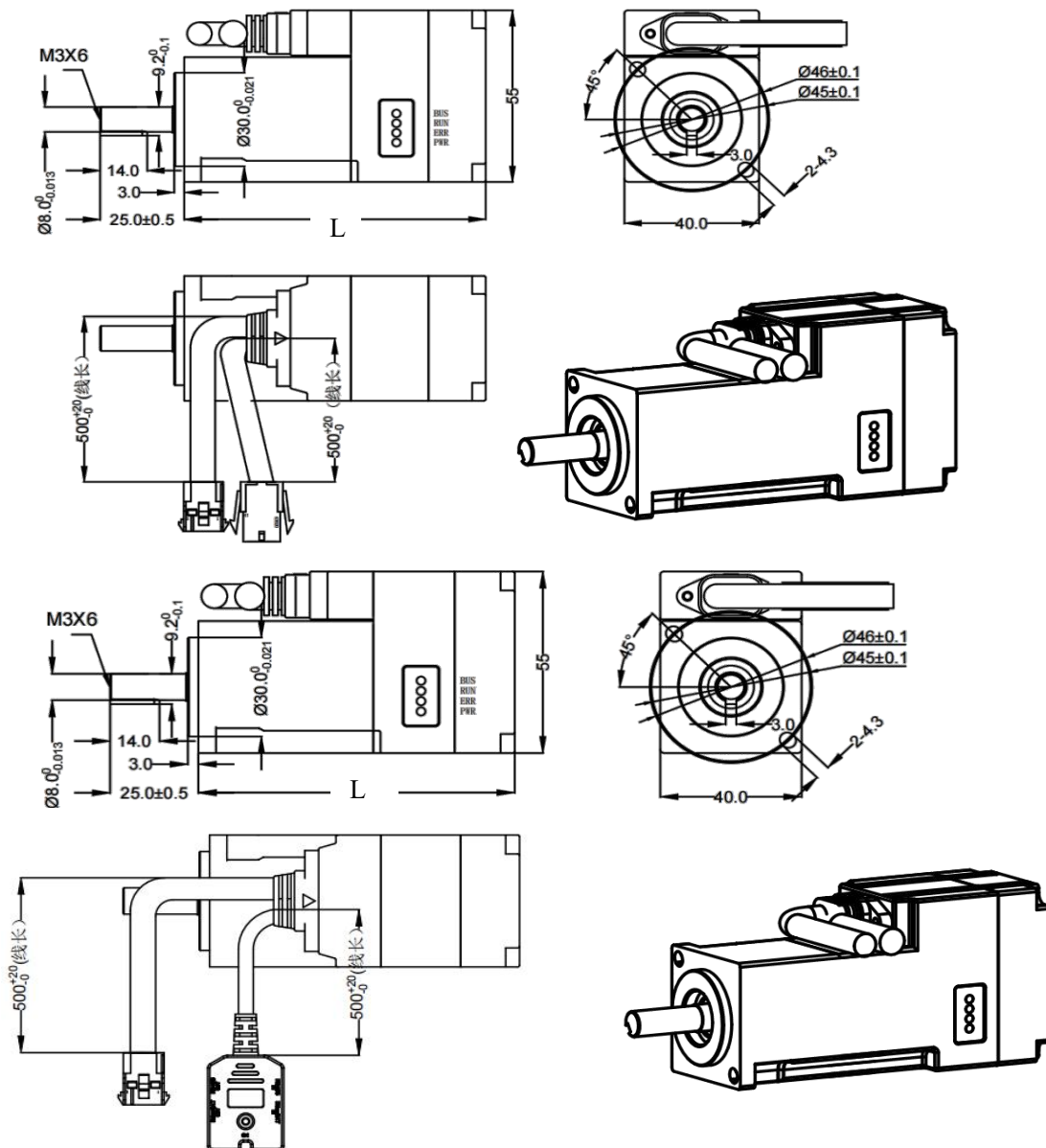


Note

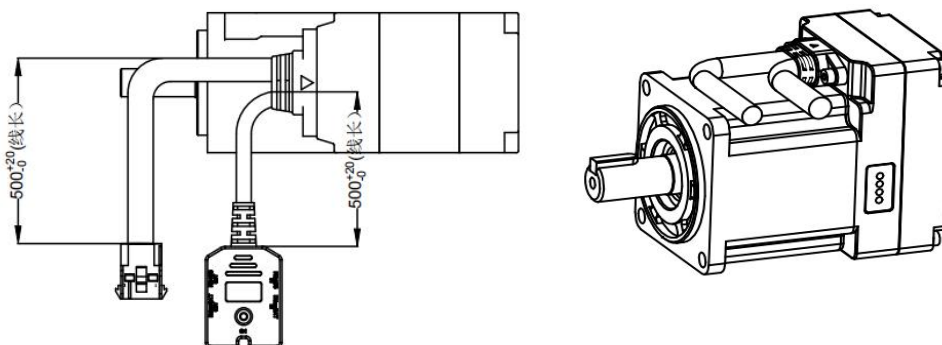
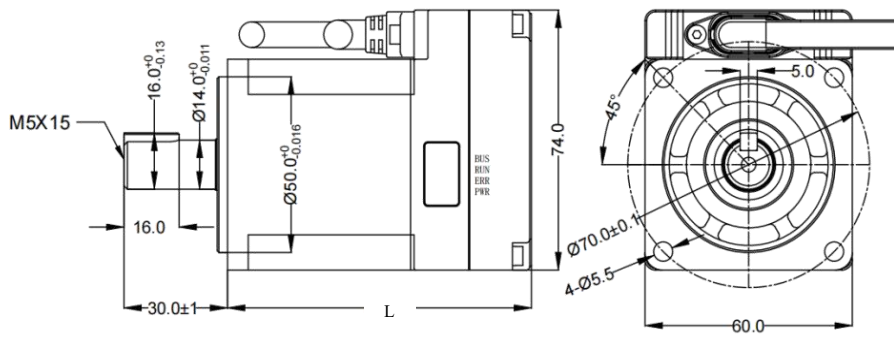
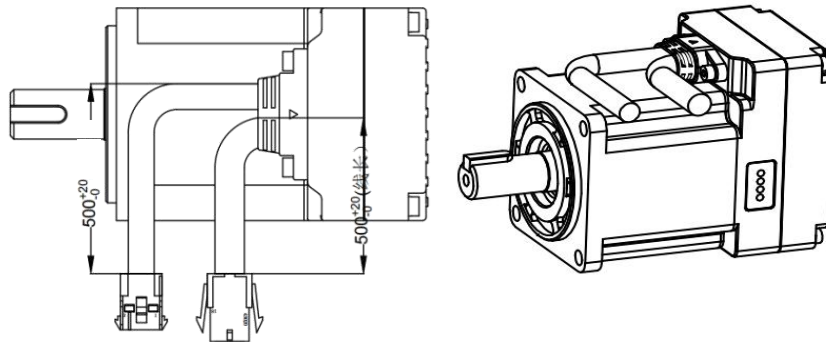
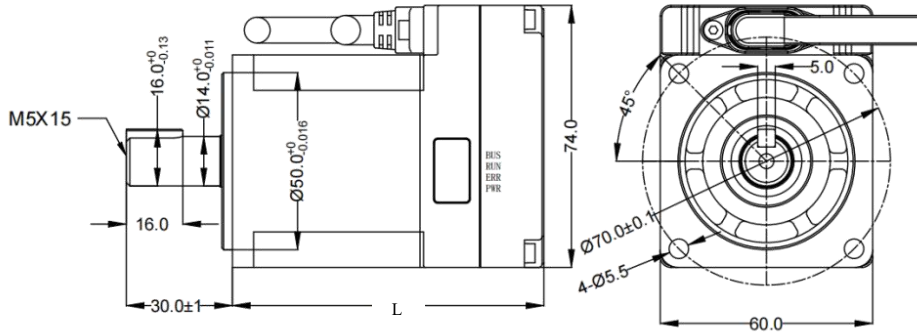
- Before installing the oil seal, ensure that experienced personnel install the oil seal according to correct steps to prevent damage to the motor or the oil seal.
- Do not use a hammer to directly hit the oil seal for assembly. Direct tapping will cause deformation of the oil seal, scratches on the outer diameter of the oil seal and the seal lip, and the spring of the oil seal.
- When installing the oil seal, the oil seal must be placed horizontally and then installed under uniform pressure. If the oil seal is forcibly installed in the skewed state, it will cause the deformation of the oil seal and thus fail.
- If no professional tools can be installed, use a stop plate on the oil seal, and evenly apply force to knock the oil seal into the oil seal chamber.
- iSMK oil seals are not assembled by default, and are assembled by customers according to their needs.

2.2 Servo system mounting dimensions

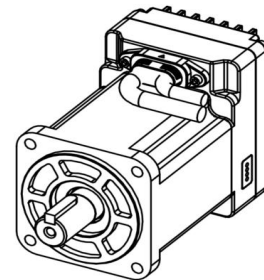
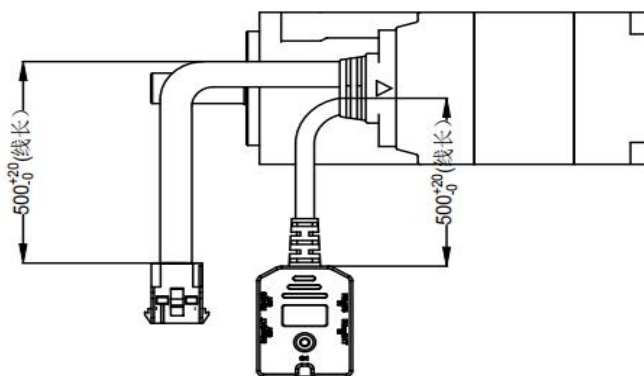
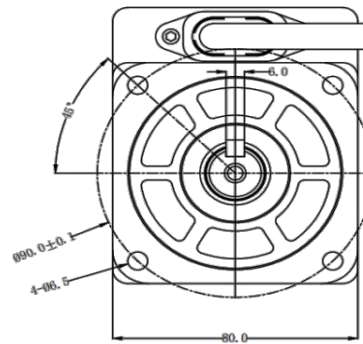
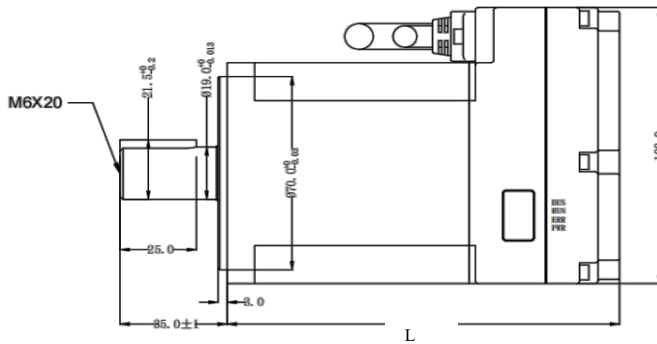
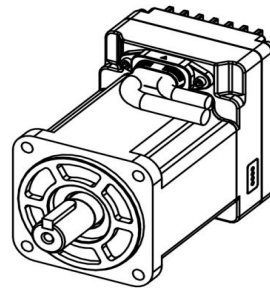
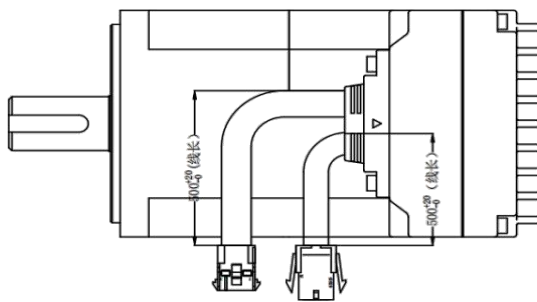
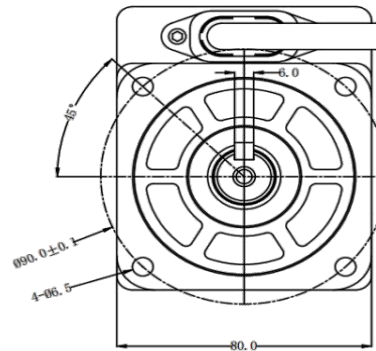
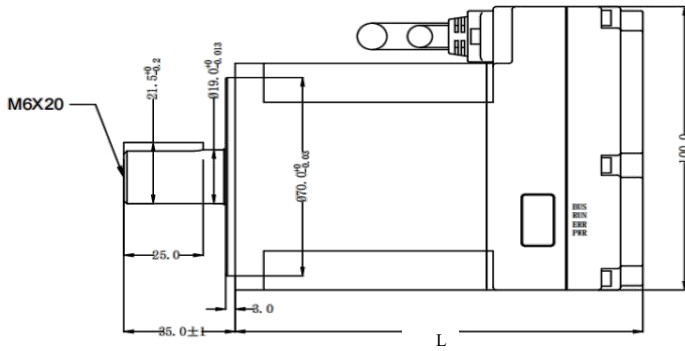
2.2.1 iSMK series mechanical dimensions



iSMK40 series model	With brake	Approx weight (Kg)	Overall dimension L (mm)
iSMK40-010-DMAK-AA-000		0.6	90
iSMK40-010-DMBK-AA-000	√	0.8	126
iSMK40-010-DMAK-EA-000		0.7	90
iSMK40-010-DMBK-EA-000	√	0.9	126



iSMK60 series model	With brake	Approx weight (Kg)	Overall dimension L (mm)
iSMK60-020-DMAK-AA-000		1.1	88
iSMK60-020-DMBK-AA-000	√	1.6	127.5
iSMK60-020-DMAK-EA-000		1.2	88
iSMK60-020-DMBK-EA-000	√	1.7	127.5
iSMK60-040-DMAK-AA-000		1.3	106
iSMK60-040-DMBK-AA-000	√	1.8	145.5
iSMK60-040-DMAK-EA-000		1.4	106
iSMK60-040-DMBK-EA-000	√	1.9	145.5



iSMK80 series model	With brake	Approx weight (Kg)	Overall dimension L (mm)
iSMK80-075-DMAK-AA-000		2.5	128
iSMK80-075-DMBK-AA-000	√	3	158
iSMK80-075-DMAK-EA-000		2.6	128
iSMK80-075-DMBK-EA-000	√	3.1	158

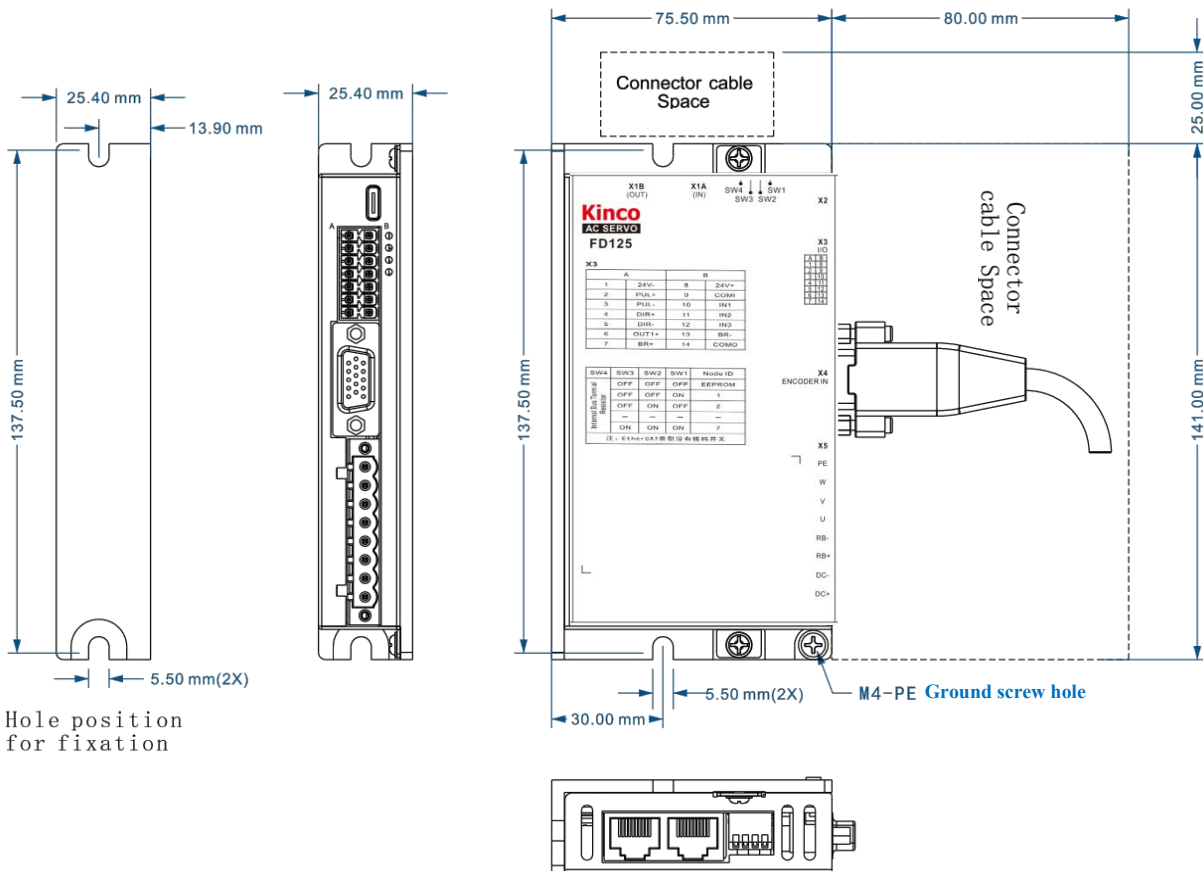


Note

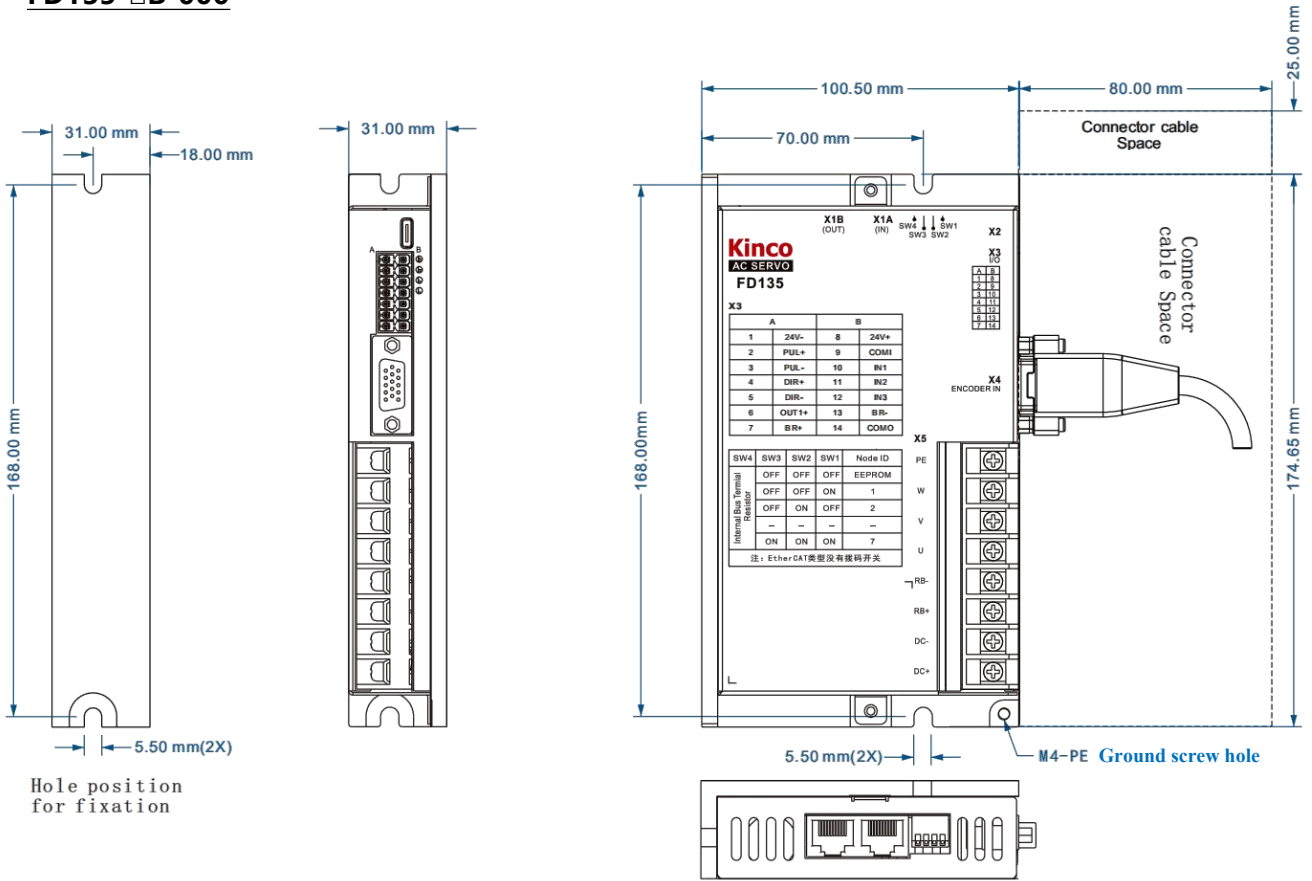
- It is recommended to install the integrated motor upright or sideways to ensure a well-ventilated installation environment.
- In order to ensure good heat dissipation of the motor, the installation distance between the two machines should be not less than 30mm.
- When the integrated motor overheats frequently, it indicates that heat dissipation needs to be enhanced. A fan can be installed near the motor to force heat dissipation to ensure that the driver works within a reliable operating temperature range.

2.2.2 FD1X5 series mechanical dimension

FD125-□B-000

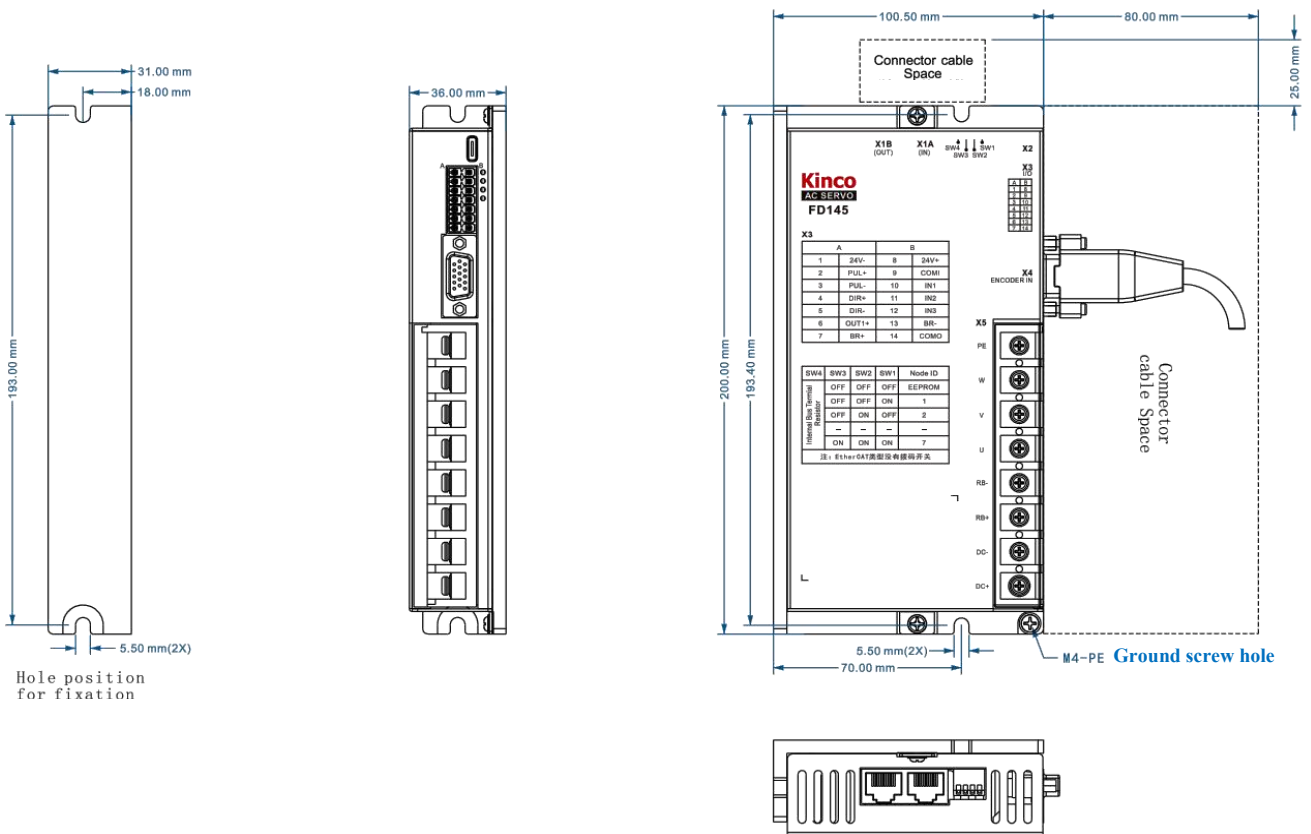


FD135-□B-000



Hole position for fixation

FD145-□B-000



Hole position for fixation



Note

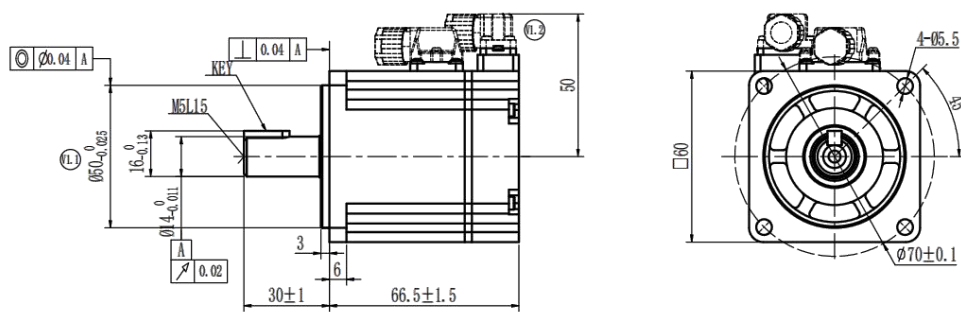
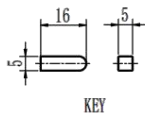
- When the driver is installed on the wall, it must be placed vertically, and the upper and lower spacing must be reserved.
- If you use thermal devices such as brake resistors, the heat dissipation situation should be fully taken into account to ensure the heat dissipation space of the driver and ensure that the driver is not affected. (Unit: mm)
- FD1X5-EB-000 drive has no dip switch



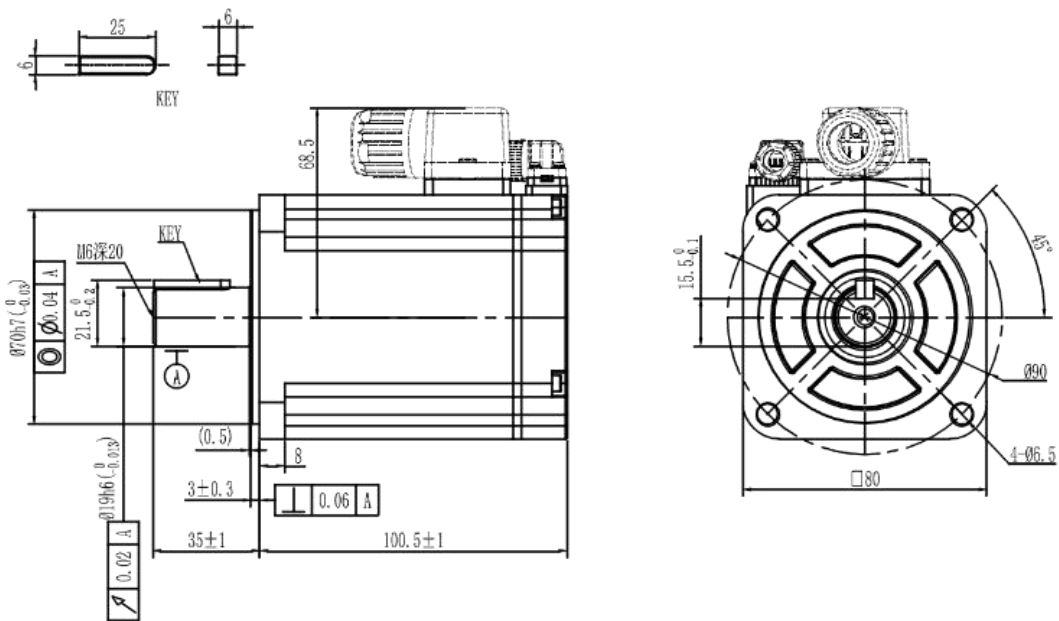
Warning

- Ensure that the driver is securely installed and screwed. Otherwise, the driver may fall and be hurt.
- Pay attention to the danger of electric shock. Disconnect the power supply when connecting the cable. Contact with live parts can cause serious injury and may result in death.
- The product must be installed in the electric box when used, and all protective measures have been activated.
- In the event of maintenance, repair and cleaning work and prolonged service interruption, the power supply of electrical equipment should be turned off by the power switch before contact with live parts and prevent it from being turned on again.
- During installation, avoid any foreign matter entering the servo drive. Electrically conductive foreign matter such as screws, metal chips or combustible foreign matter entering the servo drive may cause fire and electric shock.
- Please do not use damaged or damaged servo drives and servo motors.
- The motor power cord and encoder cable of the driver should be fixed and not overextended.
- The servo driver must be well grounded.

2.2.3 Motor mechanical dimensions



SMK60 series model	With brake	Overall dimension (mm)
SMK60S-0020-30SAK-5DSA		66.5 ± 1.5
SMK60S-0020-30SBK-5DSA	√	98 ± 1.5
SMK60S-0040-30SAK-5DSA		89 ± 1.5
SMK60S-0040-30SBK-5DSA	√	116 ± 1.5



SMK80 series model	With brake	Overall dimension (mm)
SMK80S-0075-30SAK-5DKA		100.5±1
SMK80S-0075-30SBK-5DKA	√	134.5±1
SMK80S-0100-30SAK-5DKA		112.5±1
SMK80S-0100-30SBK-5DKA	√	146.5±1

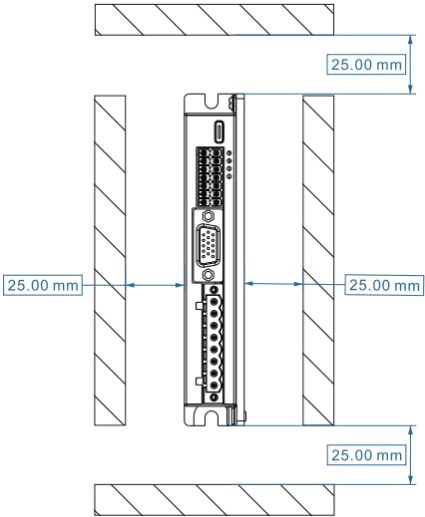
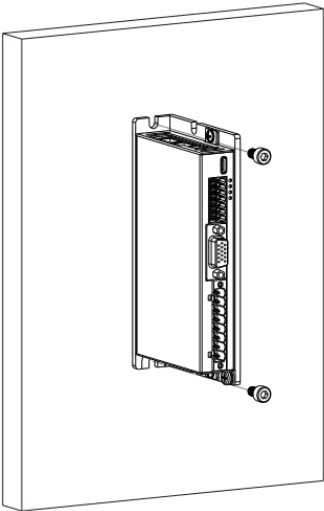
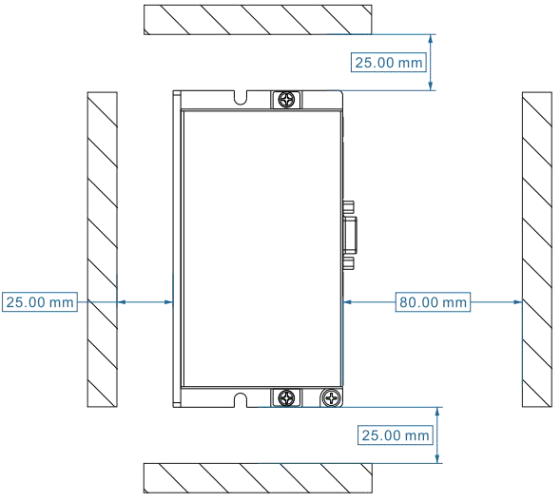
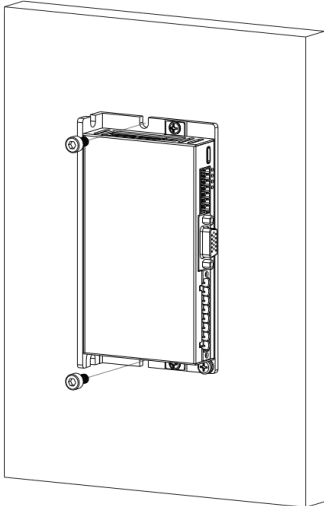
2.3 Driver installation spacing and auxiliary heat dissipation

2.3.1 FD1X5 series driver installation spacing

There are two ways to install the servo drive of the FD1X5 series: vertical installation or horizontal installation, and the hole should be drilled according to the hole position for fixation in the product size drawing.

When the driver is installed vertically, a gap of 25mm should be reserved between the driver and the wall/cabinet. When the driver is horizontally installed, leave a gap of 25mm between the sides without network ports and the wall/cabinet surfaces, and 80mm between the side with network ports and the wall/cabinet surfaces. The spacing and installation methods are as follows

Table 2-1 FD1X5 driver installation spacing and method

Installation spacing	Installation method
Vertical installation	
 <p>Technical drawing showing the vertical installation of the driver. The driver is mounted on a panel with a 25.00 mm spacing between the driver and the panel on all four sides (top, bottom, left, and right).</p>	 <p>3D perspective view of the driver installed vertically in a panel, showing the driver mounted on the panel with screws.</p>
Horizontal installation	
 <p>Technical drawing showing the horizontal installation of the driver. The driver is mounted on a panel with a 25.00 mm spacing between the driver and the panel on the top, bottom, and left sides, and an 80.00 mm spacing between the driver and the panel on the right side.</p>	 <p>3D perspective view of the driver installed horizontally in a panel, showing the driver mounted on the panel with screws.</p>

2.3.1.1 Auxiliary heat dissipation description

The output currents for the FD125, FD135 and FD145 are 15Arms, 30Arms and 50Arms respectively. These values were measured with the driver mounted on a 300mm*300mm*10mm (L*W*H) black oxide 6063 aluminum plate auxiliary heatsink.

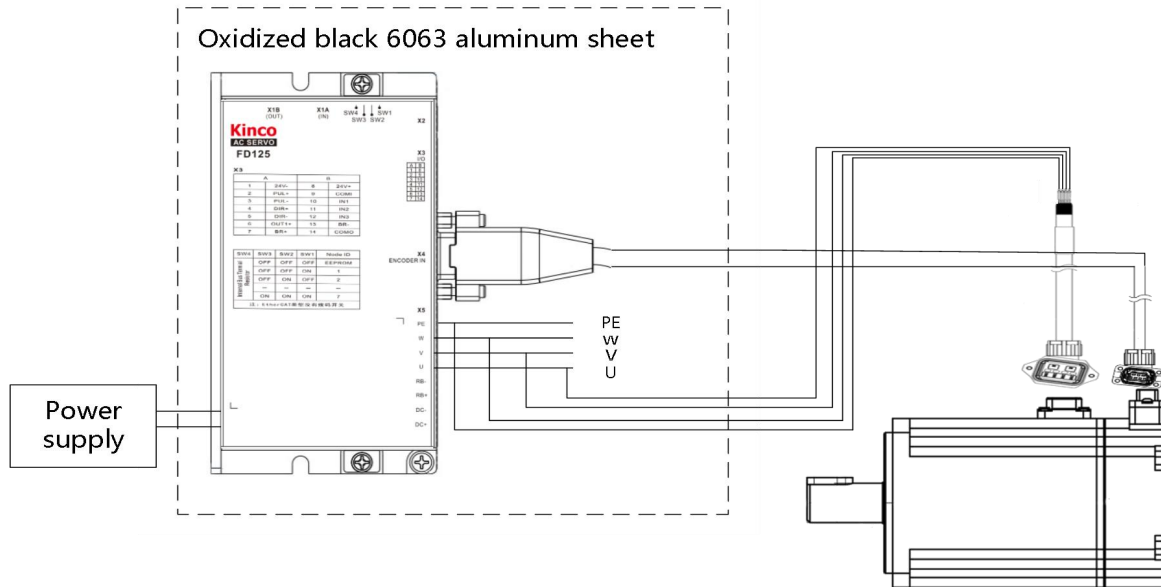
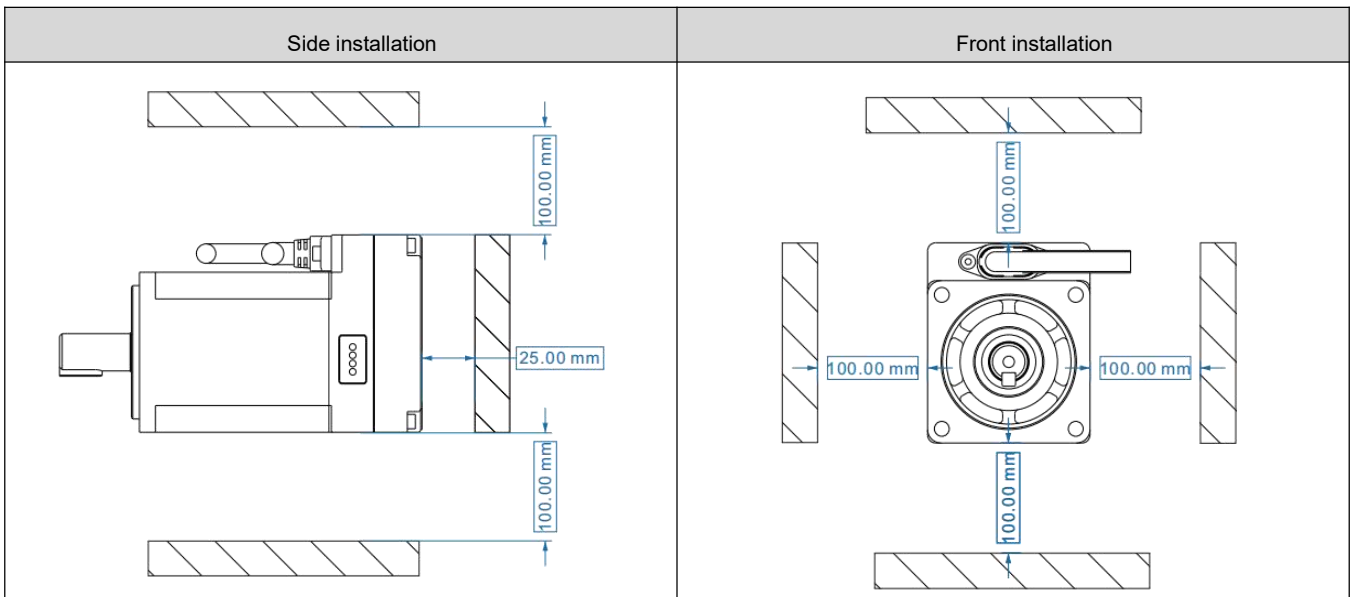


Figure 2-1 Auxiliary heat dissipation installation diagram

2.3.2 iSMK Series installation spacing

iSMK series has two mounting methods: side installation and front installation, for side installation, there should be a gap of 100mm between the top and bottom of the wall/cabinet, and a gap of 25mm between the base and the wall/cabinet; For front installation, leave a gap of 100mm between each side and the wall/cabinet. The following figure shows the installation spacing.

Table 2-2 iSMK installation spacing



2.3.2.1 iSMK auxiliary heat dissipation description

The iSMK60 is installed on a 254mm* 254mm* 8mm (L*W*H) black oxide aluminum plate for auxiliary heat dissipation, and the iSMK80 is installed on a 254mm* 254mm* 12mm (L*W*H) black oxide aluminum plate for auxiliary heat dissipation, as shown in the following figure

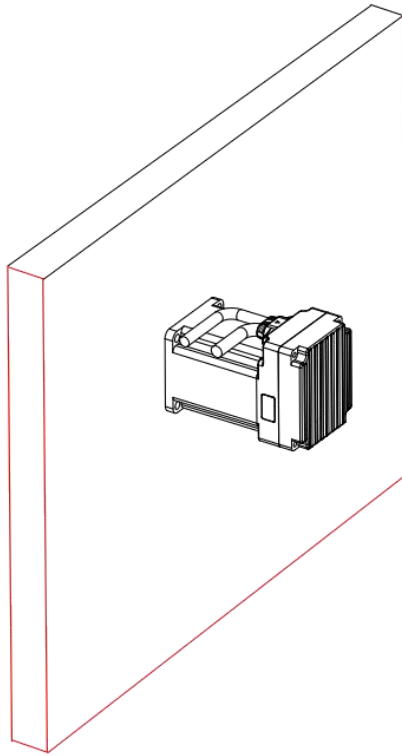


Figure 2-2 iSMK auxiliary heat dissipation installation

Chapter 3 System interface and wiring

3.1 iSMK series system interface and wiring

3.1.1 Part name

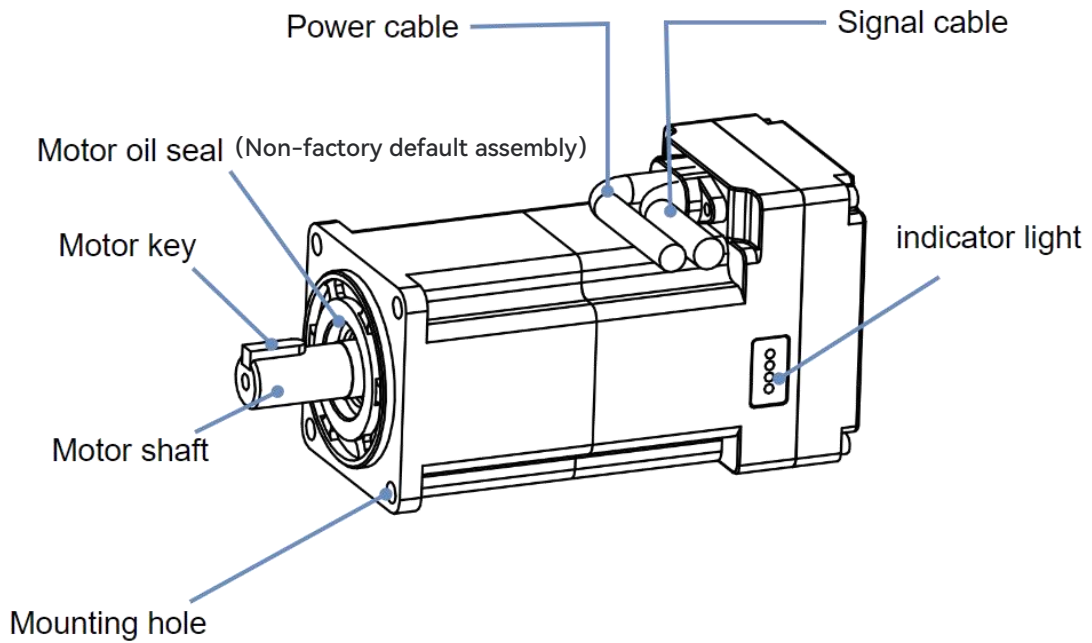
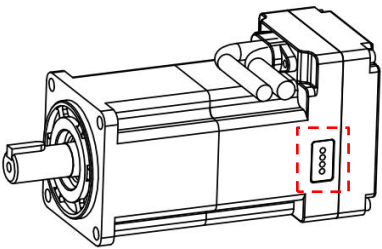


Figure 3-1 iSMK series part name

Table 3-1 Indicator light description

	BUS(green)	When packets are transmitted on the bus, the blinking frequency is related to the packet transmission speed
	RUN(green)	The drive is always bright when it is in the ready state and is associated with the OUT3 port
	ERR(red)	The drive is always bright when it is in the error state, which is associated with the OUT4 port
	PWR(green)	The drive is powered on and the POWER indicator is steady on

3.1.2 External wiring diagram

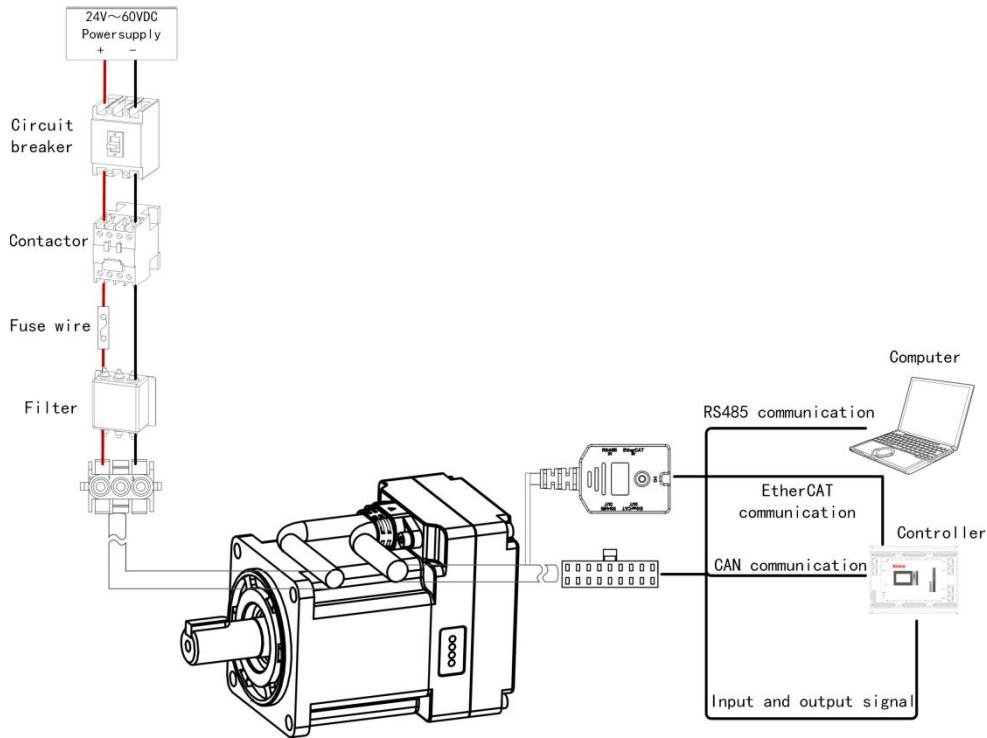


Figure 3-2 iSMK-AA/EA series external connection mode

3.1.3 Cable model and terminal description

iSMK series integrated motor leads two cables from the body: the power cable and the signal cable. Among them, the brake cable required for the motor with brake will be integrated into the signal cable, which greatly saves the wiring space, and the corresponding external cable can be used when using this series of motors. The bending radius of the signal cable is 4OD, the bending radius of the power cable is 6OD (OD indicates the outer diameter of the cable), The terminal definition for power cable and signal cable are as follows.

1. Power cable

Table 3-2 iSMK power cable terminal definition (Motor end)

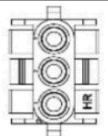
	Integrated machine	Cable color	Singal	
	Power cable terminal PIN			
	1	Red	48V+	
3	Black	48V-		

Table 3-3 iSMK-AA series power cable(Extension cable)

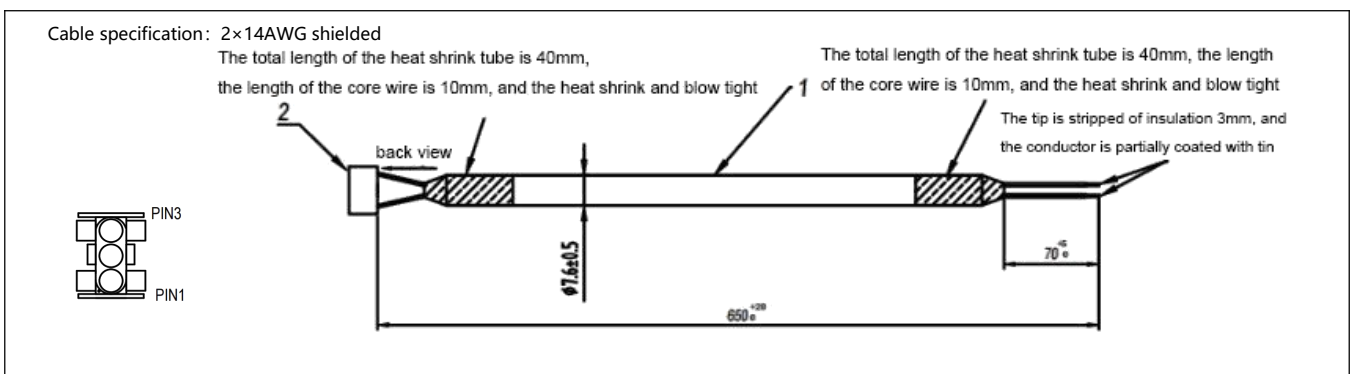
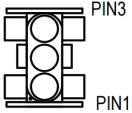
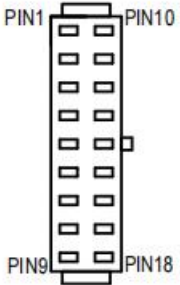


Table 3-4 iSMK-AA series terminal definition (Extension cable)

	Power cord terminal PIN		Cable color	Singal
	1		Red	48V+
	3		Black	48V-

2. Signal cable

Table 3-5 iSMK-AA series signal cable terminal definition (Motor end)

	A			B		
	Pin	Name	Cable color	Pin	Name	Cable color
	1	24V	Red	10	GND	Black
	2	Lock+	Purple	11	Lock -	Purple and black
	3	CANH	Blue and black	12	CANL	Blue
	4	CANH		13	CANL	
	5	RS485A	Orange and black	14	RS485B	Orange
	6	RS485A		15	RS485B	
	7	OUT1+	Yellow and black	16	COMO	Yellow
	8	COMI	White	17	DI1	Green
9	GNDC	Green and black	18	DI2	White and black	

Cable specification : 10Px28AWG

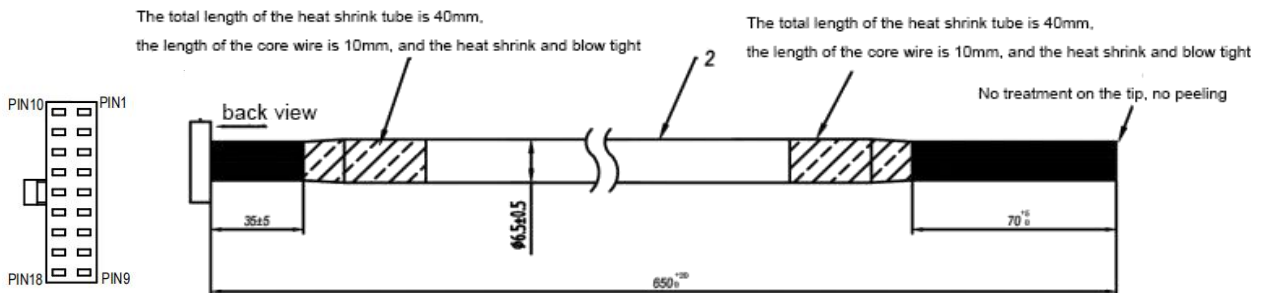


Figure 3-3 iSMK-AA series signal cable (Extension cable)

Table 3-6 iSMK-AA series singal cable terminal definition(Extension cable)

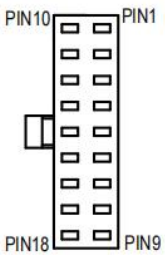
	A			B		
	Pin	Name	Cable color	Pin	Name	Cable color
	1	24V	Red	10	GND	Black
	2	Lock+	Brown	11	Lock -	Blue
	3	CANH	Light green	12	CANL	Light blue
	4	CANH	Pink	13	CANL	White and black
	5	RS485A	Yellow	14	RS485B	Green
	6	RS485A	Gray	15	RS485B	White
	7	OUT1+	Purple	16	COMO	Orange
	8	COMI	White and brown	17	DI1	White and red
9	GNDC	White and green	18	DI2	White and orange	

Table 3-7 iSMK-EA series signal cable IO terminal definition (Motor end)

	A		B	
	Pin	Name	Pin	Name
	1	24V	10	GND
	2	Lock+	11	Lock -
	3	-	12	-
	4	-	13	-
	5	RS485A	14	RS485B
	6	RS485A	15	RS485B
	7	OUT1+	16	COMO
	8	COMI	17	DI1
9	GNDC	18	DI2	

Table 3-8 iSMK-EA series signal cable communication terminal definition (Motor end)

	Pin	RS485 IN/ RS485 OUT	EtherCAT IN	EtherCAT OUT
	1	-	IN TX+	OUT TX+
	2	-	IN TX-	OUT TX-
	3	-	IN RX+	OUT RX+
	4	GND_C	-	-
	5	RS485B	-	-
	6	RS485A	IN RX-	OUT RX-
	7	-	-	-
	8	-	-	-



Note

- iSMK-EA series integrated motor has a PCB board inside, so the cable color of the IO port of the fuselage is not explained.

Table 3-9 IO terminal detailed description

Pin	Name	Pin specification
1	24V	24V logic power input The logic power supply is an optional option. When using the logic power supply, ensure that the power supply and logic are completely isolated. If the system power supply is not isolated, the logical ground cable is not connected. The logic power supply is connected at DC- and 24V
10	GND	Logic electrical reference ground
2	Lock+	External release beake input (24V+) positive The input voltage is 24V, the maximum input current is 0.7A, only when the AGV body battery is out of emergency use; Only when both the logic power supply and the power supply are powered off, the external lock can be unlocked. Do not short-circuit or connect to other signals and enclosures during normal operation
11	Lock -	External release gate input (24V-) negative The input voltage is 24V, the maximum input current is 0.7A, only when the AGV body battery is out of emergency use; Only when both the logic power supply and the power supply are powered off, the external lock can be unlocked. Do not short-circuit or connect to other signals and enclosures during normal operation
3	CANH	CAN signal positive end (only the iSMK-AA series has this pin)
4		
12	CANL	CAN signal negative end (only the iSMK-AA series has this pin)
13		
5	RS485A	RS485 data positive end
6		
14	RS485B	RS485 data negative end
15		
7	OUT1+	Digital signal output, OUT1 for the open collector output, the highest voltage 30V, driving capacity of 100mA
16	COMO	Digital signal output common terminal
8	COMI	Digital signal input to the common end

9	GNDC	Signal ground
17	DI1	Digital signal input, COMI terminal; High level: 12.5 ~ 30VDC Low level: 0 ~ 5VDC Input impedance: 5KΩ Maximum frequency: 1KHz
18	DI2	

Note
If users need to make their own cables, please contact our personnel to obtain the relevant cable drawings!

3.1.4 Electrical wiring

Figure 3-4 shows the input and output electrical cables of iSMK series motors (iSMK-EA series without CAN_H and CAN_L pins).When there is a lot of interference in field applications, twisted pair cables are recommended for control signals to reduce interference from interference sources to control signals.

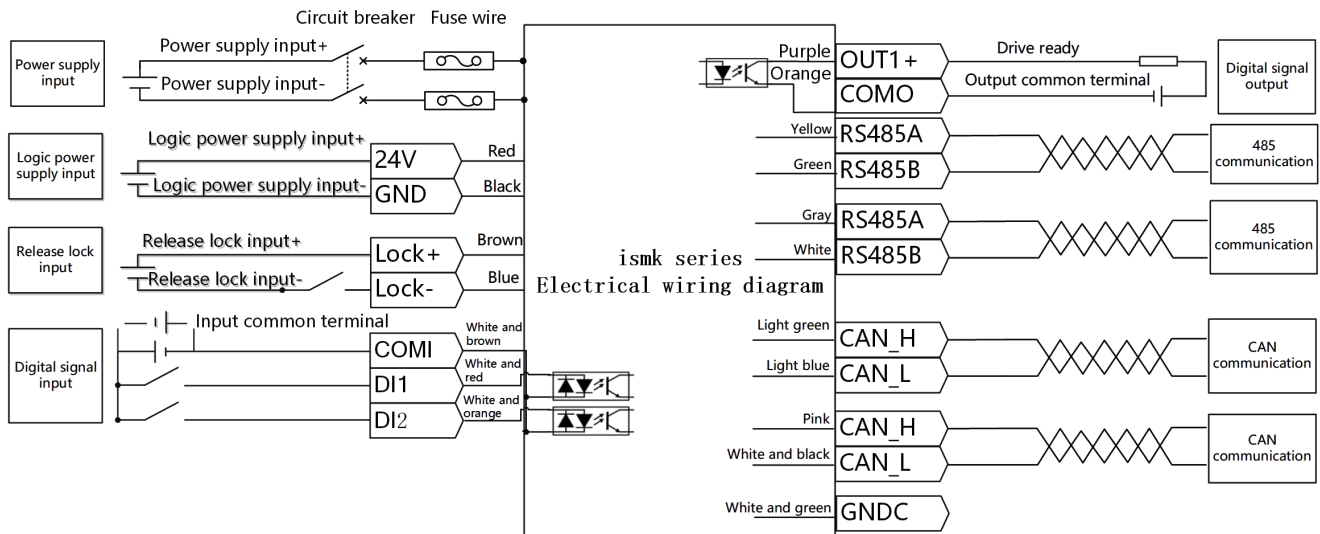


Figure 3-4 iSMK series Electrical wiring diagram

Note

- When wiring, to avoid interference, please follow the principle of strong current (motor phase line and power line) and weak current isolation wiring (at least 10 cm apart).
- Do not insert or remove cables when live. Otherwise, equipment damage and personal injury may be caused. Pay special attention to the motor in the locked state, the motor power line still has a large current.
- The iSMK series driver is a device that accesses power to drive the internal motor lock. If external manual lock release is required, it should be noted that the driver cannot access the power supply. Manual forced lock release is only used in emergency situations.
- When the external lock of iSMK series drivers is released, the power supply voltage must be 24V. When the voltage exceeds 24V, the lock coil will be damaged in high temperature. The wiring diagram of the forced external release brake is as follows:

Table 3-10 Digital input and output signal wiring example

Digital signal input wiring	
Description	Digital input port High level input voltage range: 12.5-30VDC; Low input voltage range: 0-5VDC; Maximum frequency: 1KHz
The upper computer is relay output	
The upper computer is open collector output	<p style="text-align: right;">NPN</p>
	<p style="text-align: right;">PNP</p>
Digital signal output wiring	
Description	Digital signal output, OUT1 for the open collector output, the highest voltage 30V, driving capacity of 100mA
The upper computer is relay input	
The upper computer is optocoupler input	<p style="text-align: right;">NPN</p>
	<p style="text-align: right;">PNP</p>

3.2 FD1X5 series system interface and wiring

3.2.1 Part name

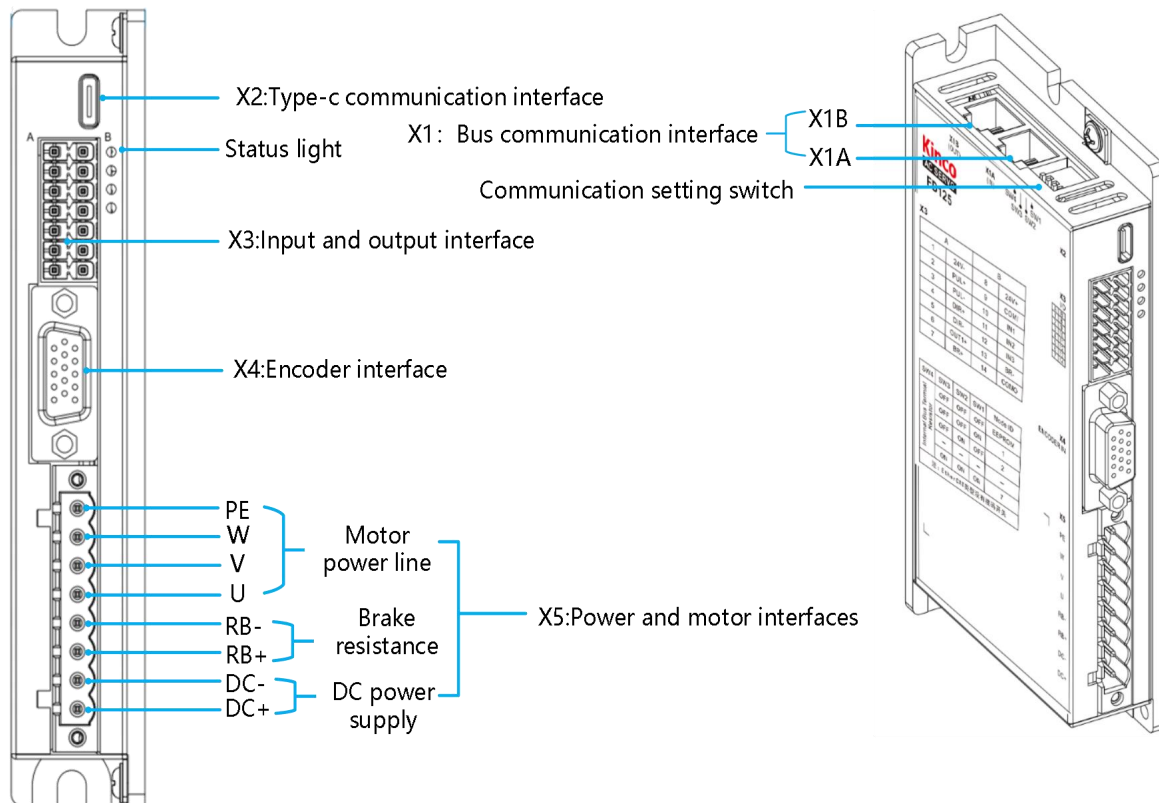


Figure 3-5 FD1X5 series part name

Table 3-11 status light Description

From top to bottom	ERR (Red)	When the driver reports an error, it is in the steady state and is associated with the OUT4 port
	RUN (Green)	When the drive is ready, it is in the steady state and associated with the OUT3 port
	PWR (Green)	The drive is powered on and the POWER indicator is steady on
	BUS (Green)	When packets are transmitted on the CAN bus, the blinking frequency is related to the packet transmission speed

Table 3-12 DIP switch description (Only applicable to FD1X5-AB-000)

SW1~SW3	They are used to set the drive ID. When SW1 to SW3 are OFF, the drive reads the ID in the EEPROM
SW4	Turn on or off the driver built-in terminal resistor

3.2.2 External wiring diagram

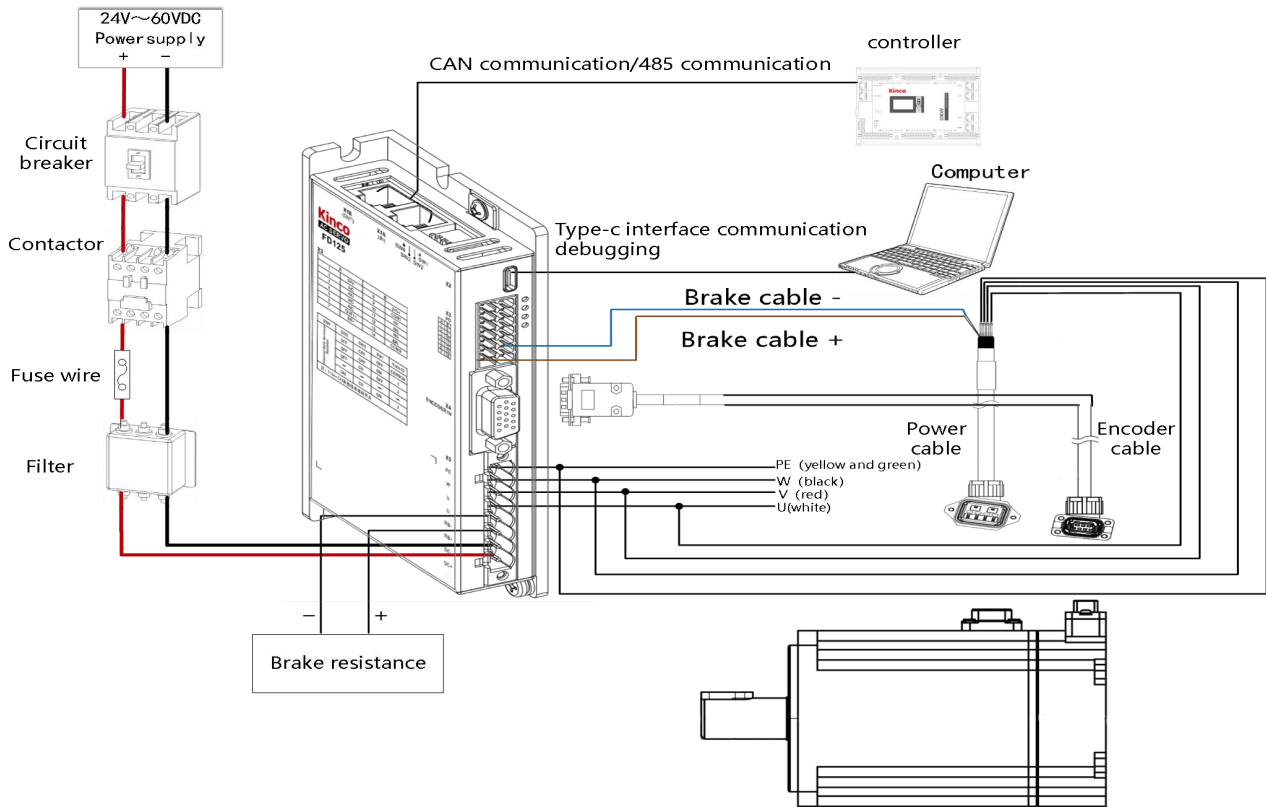


Figure 3-6 FD1X5 series external wiring diagram

3.2.2.1 Brake resistance selection

The energy generated by the servo motor in the braking state will be fed back to the DC bus of the driver. When the voltage of the DC bus exceeds the protection range, the driver will report that the bus voltage is too high and the excess energy needs to be absorbed by an external brake resistor. When the external brake resistance is used, the brake resistance resistance value and brake resistance power can be set at the driver end, and the driver will turn on the brake resistance overtemperature protection function according to the set resistance value and power. It should be noted that the resistance value of the optional external brake resistor cannot be lower than the recommended resistance value.

Table 3-13 Recommended specifications for braking resistor

Driver type	Minimum resistance of brake resistance [Ω]	Brake resistance power [W]	Brake resistance voltage [VDC] (minimum value)
FD125	10	100	500
FD135	5	100	500
FD145	3.5	200	500

Table 3-14 Brake resistance parameters

Address	Name	Bits	Modbus address	Command Type	Unit	Description
60F70110	Brake resistance resistance value	Unsigned16	0x6010	RW	Ω	You can enter the resistance value and power of the external brake resistance. The default value is 0, indicating that the external brake resistance power and temperature detection are disabled
60F70210	Brake resistance power	Unsigned16	0x6020	RW	W	
60F70310	Brake resistance time constant	Unsigned16	0x6030	RW	S	External brake resistance time constant S=DEC*256/1000

Note



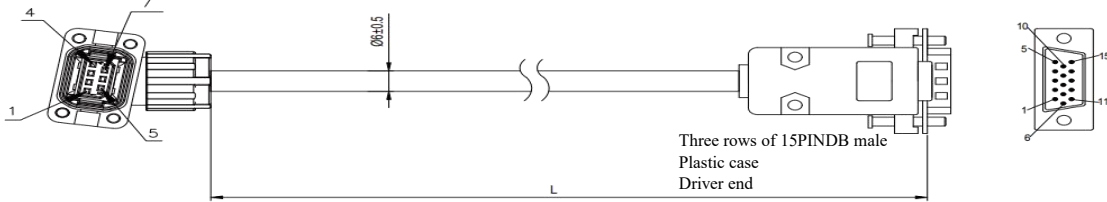
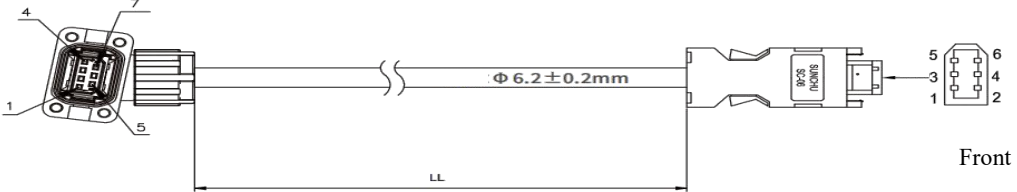
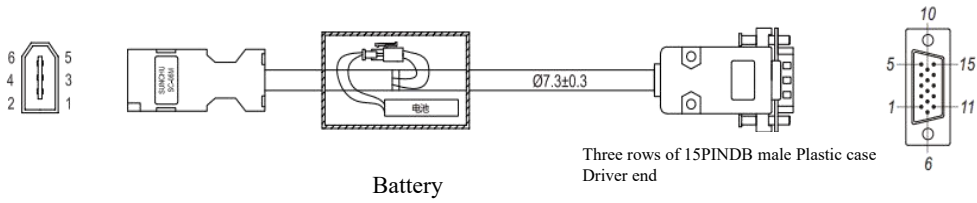
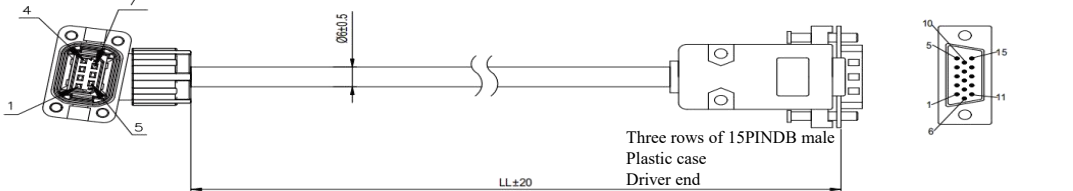
- The chopper voltage setting must be greater than the actual input voltage of the driver, otherwise it will cause brake resistance or drive damage.

3.2.3 Cable Description

The FD1X5 series driver comes with two cables: power cable and encoder cable. For a motor with a brake, the power cable also contains two brake cables. For ordinary or standard cables, the bending radius must be greater than 5 x OD mm (OD indicates the outer diameter of the cable). For flexible cable, the bending radius can be fixed or moved. The bending radius must be greater than 5 x OD mm for fixed installation and greater than 10 x OD mm for mobile installation. Power cable and encoder cable specifications are as follows.

1. Encoder cable

Table 3-15 Encoder cable type

Common encoder cable (ENCHG-LL-GA, ENCDG-LL-GA, ENCHG-(4)-GU-DC)	
<p>Cable specification: 1P 22AWG+ 2P 26AWG standard cable 22AWG corresponds to a cross-sectional area of 0.3247mm² 26AWG corresponds to a cross-sectional area of 0.1281mm²</p>  <p>Three rows of 15PINDB male Plastic case Driver end</p>	
<p>Cable specification: 1P 22AWG+ 2P 26AWG standard cable 22AWG corresponds to a cross-sectional area of 0.3247mm² 26AWG corresponds to a cross-sectional area of 0.1281mm²</p>  <p>Front</p>	
<p>3×2×0.2mm²</p>  <p>Battery</p> <p>Three rows of 15PINDB male Plastic case Driver end</p>	
Flexible encoder cable (ENCHGF-LL-GA, ENCDGF-LL-GA)	
<p>Cable specification: 1P 22AWG+ 2P 26AWG Flexible drag chain cable 22AWG corresponds to a cross-sectional area of 0.3247mm² 26AWG corresponds to a cross-sectional area of 0.1281mm²</p>  <p>Three rows of 15PINDB male Plastic case Driver end</p>	

Cable specification: 1P 22AWG+ 2P 26AWG Flexible drag chain cable
 22AWG corresponds to a cross-sectional area of 0.3247mm²
 26AWG corresponds to a cross-sectional area of 0.1281mm²

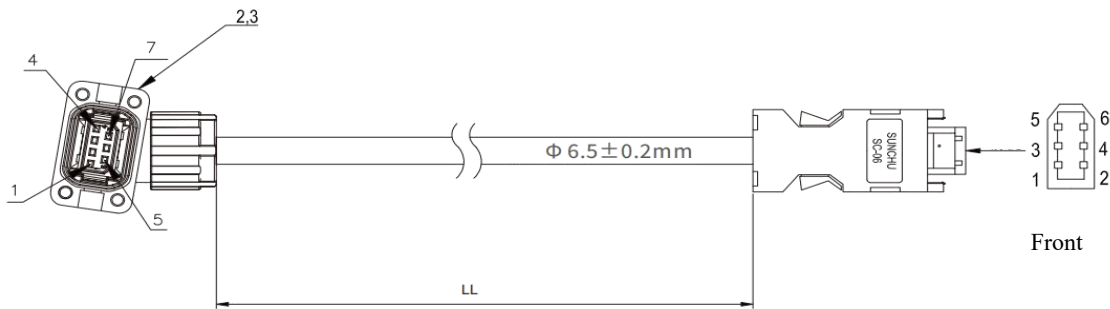


Table 3-16 Encoder cable port connection description

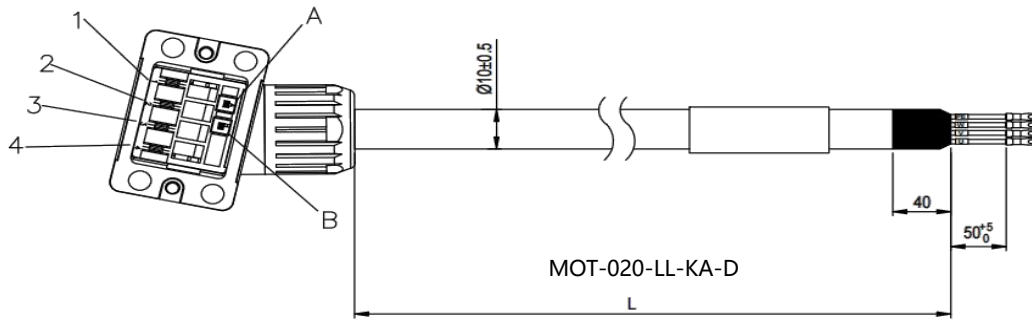
ENCHG/ENCHGF-LL-GA					
Motor end	Cable color	Signal			Driver end
PIN1	Red	VDD			PIN1
PIN2	Orange	GND			PIN2
PIN3	/	/			/
PIN4	/	/			/
PIN5	Blue	485+			PIN9
PIN6	Purple	485-			PIN14
PIN7	Shielded cable	Shielded			Shell
ENCDG/ENCDGF-LL-GA (Signal 1 for magnetoelectric encoders,Signal 2 for absolute encoders)					
Motor end	Cable color	Signal 1	Signal 2	Driver end	
PIN1	Red	VDD	GND	PIN1	
PIN2	Orange	GND	/	PIN2	
PIN3	Brown	MA_P+	/	PIN3	
PIN4	Black	MA_N	SD	PIN4	
PIN5	Blue	SLO_P+	/SD	PIN5	
PIN6	Purple	SLO_N-	Shielded	PIN6	
PIN7	Shielded cable	Shielded	GND	Shell	
ENCHG-(4)-GU-DC					
Motor end	Color	Black HSG	External single line	Signal	Driver end
PIN1	Red	/	/	+5V	PIN1
PIN2	Black	/	/	GND	PIN2
PIN3	Brown	PIN1	Red	BAT+	/
PIN4	Blue	PIN2	Black	BAT-	/
PIN5	Yellow	/	/	SD	PIN9
PIN6	Green	/	/	/SD	PIN14
Outer shell	Shielded cable	/	/	Shielded	Shell

2. Power cable

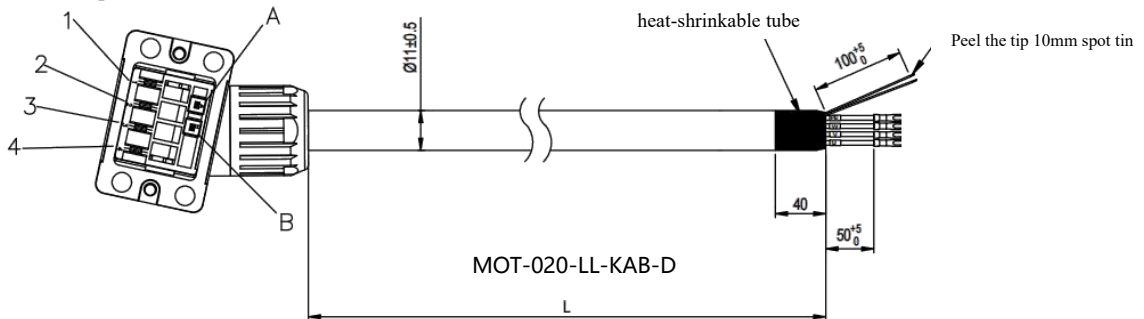
Table 3-17 Power cable types

Standard power cable	
<p>Cable specification: 4C*20AWG 300V Standard cable 20AWG corresponds to a cross-sectional area of 0.5189mm²</p>	
<p>Cable specification: 4C*18AWG+1P*24AWG Standard cable 18AWG corresponds to a cross-sectional area of 0.8107mm² 24AWG corresponds to a cross-sectional area of 0.2047mm²</p>	
<p>Cable specification: 4C*16AWG 300V Standard cable 16AWG corresponds to a cross-sectional area of 1.318mm²</p>	
<p>Cable specification: 4C*16AWG+1P*24AWG Standard cable 16AWG corresponds to a cross-sectional area of 1.318mm² 24AWG corresponds to a cross-sectional area of 0.2047mm²</p>	

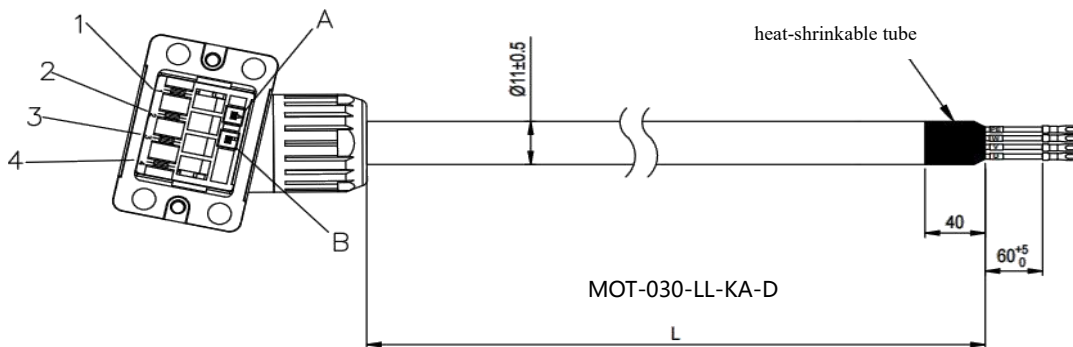
Cable specification: UL2586 4x13AWG Standard cable
 13AWG corresponds to a cross-sectional area of 2.627mm²



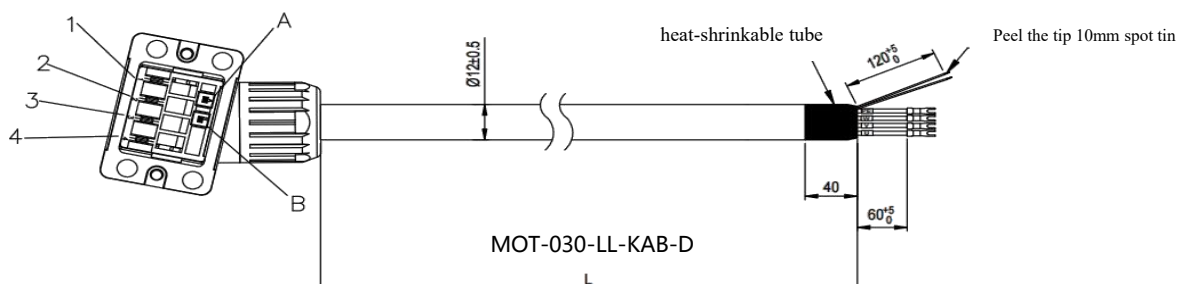
Cable specification: UL2586 4Cx13AWG+1Px20AWG Standard cable
 13AWG corresponds to a cross-sectional area of 2.627mm²
 20AWG corresponds to a cross-sectional area of 0.5189mm²



Cable specification: UL2586 4x12AWG Standard cable
 12AWG corresponds to a cross-sectional area of 3.332mm²



Cable specification: UL2586 4Cx12AWG+1Px20AWG Standard cable
 12AWG corresponds to a cross-sectional area of 3.332mm²
 20AWG corresponds to a cross-sectional area of 0.5189mm²

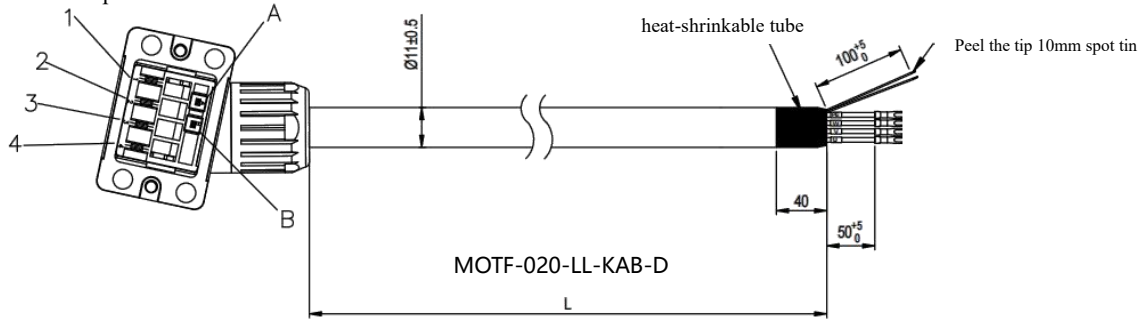


Flexible power cable	
<p>Cable specification: 4C×20AWG 300V Flexible drag chain cable 20AWG corresponds to a cross-sectional area of 0.5189 mm²</p>	<p style="text-align: center;">MOTF-005-LL-KA-D</p>
<p>Cable specification: 4C×18AWG+1P×24AWG Flexible drag chain cable 18AWG corresponds to a cross-sectional area of 0.8107 mm² 24AWG corresponds to a cross-sectional area of 0.2047mm²</p>	<p style="text-align: center;">MOTF-005-LL-KAB-D</p>
<p>Cable specification: 4C×16AWG 300V Flexible drag chain cable 16AWG corresponds to a cross-sectional area of 1.318 mm²</p>	<p style="text-align: center;">MOTF-011-LL-KA-D</p>
<p>Cable specification: 4C×16AWG+1P×24AWG Flexible drag chain cable 18AWG corresponds to a cross-sectional area of 1.318 mm² 24AWG corresponds to a cross-sectional area of 0.2047mm²</p>	<p style="text-align: center;">MOTF-011-LL-KAB-D</p>
<p>Cable specification: UL2586 4x13AWG Flexible drag chain cable 13AWG corresponds to a cross-sectional area of 2.627mm²</p>	<p style="text-align: center;">MOTF-020-LL-KA-D</p>

Cable specification: UL2586 4Cx13AWG+1Px20AWG Flexible drag chain cable

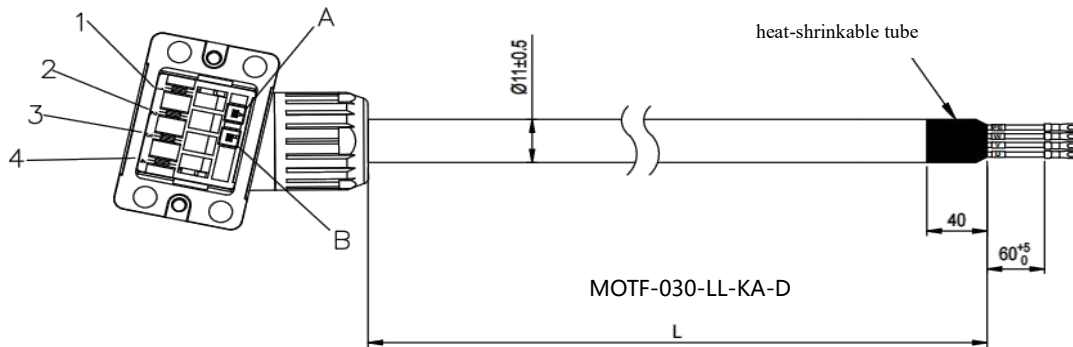
13AWG corresponds to a cross-sectional area of 2.627mm²

20AWG corresponds to a cross-sectional area of 0.5189mm²



Cable specification: UL2586 4x12AWG Flexible drag chain cable

12AWG corresponds to a cross-sectional area of 3.332mm²



Cable specification: UL2586 4Cx12AWG+1Px20AWG Flexible drag chain cable

12AWG corresponds to a cross-sectional area of 3.332mm²

20AWG corresponds to a cross-sectional area of 0.5189mm²

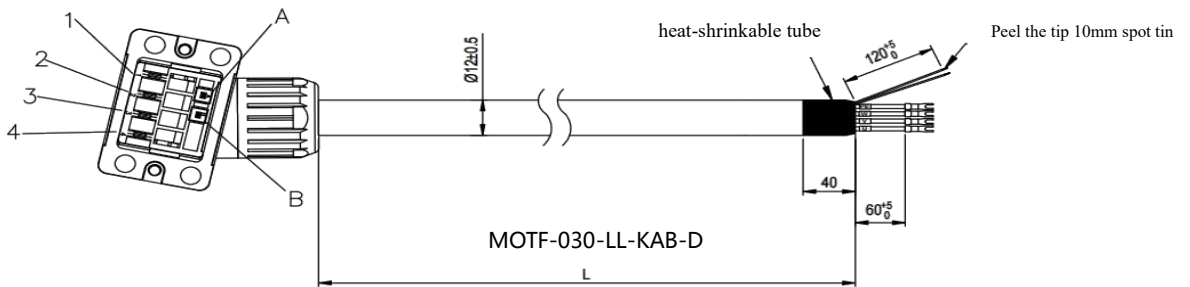
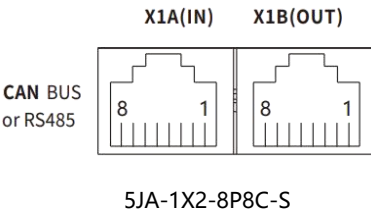


Table 3-18 Power cable port wiring description

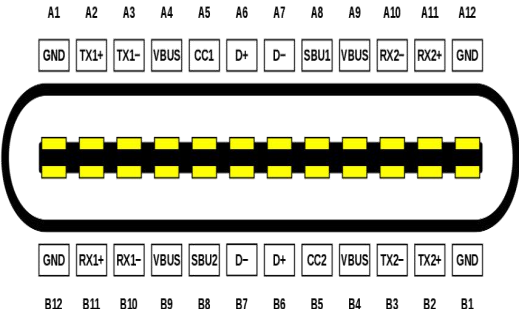
Pin	Cable color	Signal
PIN1	White	U
PIN2	Black	W
PIN3	Red	V
PIN4	Yellow and green+shielded	PE
PINA	Brown	Brake+ (with brake)
PINB	Blue	Brake- (with brake)

3.2.4 Driver Interface Terminal Description

3.2.4.1 Bus Communication Interface (X1)

	Pin	RS485/Modbus	CAN	EtherCAT
	1	-	CAN_H	TD+
	2	-	CAN_L	TD-
	3	-	GND_CAN	RD+
	4	485B	-	-
	5	485A	-	-
	6	-	-	RD-
	7	-	-	-

3.2.4.2 Communication Debugging Interface (X2)

	Pin	Signal
	A1&B12	GND
	A6&B6	USBDP
	A7&B7	USBDN
	A4&B9	+5V

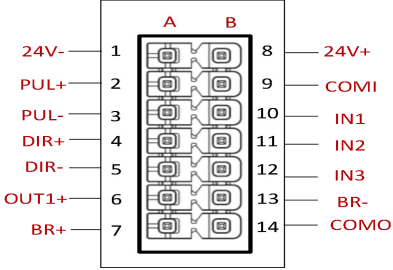


Note

- FD1X5 series driver use the Type-C communication interface to connect and debug the PC end. Users can buy the charging cable of the fast charging Type-C connector online. It should be noted that some cables may have GND and PE short connection, which will affect the communication stability. You need to use the usb isolator cable to connect the two ends. The isolator cable purchase link is as follows:

https://m.tb.cn/h.gcovkrNnIaapcxJ?sm=244100?tk=QSa3Wgq8vF3_CZ3458

3.2.4.3 Digital Signal Input/Output Interface (X3)

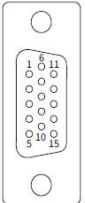
		Pin	Pin name	Pin specification
 <p>F8CR-THR-3.5-14P-A-L28</p>	8	24V+	The logical power input is positive Input voltage: 24V, rated input current: 1A	
	1	24V-	The logical power input is negative Input voltage: 24V, rated input current: 1A	
	2	PUL+	Pulse input function is only available for FD1X5-AB-000 Input voltage: 3.3V~24V Maximum input frequency:500KHz	
	3	PUL -		
	4	DIR+		
	5	DIR-	Digital signal output OUT1 is an open-collector output with a maximum voltage of 30V and a driving capacity of 100mA	
	6	OUT1+		
	14	COMO		Output common terminal
	7	BR+	Lock gate output positive end The output current of the lock port is 500mA	
	13	BR-	Lock output negative end The output current of the lock port is 500mA	
	9	COMI	Input common terminal	
	10	IN1	Digital signal input High level: 12.5-30VDC; Low level: 0-5VDC; Maximum frequency: 1KHz; Input impedance: 5KΩ.	
	11	IN2		
	12	IN3		



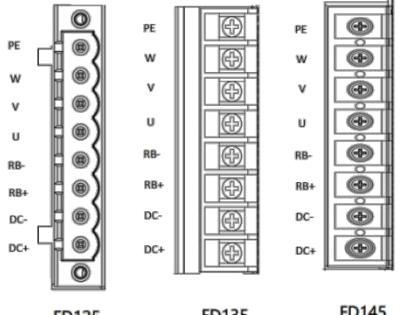
Note

- FD1X5 series drives do not support dual pulse mode!

3.2.4.4 Encoder Interface (X4)

		Pin	Magnetolectric photoelectric encoder signal (Supporting the Tamagawa Agreement)	Pin specification
 <p>15PIN DB Female</p>	1	+5V	5V supply voltage	
	2	GND	Encoder signal ground terminal	
	3	PTC_IN	Motor temperature detection	
	9	ENC_A	Encoder signal input	
	14	ENC_B		

3.2.4.5 Power and Motor Ports (X5)

		Pin	Pin specification
	PE	Servo motor power supply output end and motor grounding end	
	W		
	V		
	U		
	RB-		
	RB+	External brake resistance input	
	DC-		
	DC+	Drive power input	

X5 Interface terminal model:

FD125: F8A-8-5.0-08P-A FD135: BRTB950-02-08-R3 FD145: BRTB130-00-08-50A

X5 Interface terminal size

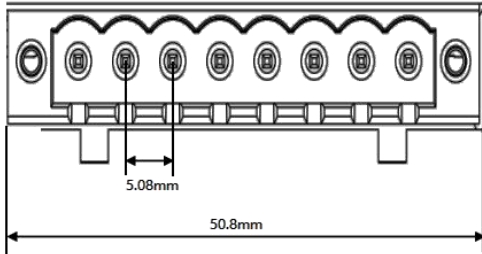
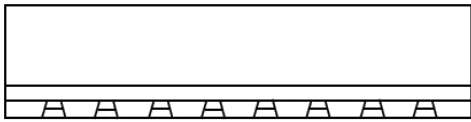


Figure 3-7 FD125 driver X5 interface dimension

Screw: M3.5 nickel-plated

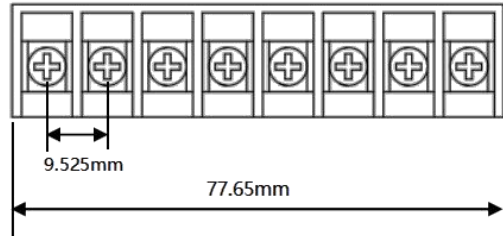
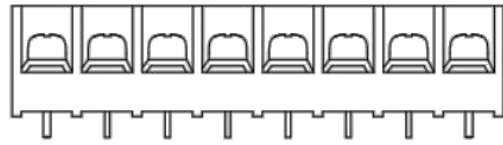


Figure 3-8 FD135 driver X5 interface dimension

Screw: M4 nickel-plated

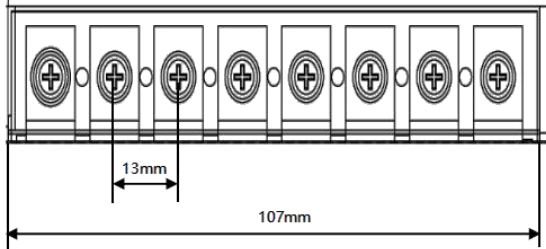


Figure 3-9 FD145 driver X5 interface dimension



Note

- The X5 interface of the FD125 drive needs to be connected to a terminal block before it can be used. The terminal model is F6AM-5.08-08P-1-A, and the screw tightening torque is 0.5 N.m ~ 0.6 N.m
- The maximum screw tightening torque for the X5 interface terminal of FD135 drive is 10 N.m; The maximum screw tightening torque for the X5 interface terminal of FD145 drive is 13 N.m

3.2.5 Driver electrical wiring

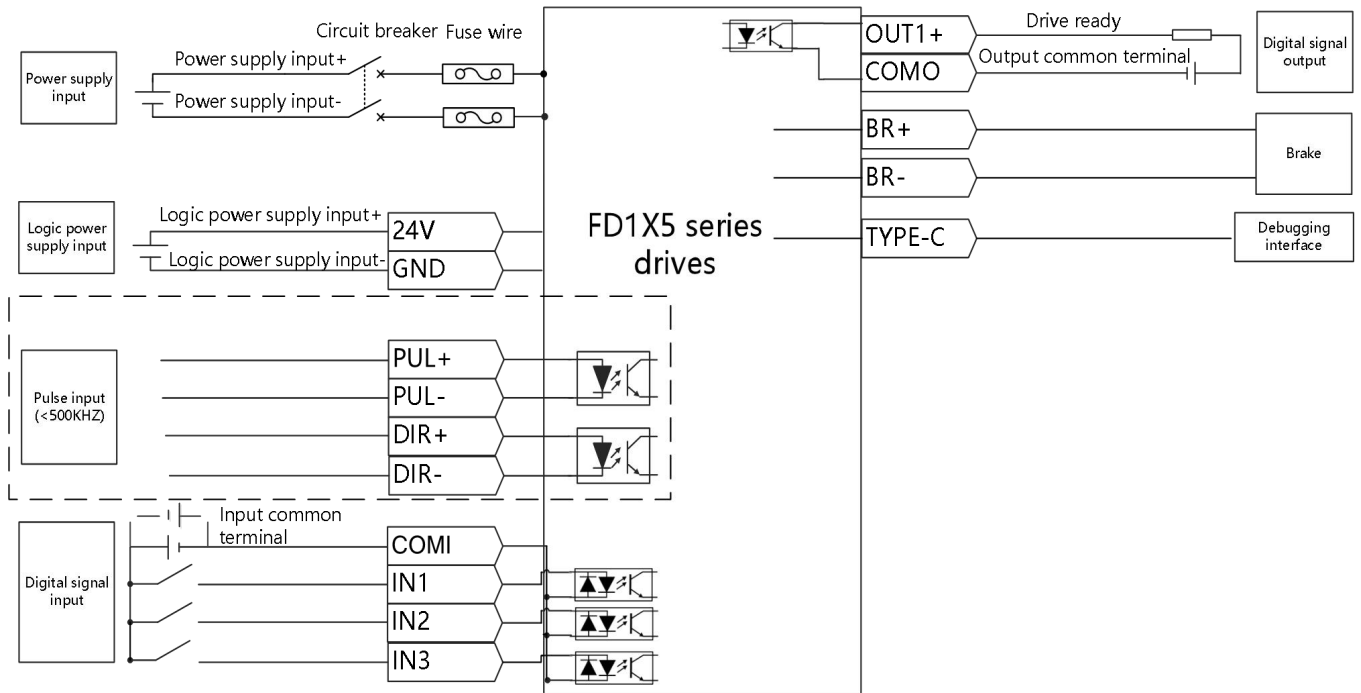


Figure 3-10 FD1X5 series drivers electrical wiring diagram



Note

- Figure 3-10 shows the wiring of the FD1X5 series driver with the default IO function. More IO functions can be defined by the upper computer software.
- For the digital input and output signals, the wiring mode with the host computer is shown in the following table.

Table3-19 Example of digital input and output signal wiring

Digital signal input wiring	
Description	Digital input port high level input voltage range: 12.5-30VDC; Low input voltage range: 0-5VDC; Maximum input frequency: 1KHz
The upper computer is relay output	
The upper computer is open collector output	<p style="text-align: right;">NPN</p>
	<p style="text-align: right;">PNP</p>

Digital signal output wiring	
Description	The OUT1 drive capacity is 100mA, and the lock output (OUT5+/OUT5-) capacity is 500mA, which can directly drive the lock device
The upper computer is relay input	
The upper computer is optocoupler input	

3.2.6 Brake connection

3.2.6.1 Internal brake connection

Table 3-20 Example of brake wiring

Description	1.By default, pin 7 and pin 13 of the driver IO terminal are the output signals of the motor brake, which can be directly driven by OUT5 through the upper computer simulation 2.Thebrake coil of the motor has no polarity and is not positive or negative
Example of brake connection	



Note

- The motor brake does not need external 24V power supply. You can simulate the OUT5 drive lock device by connecting to the host computer. For details, see **section 5.7.2**.
- When the connected brake motor is a magnetolectric encoder, the connection of the brake needs to distinguish positive and negative polarity to avoid the impact of wrong polarity on the accuracy of the motor encoder (brown positive electrode, blue negative electrode).

3.3 External installation instructions

Table 3-21 External system installation description

Electrical equipment	Effect
MCCB	When there is overcurrent, short circuit or undervoltage, the circuit breaker automatically cuts off the power supply, thereby protecting the line and driver equipment from damage. Note that the circuit breaker matching the driver should be selected to effectively protect the drive device. To prevent accidental electric shock, please use circuit breakers with overload protection, short circuit protection and leakage protection.
NF	Effectively filter out the external interference, improve the anti-interference ability of the power supply circuit.
MC	The use of air type AC electromagnetic contactor is used to switch off the power supply, while installing the electromagnetic contactor manufacturer recommended surge suppressor can effectively prevent reverse electromotive force.
CHARGE	Charging indicator light, due to the charging capacitor in the internal circuit of the driver, the charging indicator light will not be extinguished immediately after the power is cut off. Make sure that the charging indicator is off or the measured DC bus voltage of the driver is lower than 36V before touching the power terminal.

Table 3-22 Recommended circuit breaker model

Servo driver model	Recommended circuit breaker		
	Model	Specification	Manufacture factory
FD1X5 series	NB1G-63	AC230V,63A	CHNT
iSMK series	NXB-63 D32	AC230V,32A	

Table 3-23 Recommended noise filter model

Servo driver model	Recommended noise filter			
	Model	Specification	Manufacture factory	
FD1X5 series	FD125	TY440S-16FT	Single phase direct/AC 120/250VAC, 16A	Tyze
	FD135	QMN30M4-S	Single phase DC/AC 120/250VAC, 30A	QIMAI
	FD145	QMN50M4-S	Single phase DC/AC 120/250VAC, 50A	QIMAI
iSMK series	iSMK60	TY440S-16FT	Single phase DC/AC 120/250VAC, 16A	Tyze
	iSMK80	Built-in filter board	/	/

Table 3-24 Recommended contactor model

Servo driver model	Recommended contactor			Note
	Contactor model	Specification	Manufacture factory	
FD1X5 series	TGC1-6511	AC220V,65A	TENGEN	The user chooses the working voltage of the contactor coil according to the field use
iSMK series	NXC-25	AC220V,25A	CHNT	

Table 3-25 Recommended fuse

Servo driver model	Recommended fuse			
	Specification	Rated current (A)	Manufacture factory	
FD1X5 series	FD125	ANL35A80VDCM8	35	Vicfuse
	FD135	ANL60A80VDCM8	60	
	FD145	ANL150A80VDCM8	150	
iSMK series	iSMK40	ATU10A80VDCM8	10	
	iSMK60	ANL35A80VDCM8	35	
	iSMK80	ANL60A80VDCM8	60	



Warning

- A surge suppressor is installed on the coil of the relay and electromagnetic contactor to prevent the damage caused by the peak voltage to the equipment.
- For details about the driver external brake resistance configuration, see **3.2.2.1**.
- Do not connect the power cable to the UVW end, and do not connect the external brake resistor to the DC+ and DC- ends. Before powering on the driver, check whether the cable connections are correct.
- High voltage may remain in the drive after power off. Please check that the CHARGE indicator is off ten minutes after power off before disassembling and repairing the drive.
- Please do not share power with welding machines, lasers and other equipment;

3.4 EMC Configuration Description

FD1X5 and iSMK series servo drives meet the relevant requirements of EMC certification standards EN 61800-3, EN61000-6-2, EN61000-6-4 and so on under the set conditions, but in the course of product use, it may be affected by the actual installation method, connector and wiring status. Results in different EMC test levels..



Warning

- In the civil environment, this product may cause interference which may degrade the reception quality of radio signals. Users shall take suppression measures if necessary to prevent interference.
- Products must be installed and certified by professionals who are familiar with safety and EMC requirements, and EMC engineers are responsible for ensuring that the products and systems produced comply with relevant laws.

Site condition

iSMK and FD1X5 devices are not directly connected to the mains and meet the requirements of OVC II and PD II use sites.

Installing environmental condition

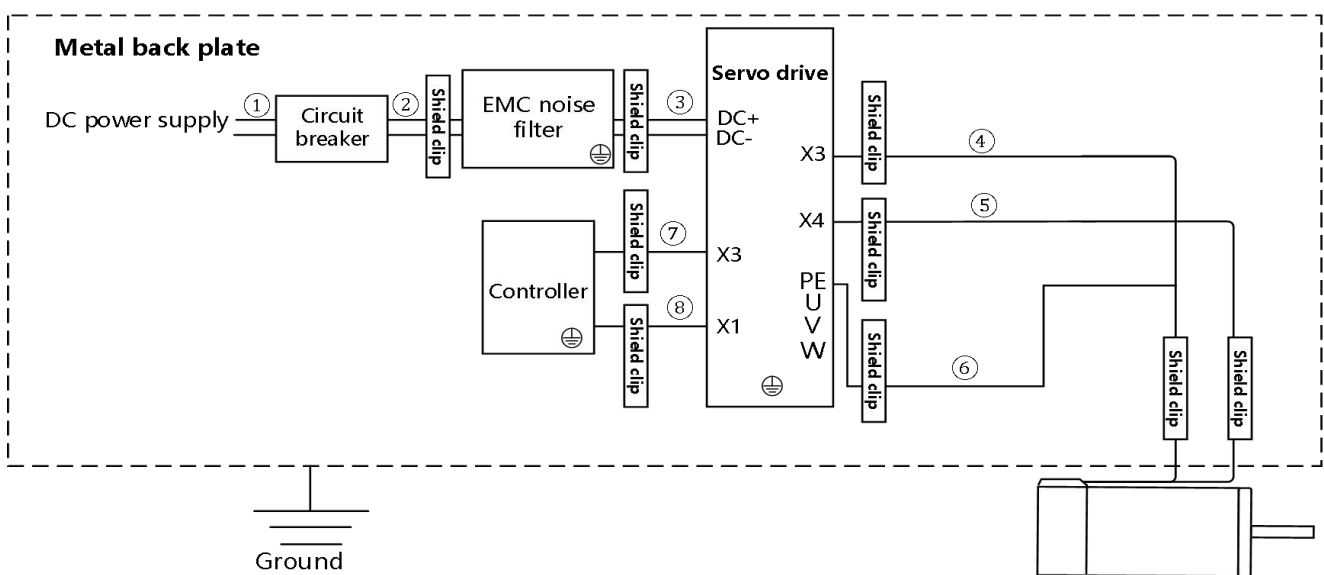


Figure 3-11 FD1X5 series driver installation environment diagram

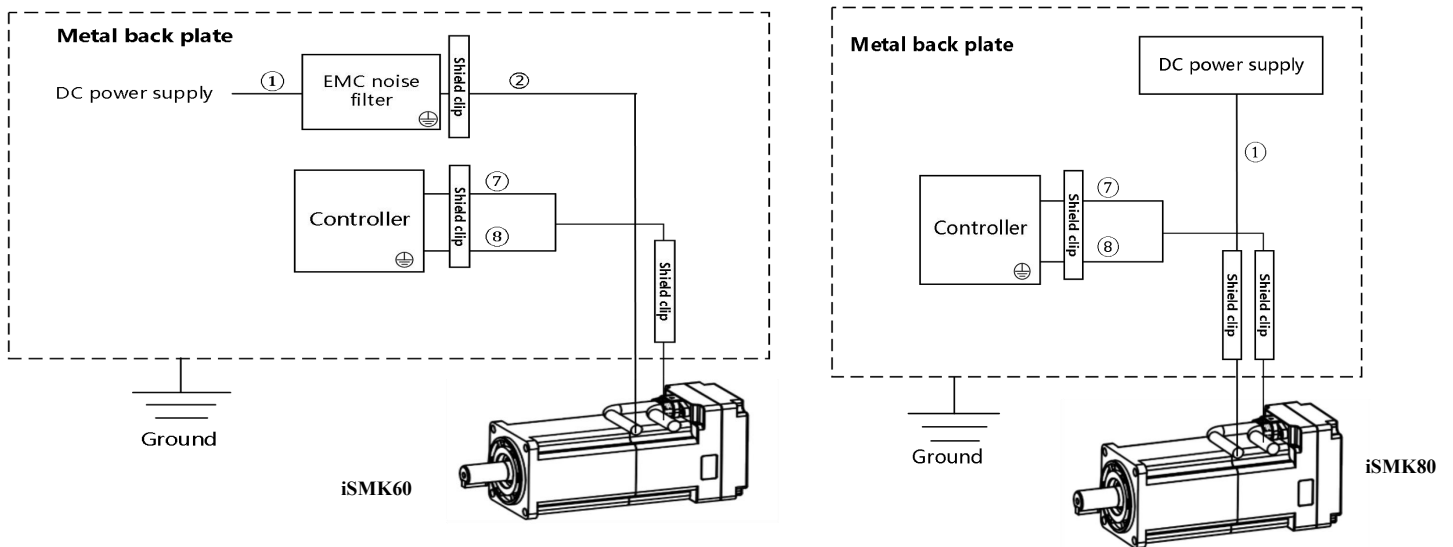


Figure 3-12 iSMK series driver installation environment diagram



Note :

1. Select the shielded cables in the diagram with a shielding coverage rate of more than 85%.

Serial number	Cable name	Specification
①②③	Power cable	Shielded cable
④	Brake cable	Shielded cable
⑤	Encoder cable	Shielded cable
⑥	Power cable	Shielded cable
⑦	Input/Output signal cable	Shielded cable
⑧	Communication cable	Shielded + twisted pair cable

2. Please install the device in the control cabinet. The device should be installed on the same metal backplane with good electrical conductivity in the cabinet.

(1) EMC noise filter

- To ensure compliance with EMC standards, install an EMC noise filter at the power input close to the servo drive. For the noise filter model, see **Section 3.3**.
- The length of the cable between the output of the noise filter and the input power supply of the driver should be less than 30cm;
- The driver and filter are installed in the same metal backplane and the metal backplane is well grounded;
- Do not lay the input and output cables of the filter in the same slot or bind them together.
- The PE of the filter and the PE of the driver are single-point grounded, and it is forbidden to connect PE in series to the ground pile.

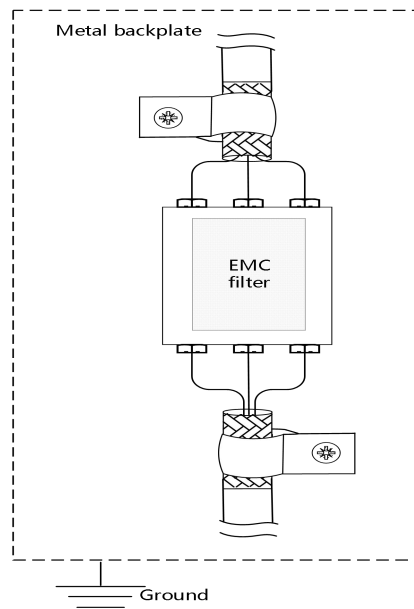


Figure 3-13 EMC noise filter installation diagram

(2) Shielded layer

- Input and output signal cables, power cables, encoder cables and communication cables please use shielded cables.
- The shield of the encoder is clamped to the connector metal housing using metal cables.
- The shielding layer near the driver side of the power cable is locked to the driver PE screw using the U-shaped metal clip delivered with the product.
- If the power line and the encoder are not direct outlet solutions, it is necessary to peel the sheath layer at both ends of the connector and connect the shielded layer of the cable to the metal plate using a 360-degree shield clamp.

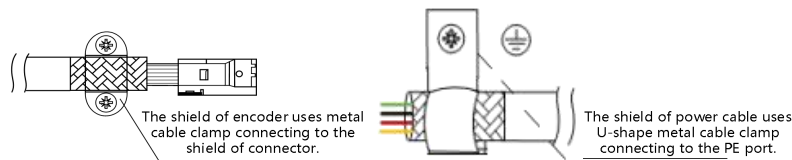


Figure 3-14 FD1X5 driver side power line/encoder line shield layer 1* processing mode

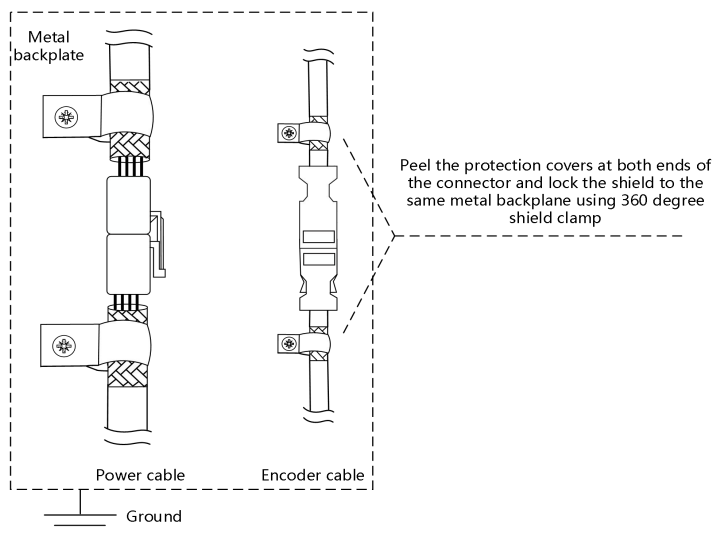


Figure 3-15 FD1X5 connector side power line/encoder line shield layer 2* processing method

(3) Grounding

- In order to prevent electric shock, be sure to ground the reactor, noise filter, driver;
- When multiple servo drivers are used, do not connect the ground cables of multiple servo drivers in series. Instead, use the single-point grounding method.
- The driver should be grounded with the shortest possible cable ($>2\text{mm}^2$). If the ground cable is longer, increase the diameter of the ground cable ($\geq 4\text{mm}^2$).

(4) Magnetic ring

- When the driver and motor are used for wiring and grounding problems, mutual interference with other devices may still occur. In this case, a magnetic ring can be placed on the cable to effectively inhibit interference.
- The preferred choice of ferrite magnetic ring, can suppress higher frequency interference above 1M, the power line is recommended to add RFC-13 magnetic ring (around 2-3 turns), the encoder line and other I/O signal line is recommended to add RFC-10 magnetic ring (around 2-3 turns), the magnetic ring installation position as close as possible to the driver side, the magnetic ring installation distance on the cable should be less than 300mm. The installation diagram is as follows:

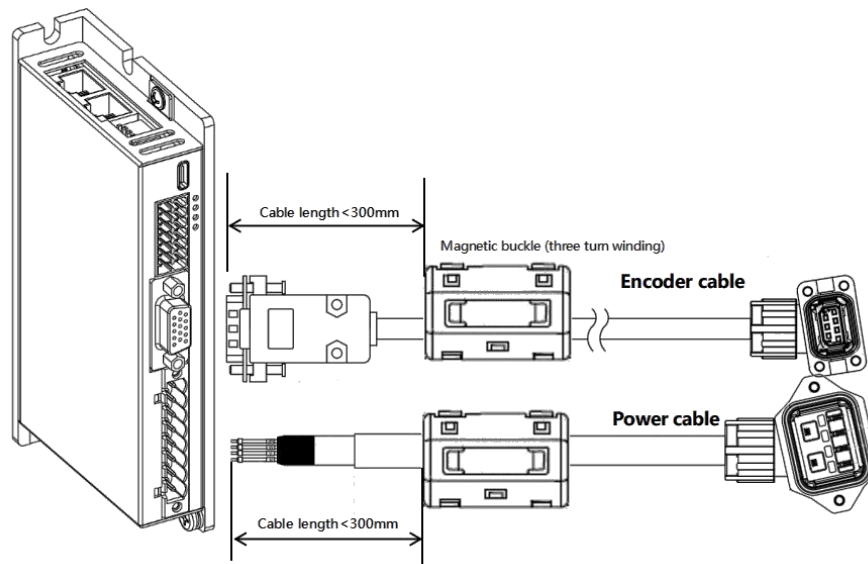


Figure 3-16 Magnetic ring installation diagram

3.5 Servo overload protection feature

The driver calculates the heat by the output current, and implements the overload protection function for the driver and the motor. Overload protection means that when the driver and motor exceed the rated current, continuous use cannot be guaranteed, and only overload operation can be carried out under the overload protection characteristics.

Because the driver and the motor work at the same time, if the load rate of the motor reaches 100% first, the overload alarm protects the motor; When the load rate of the driver reaches 100% before the motor, the overload alarm protects the driver.

FD1X5 has no temperature sensor for overheating protection, can not real-time monitoring of the actual temperature of the motor, if there are special conditions need to detect the real-time temperature of the motor, please consult our sales staff.

iSMK series integrated machine contains a motor temperature sensor for overheating protection, which can monitor the actual temperature of the motor in real time, but cannot meet the impact of instantaneous temperature on the motor, and still need to use the motor IIT for protection.

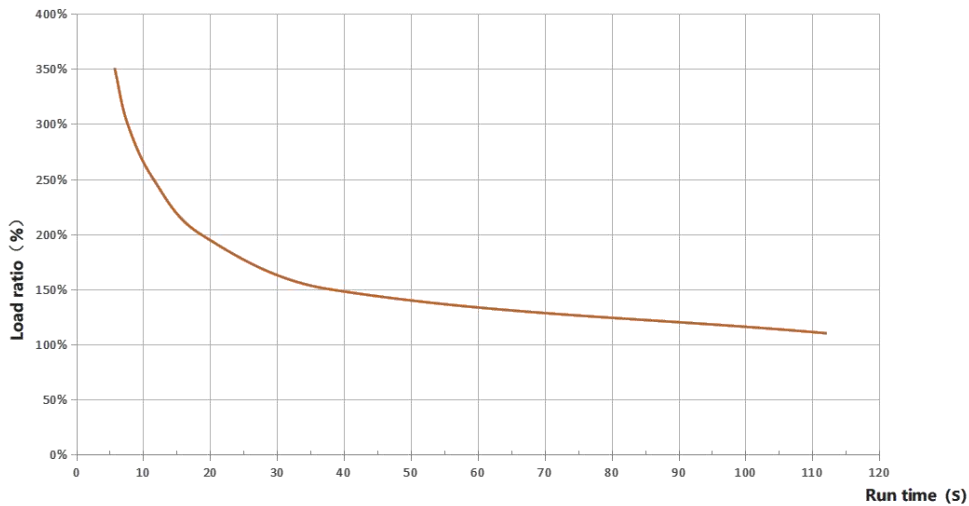


Figure 3-17 iSMK overload characteristic curve



Note

- The overload characteristic curve shown in Figure 3-17 applies to all iSMK series models.
- After the driver or motor IIT failure (fault code: 080.0), driver output short circuit (fault code: 008.0), driver bus voltage is too high (fault code: 002.0) and other alarms, stop the fault first, check the cause of the fault, and then try to run. If the root cause of the fault is not identified, a high-frequency reset may cause damage to the drive hardware.

Name	CANopen	Modbus	Type	Data type	Explanation
Motor IIT actual utilization	2FF01010	2A00	RL	Unsigned8	The actual load rate of the motor
Actual drive IIT utilization	2FF01110	2A01	RL	Unsigned8	The actual load rate of the drive
Motor temperature alarm point	64101810	7180	RWSL	Integer16	The default alarm point for the temperature is 100 °C
Current motor temperature	64101910	7190	RLT	Integer16	Display the temperature of the temperature sensor



Note

When the motor is not connected to the temperature sensor or the temperature sensor is abnormal, the motor temperature will be displayed at -40°C.

3.6 Power Supply Description

The iSMK and FD1X5 series drivers must use the monotonic power supply shown in Figure 3-18 when powering on. If the non-monotonic power supply shown in Figure 3-19 is used, when the deviation is close to any threshold voltage, the non-monotonic slope may cause problems such as abnormal start of the driver, resulting in an error failure.

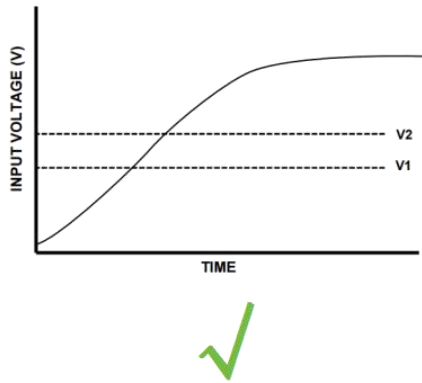


Figure 3-18 Monotonic power supply

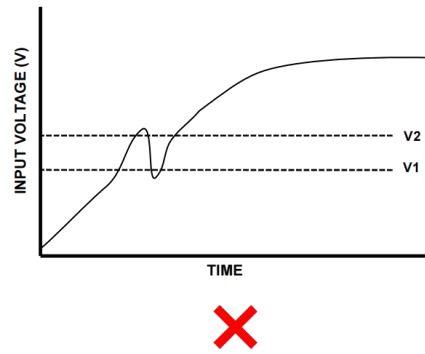


Figure 3-19 Non-monotonic power supply



Note

- In figure 3-18 and figure 3-19, V1 indicates 10V voltage, and V2 indicates 17V voltage.
- The driver has an electrolytic capacitor. Ensure that the input power is working properly before powering on the driver.

Chapter 4 Trial operation

4.1 KS3 debugging software description

4.1.1 Overview

The KincoServo3 software installation package can be obtained from kinco official website..

iSMK series drivers use KincoServo3 software to connect the PC to the servo driver through 485 port, and does not support USB communication.

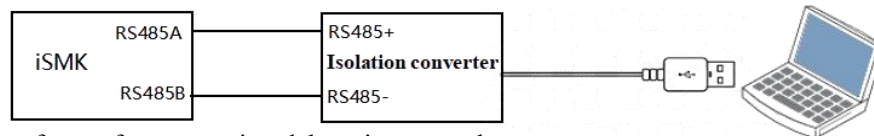
FD1X5 series drivers use KincoServo3 software to connect the computer to the servo drive through 485 port or USB.

4.1.2 Connection

4.1.2.1 Description of the connection between the PC and the drive

485 communication connection

- If user want to realize the communication between iSMK and PC, user need to purchase a 232/485 to USB isolation converter. The 485 communication connection method is as follows:

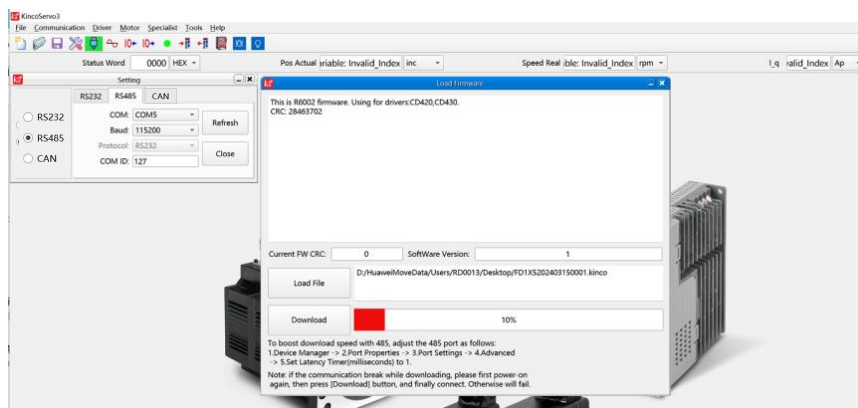


When using the software for connection debugging, note that:

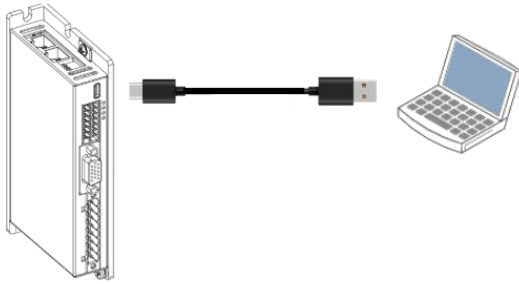
- Select the RS485 port on the Setting . The default communication protocol of the 485 port on the iSMK is 232. Therefore, the host computer can be successfully connected without changing the communication protocol using the internal address.



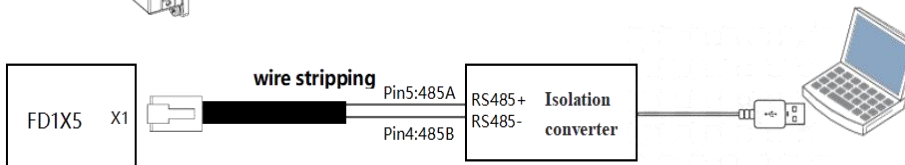
- If a sudden power failure causes communication interruption during firmware update using the RS485 port. The phenomenon displayed on the software is shown below. You need to power on the drive, click the download button to enable the serial port communication before updating the firmware again.



- FD1X5 driver communicates with the PC : Communicate using a USB-type C cable via the X2 port of the drive or via the X1 port with a 232/485 to USB isolation converter.



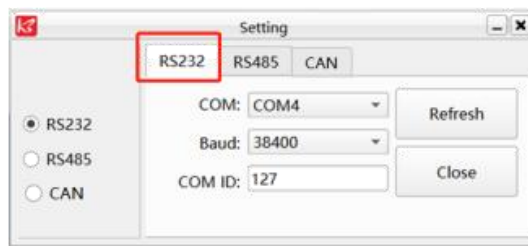
X2 interface communication



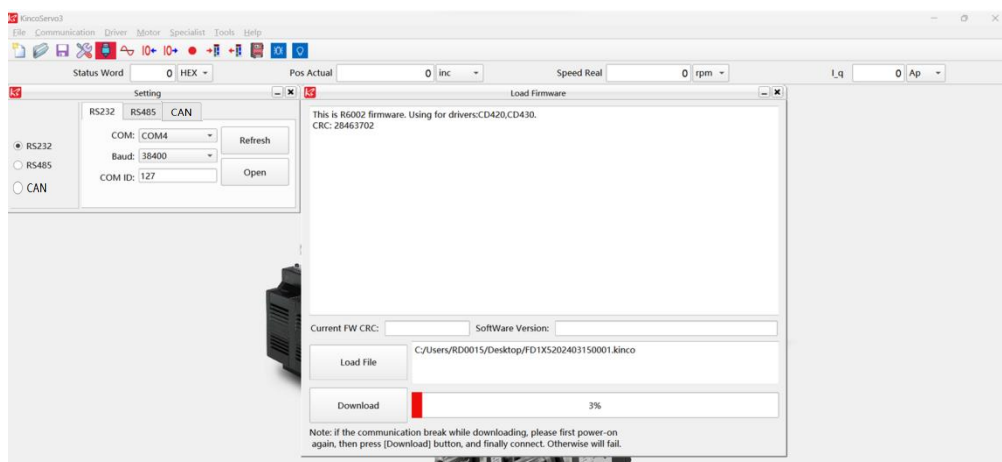
X1 interface communication

(1) When using the USB cable to connect to the host computer, note that:

- The RS232 interface is required on the communication settings page. Since the USB interface of the FD1X5 drive uses the 232 communication protocol by default, it can be successfully connected to the host computer without changing the communication protocol through the internal address.

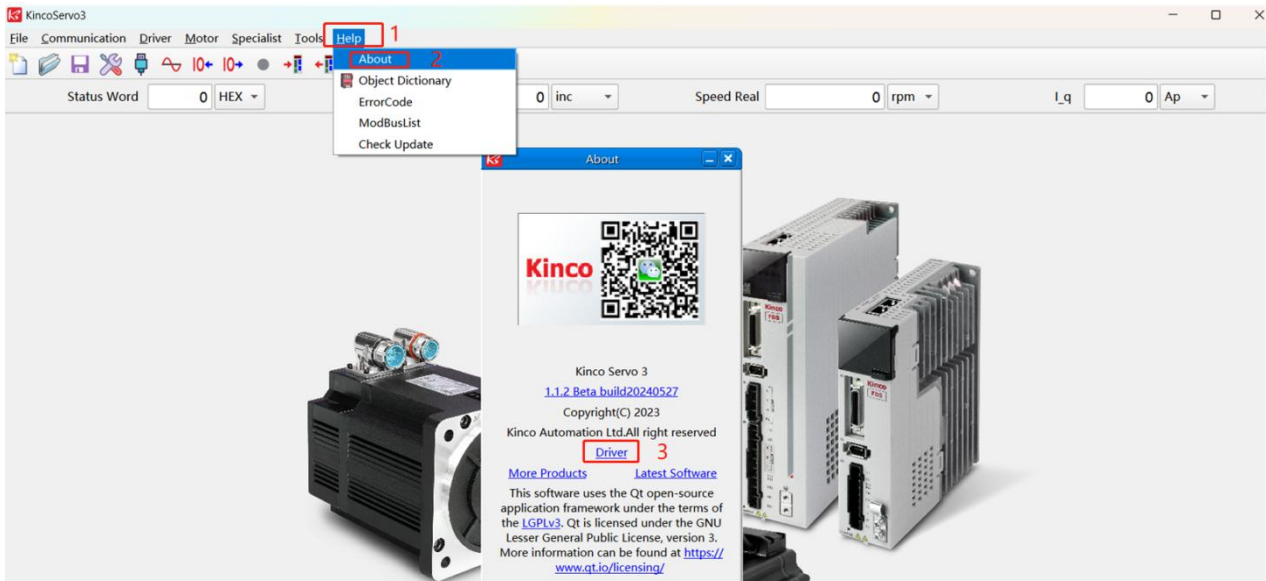


- If only the USB cable is used to communicate with the host computer and there is no power supply outside the drive, the debugging cable suddenly drops during data storage. In this case, the drive will report to EEPROM.
- When using the Type-C interface in the process of updating the firmware, the power suddenly fails, resulting in communication interruption, the phenomenon displayed on the software is as follows, You need to power on the drive, click the download button to enable the serial port communication before updating the firmware again.



- For most users who use XP/Win7/Win10/Win11, the Type-C interface does not require the user to install the driver. If the drive cannot connect to the upper computer after accessing the Type-C interface, the serial port driver used by the Type-C interface may be wrong. Here provides tested and

verified Type-C serial port driver, users can download from Baidu Netdisk. The operation is as follows: click "Help" → "About", click "Driver" button in the pop-up interface will jump to the corresponding Baidu Netdisk interface, select FD1X5 special serial port driver folder to download.



(2) When using X1 interface connect to the host computer, note that:

- The default communication protocol of the X1 interface of the FD1X5 driver is MODBUS. You need to change the RS485 communication protocol (modbus address mapping is 0X86C0) to 232 by modbus. Perform the following steps to restart the driver after the operation is complete.

Step	MODBUS message	Message specification (ID=1)
1	01 06 86 C0 00 01 61 7E	65100C Write 1 , switch to the 232 protocol immediately
	01 06 86 C0 00 03 E0 BF	65100C Write 3, switch to the 232 protocol, save the Settings, and take effect after restart
2	01 06 29 10 00 01 41 93	Storage control parameter

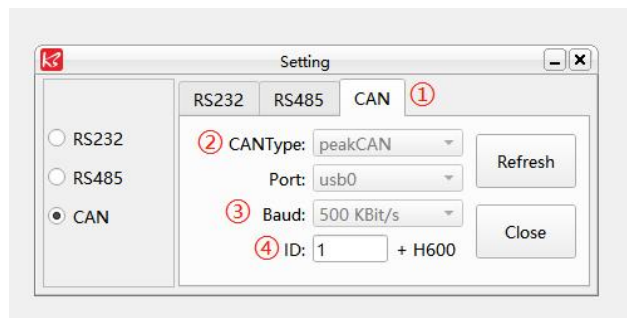
Relevant parameter:

Internal address	Parameter Name	Meaning	Default
100B0010	Equipment station number	Driver station number	1
2FE20010	RS485 baud rate	Set the baud rate of the RS485 port (Modbus address: 0X2600) Set value Baud rate 1080———9600 540———19200 270———38400 90———115200 Note: Need to save and restart.	iSMK:90 FD1X5:270
65100C08	RS485 Communication protocol selection	bit0: 0: Using MODBUS protocol 1: using RS232 communication protocol bit1: 0: Changing bit0 takes effect immediately 1: Changing bit0 takes effect when the storage restarts	iSMK: 1 FD1X5:0
65100E10	RS485 mode	Data bit =8, stop bit =1, no parity check	Fixed value

Note
Do not move the PC interface when downloading the firmware. Otherwise, the download will fail.

CANopen communication connection

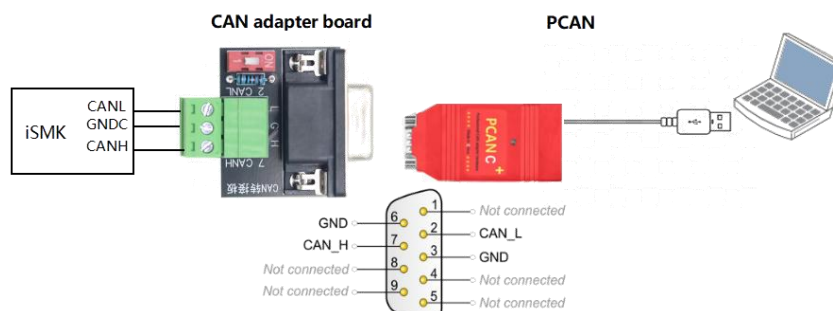
The iSMK and FD1X5 drive can also communicate with the host computer through the CANopen protocol. Since one CAN bus can mount multiple devices, this function realizes the cascaded debugging of multiple drives. The communication operation is as follows:

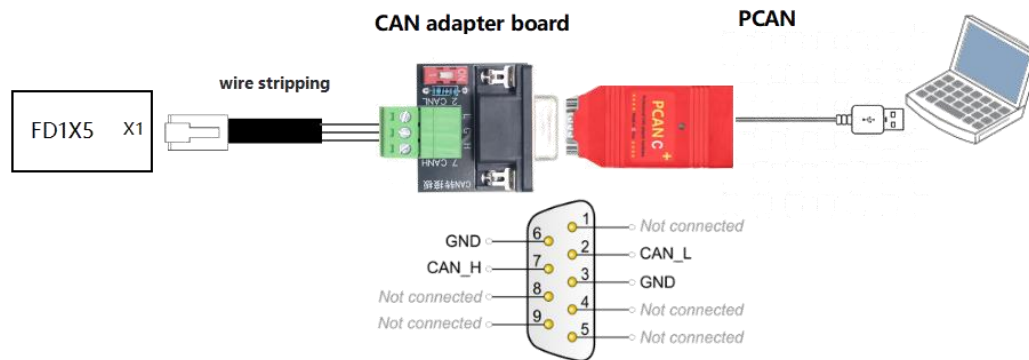


- (1) Switch to the CAN interface on the Setting page
- (2) Select the type of CAN device to be used. Currently, two kinds of CAN devices are supported to connect with the host software:

- **Peak CAN device** Recommended purchase link is as follows:
 - a. **【Amazon】**
https://www.amazon.com/CAN-Adapter-PCAN-USB-Isolation-GC-CAN-USB-ISO/dp/B078VQDR3G/ref=sr_1_1?crd=P0P8ZG4LDOON&dib=eyJ2IjojMSJ9.cnsyJZ7VFjmrXpKz0K3pvKcQeaNNnduR0GI3wMWP0uy8_IHbeGgFXk73ql-yfhIZl6j92rVCgMlCm1I7n-IDLb82DHgcDiTg8w0I2-w_-5hxsV2pi7y1yyoOm_f6NJ6_
- **ChuangxinCAN**

The connection between iSMK/FD1X5 driver and host computer to realize CAN communication are as follow:

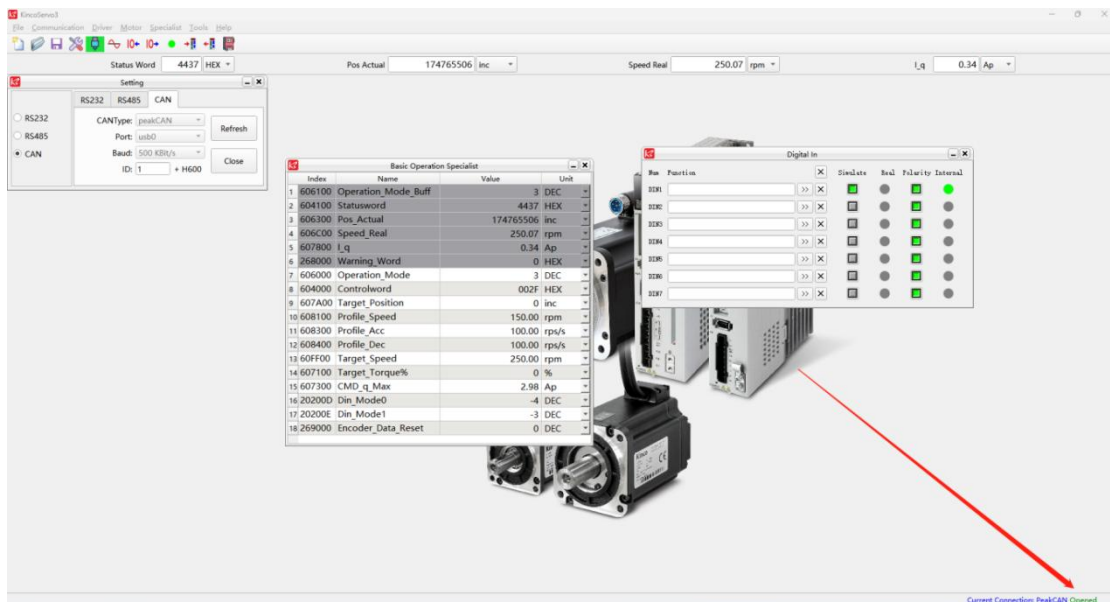




(3) Select the baud rate of CAN communication, the default is 500 KBit/s, and the object dictionary address is 【2F81 00】

(4) Select the device station number, the default is 1, the object dictionary address is 【100B 00】

After following the above steps, click the open button to connect the upper computer. Take the PeakCAN device as an example, the sign after successful connection of CAN communication is shown as follows:



Note

The following are several situations that may cause the communication failure of the upper computer:

- CAN Type is not set correctly. Currently, only Peak CAN and Chuangxin CAN can be connected to the upper computer
- The baud rate and device station number are not set correctly
- The driver of CAN device is not compatible, here provide tested and verified PeakCAN and Chuangxin drivers, users can download from Baidu Netdisk. The operation is as follows: click "**Help**" → "**About**", click "Driver" button in the pop-up interface will jump to the corresponding Baidu Netdisk interface
- The communication between KS3 and driver adopts CANopen protocol. Therefore, during the communication of the upper computer, do not use other devices (such as PLC or Linux devices) to send CAN messages (such as SDO/PDO messages) to the drive, otherwise the communication of the upper computer will be abnormal or even unable to communicate

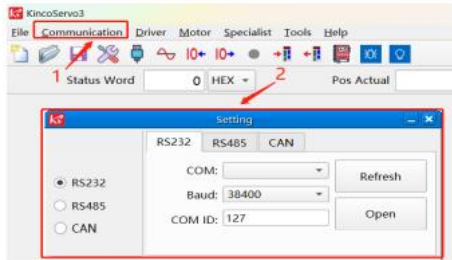
4.1.2.2 Start KincoServo3

1. Start kincoservo3

- Double click to launch the software



2. Click Communication to open the Setting



- Click Refresh, and select the serial port from the drop-down list.
- Select the baud rate set inside the drive. The default is 115200 for ismk and 38400 for FD1X5.
- Set the device station number of the drive. The default is usually 1 (127 is the universal ID).



Note

When the host computer and the driver are not connected, the following points should be noted:

- Determine the quality of the communication cable and check whether the communication connection is correct.
- Check whether the debugging cable is consistent with the serial port connected to the PC.
- Verify that the baud rate selected for communication is the value set internally by the drive.
- Determine whether the station number set for communication is the station number set inside the drive, you can use the universal ID=127 for connection.

4.1.3 Debugging Software Function Description

KincoServo3 has the following functions:

- **System monitoring:** monitor the running status of the servo drive, alarm, and detect and save the instantaneous data of the servo operation

Specific functional modules include:

- Oscilloscope function
- Alarm display function
- Status monitoring function

- **Parameter management:**

- Read and download all parameters in the servo drive object dictionary
- Read the previously saved parameter file
- Modify the parameter
- Send the parameter to the drive
- Save the drive parameter to EEPROM
- Restores factory parameter

- **Inertia recognition:** After a series of actions to identify the load inertia can be written to the driver through parameter management
- **Gain adjustment:**
 - The rigidity level and adjustment method of the servo can be adjusted. When adjusting to manual mode, each parameter can be modified
 - The rigidity level can be set. Its main function is to call the rigidity table. Different rigidity levels correspond to the corresponding PID parameters in the rigidity table, and no parameter can be modified

4.2 Pre-operation preparation

The following table items need to be checked before running the drive and servo motor.

4.2.1 Cable Connection and environment Check

Table 4-1 Check list

Serial number	Wiring check items
1	The power input terminals (DC+, DC-) of the servo driver must be properly connected
2	The servo driver output terminals (U, V, and W) and the servo motor power cables (U, V, and W) must be in the same phase and connected correctly.
3	The power input terminals (DC+, DC-) and main loop output terminals (U, V, W) of the servo driver cannot be short-circuited
4	The control signal cables of the servo driver are correctly connected, and the external signal cables such as lock and over-range protection are reliably connected
5	The servo drive and servo motor must be reliably grounded
6	The stress on all cables is within the specified range
7	The distribution terminals have been insulated
Serial number	Environmental inspection items
1	There are no foreign objects such as wire heads and metal shavings inside and outside the servo drive that will cause short circuit of signal lines and power lines
2	The servo drive and external brake resistors are not placed on combustible objects
3	The installation, shaft and mechanical connection of the servo motor must be reliable
4	The servo motor and the connected machinery must be in operational condition

4.2.2 Motor parameter check

iSMK series is an integrated drive, so there is no need to change the motor parameters; FD1X5 series currently only supports the encoder motor of the Tameragawa protocol, and the relevant parameters can be modified according to the motor parameter table when configuring the motor parameters.

Relevant parameter:

Internal Address	Bits	Parameter name	Meaning description
3041.06	Unsigned8	Use the internal motor library	1: The user enters the motor model manually and uses the motor parameters corresponding to the motor library in the driver 2: Read and use the motor parameters saved in the encoder

6410.01	Unsigned16	Motor model	Motor model	Corresponding code (Motor code)
			SMK60S-0020-30SAK/SBK-5DSA	R2
			SMK60S-0040-30SAK/SBK-5DSA	R4
			SMK80S-0075-30SAK/SBK-5DKA	R7
			SMK80S-0100-30SAK/SBK-5DKA	R8
			Note: The above models are SMK single-turn motors, which can be set up using internal motor library 1/ internal motor library 2	
			Motor model	Corresponding code (Motor code)
			SMK60S-0020-30QAK/QBK-5DSA	R2
			SMK60S-0040-30QAK/QBK-5DSA	R4
			SMK80S-0075-30QAK/QBK-5DKA	R7
			SMK80S-0100-30QAK/QBK-5DKA	R8
			Note: The above models are SMK multi-turn motors which corresponding motor code remains unchanged, and it must be set up using internal motor library 2	

**Note**

Please refer to **Section 5.7.5** for more details on motor parameter configuration steps

4.3 Trial operation

In order to verify whether the servo drive and motor can be used normally, the -3 mode can be used to confirm whether the servo motor can rotate normally, and observe whether there is abnormal vibration and abnormal sound during rotation. It can be connected to the upper computer software for operation. Its operation steps are as follows:

- Wiring check:
 - Power input and motor output are correctly connected
 - 485 debugging cable (or USB debugging cable) is used to communicate with the servo drive and the upper computer software KS3
- Check whether the POWER supply voltage is within the rated range. Power on the driver and observe whether the power indicator is steady on
- Configure the enable signal and set the working mode to -3. During the initial operation, it is recommended to rotate the motor at a low speed to confirm whether the motor is rotating correctly
- Observe the motor rotation direction is correct, if the motor steering is found to be opposite to the expected, please check the input command signal, command direction setting signal
- The running state can be monitored in the upper computer software, such as actual speed, actual current and other parameters
- After the above motor condition check is completed, the PID related parameters can be adjusted to make the motor work in the expected condition

**Note**

If a drive alarm occurs during the trial operation, refer to **Chapter 10** for error troubleshooting

Chapter 5 Working mode introduction

The servo system consists of three main parts: servo drive, servo motor and encoder.

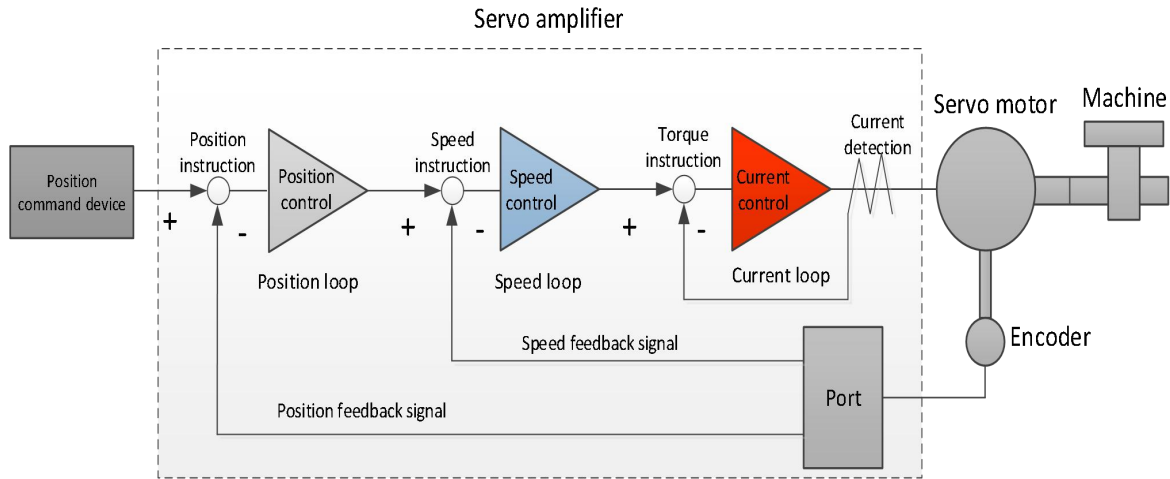


Figure 5 - 1 Servo system control diagram

The servo drive is the control core of the servo system. By processing the input signal and feedback signal, the servo drive can accurately control the position, speed and torque of the servo motor, that is, the position, speed, torque and mixed control mode. Among them, position control is the most important and commonly used control mode of servo system.

According to the command mode and operation control characteristics of the servo drive, it can be divided into three control modes, namely, position mode, speed mode and torque mode.

Position control is to control the position of the motor through the position command. The target position of the motor is determined by the total number of position instructions, and the rotation speed of the motor is determined by the position instruction frequency. By means of an internal encoder (the servo motor has its own encoder) or an external encoder (full closed-loop control), the servo drive can achieve fast and precise control of the position and speed of the machine. Therefore, the position control mode is mainly used in situations where positioning control is required.

Speed control is to control the speed of the machine through the speed command. By communicating the given speed instructions, the servo drive can achieve fast and accurate control of the mechanical speed. Therefore, the speed control mode is mainly used for the occasion of controlling the speed, or the occasion of using the upper computer to achieve position control, and the upper computer output as the speed command input to the servo drive.

The current and torque of the servo motor are linear, so the control of the current can realize the control of the torque. Torque control is to control the output torque of the motor through the torque command. Torque instructions can be given by communication.

5.1 Server Status

5.1.1 Server Status

The use of iSMK or FD1X5 servo drives must follow the DS402 protocol to guide the servo drive in order to operate in the specified state.

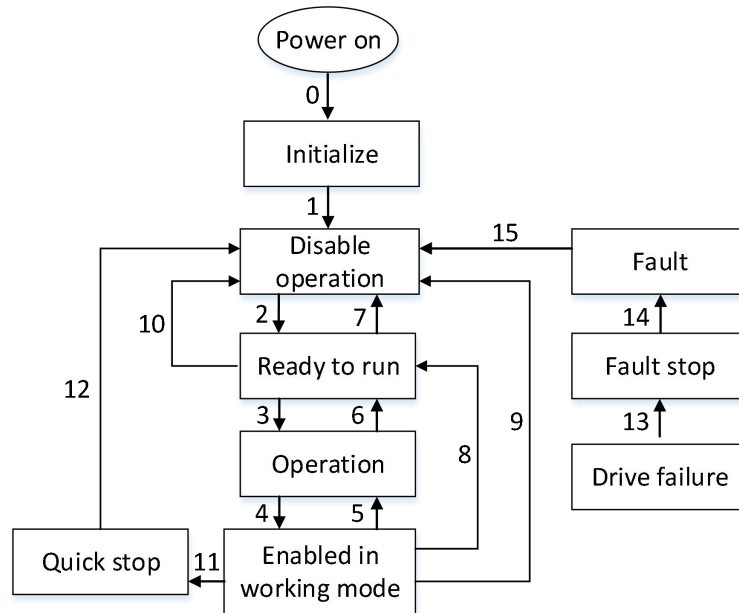


Figure 5 - 2 DS402 state machine

Each state is explained in the following table:

Table 5 - 1 State description

State	Explanation
Initialize	The drive is in the initializer state and cannot set parameters.
Disable operation	The drive is in the initializer state and cannot set parameters.
Ready to run	The drive is ready to run, you can set parameters to allow the drive to be enabled.
Operation	The driver main power circuit is ready but not powered, parameters can be set and allow the driver to be enabled.
Enabled in working mode	The driver is in the enable state, the main power circuit is energized to start the drive function, and the motor is running. Some parameters cannot be set in this state.
Quick stop	Execute the quick stop command and the motor stops according to the quick stop mode.
Fault stop	The driver fails and the motor stops according to the error stop mode.
Fault	The drive is in the faulty state and the fault shutdown has been completed. Enable the drive after troubleshooting and resetting the fault.

Table 5 - 2 Control commands and status switching description

Serial number	Status switching	Trigger event (bit3~bit0)	Drive state (bit7~bit0)
0	Power-on state → Initialization state	After the driver is powered on, it automatically switches the status without sending the control word	The drive initializes itself
1	Initialize state → Disable state	Automatically switches the status without delivering the control key	The drive communicates normally
2	Forbidden State → Ready State	Control word Enter 6	The status word is changed to 31
3	Ready State → Running state	Control word enter 7	The status word is changed to 33

4	Running State → Working Mode Enable state	Control word enter F	The status word is changed to 0037
5	Working Mode Enable state → Running state	Control word enter 7	The status word is changed to 0033
6	Running State → Ready state	Control word Enter 6	The status word is changed to 0031
7	Ready State → Disable State	Control word Enter 0	The status word is changed to 0070
8	Working Mode Enable status → Ready state	Control word Enter 6	The status word is changed to 0031
9	Working Mode Enable state → Disable State	Control word Enter 0	The status word is changed to 0070
10	Ready State → Disable State	Control word Enter 0	The status word is changed to 0070
11	Working Mode Enable state → Fast Stop state	Control word Enter 2	The status word is changed to 0050
12	Fast Stop state → Disable state	When the quick stop function is complete and the quick stop mode is 0, 1, 2, or 18, the drive automatically switches to the disabled state	Disable the driver and turn off the main power supply
13	→ Fault shutdown state	In the initialization, disable running, running ready, running, working mode enabled, fast stop state automatically switched when the fault condition is reached	Stop according to the error stop mode
14	Fault Stop state → Fault state	Automatic switchover	The status word is changed to 0038 The driver function needs to be disabled and the main power supply needs to be turned off
15	Fault state → Disable state	Control word Enter 86 Switch status Error reset command from I/O or remote control	The status word is changed to 0031 If the drive exception has been cleared, use the control word bit to clear the fault state
16	Quick Stop State → Working Mode Enable state	When the quick stop mode is 5 or 6, the control word input F switches the status	The drive function needs to be enabled

5.1.2 Control word and status word description

The following table describes the control words and status words:

Table 5-3 Control word and status word

Name	Index address	Property	Type	Unit	Explanation	Factory default
Control word	60400010	RWLTM	Uint16	HEX	bit0: Switch_on bit1: Enable_voltage bit2: Quick_stop bit3: Enable_operation bit4: Set_Point bit5: Immed_Change bit6: Related_Abs bit7: Fault_reset bit8: Halt bit9: Reserved0 bit10: Reserved1 bit11: Manufacture0 bit12: Manufacture1 bit13: Manufacture2 bit14: Manufacture3 bit15: Manufacture4	6

Status word	60410010	RLTM	Uint16	HEX	bit0: Ready_on bit1: Switched_on bit2: Operation_enable bit3: Fault bit4: Voltage_enable bit5: Quick_stop bit6: Switchon_disabled bit7: Warning bit8: Maunufacture0 bit9: Remote bit10: Target_reached bit11: Intlim_active bit12: Setpoint_Ack bit13: Following_Error bit14: Commutation_Found bit15: Reference_Found	-
-------------	----------	------	--------	-----	---	---

5.1.2.1 Control word description 604000

Table 5-4 Control word declaration

Control word	State	Meaning	Note	
bit0	0	Drive running - invalid	For details, see Table 5-2	
	1	Drive running - valid		
bit1	0	Main power circuit ready - invalid		
	1	Main power circuit ready - valid		
bit2	0	Quick stop - valid		
	1	Quick stop - invalid		
bit3	0	Servo running - invalid		
	1	Servo running - valid		
bit4	0→1	Indicate that a new displacement command is pre-enabled. Whether the command is successfully enabled depends on the servo state		Position mode
	1→0	Indicates that bit12 of control word 6041h is pre-cleared. Whether it is successfully cleared depends on the servo status		
	0	Origin mode is not activated	Origin mode	
	0→1	Active origin mode		
	1	The origin return to zero is in progress		
	1→0	Interrupt origin return to zero	Interpolation mode	
	0	Interrupt interpolation		
1	Enable interpolation			
bit5	0	Acceleration and deceleration, trapezoidal speed, target position is not updated	F→2F	
	1	Acceleration and deceleration, trapezoidal speed, target position update immediately		
bit6	0	Target position 607Ah is a position instruction for absolute positioning	Position mode	
	1	Target position 607Ah is a position instruction for relative positioning		
bit7	0→1	Fault reset - Rising edge effective	Fault reset	
	1	Fault reset complete		
bit8	1	The servo motor is suspended	Applicable to operating modes other than torque mode (4 mode)	
	0	Servo motor continues to run (continue to perform the previous task)		

bit9	Reserve		
bit10			
bit11			
bit12	0	The target position 607Ah is a position instruction for absolute positioning and does not update the contour trajectory according to the change of the target position	Position mode
	1	Target position 607Ah is a position instruction for absolute positioning, which updates the contour trajectory in real time according to the change of target position	
bit13	Reserve		
bit14			
bit15			
Motor lock shaft: 0x2F/0x0F Motor loose shaft: 0x06 Error reset: 0x86 Absolute position mode: 0x2F→0x3F Absolute positioning mode immediately as target position changes: 0x103F Relative position mode: 0x4F-->0x5F Find the origin: 0x0F->0x1F			

5.1.2.2 Status Word Description 604100

Table 5 - 5 Status word description

Control word	State	Meaning	Note
bit0	0	Servo no fault - invalid	For details, see Table 5-2
	1	Servo fault-free - valid	
bit1	0	Waiting to turn on the servo enable - invalid	
	1	Wait to turn on the servo enable - Valid	
bit2	0	Servo ready to run - invalid	
	1	Servo ready to run -valid	
bit3	0	Fault-invalid	
	1	Fault-valid	
bit4	0	Power on the main circuit-invalid	
	1	Power on the main circuit-valid	
bit5	0	Quick stop - valid*	
	1	Quick stop - invalid*	
bit6	0	Servo ready- invalid	
	1	Servo ready- valid	
bit7	0	The servo has no warning status word	
	1	Servo in warning status word	
bit8	Reserved, undefined		
bit9	0	DIN defines enable/reset faults, IO controls	
	1	Telecommunication control	
bit10	0	Target position, zero speed, target speed not reached	Target arrival
	1	Position, speed , zero speed reached	

bit11	0	The actual position does not reach the soft limit or hard limit	Positive/negative limit
	1	The actual position reaches the soft limit/hard limit position, and input the reverse shift instruction can make the motor exit the position limit state and clear the bit	
bit12	0	The servo can receive new displacement commands	position mode
	1	The servo cannot receive new shift instructions	
		Origin return to zero error	Origin mode
	0	User speed is not zero	Speed mode
1	User speed is zero		
bit13	0	The position following error does not exceed the maximum following error	Position following error
	1	The position following error exceeds the maximum following error	
bit14	0	No motor excitation found or motor excitation missing	Excitation state
	1	Motor excitation found	
bit15	0	The origin return to zero has not been performed or completed	Origin state
	1	The origin has been returned to zero. The reference point has been found	

5.2 Speed Mode (-3, 3) description

The speed mode has two modes: 3 and -3. The speed mode can be controlled by external I/O control and internal instruction writing.

Table 5 - 6 Speed mode parameters description

Internal address	Type	Name	Description	Value
6060.00	Integer8	Operation_Mode	-3: In immediate speed mode, the actual speed will immediately reach the target speed; 3: For the speed mode with acceleration and deceleration, the actual speed will be accelerated to the target speed;	-3 and 3
6040.00	Unsigned16	Controlword	0x0F Motor lock shaft 0x06 Motor loose shaft	0x0F.0x06
60FF.00	Integer32	Target_Speed	The target speed cannot exceed the rated motor speed	According to user demand
6083.00	Unsigned32	Profile_Acc	It takes effect in mode 1 and mode 3	The default is 100rps/s
6084.00	Unsigned32	Profile_Dec	It takes effect in mode 1 and mode 3	The default is 100rps/s
607E.00	Unsigned 8	Invert_Dir	invert motion 0: CCW is positive dirction (default value) 1: CW is positive direction	0.1



Note

The speed position direction control cannot be modified in the enabled state.

5.2.1 Related Function Settings

5.2.1.1 DIN Speed mode introduction

The setting interface of DIN speed segment opens in the upper computer software.

Table 5-7 DIN Speed mode introduction

Internal Address	Bits	Name	Description	Value
2020.05	Integer32	Din_Speed[0]	The speed instruction for the drive is specified by the DIN speed [x], where the x is the BCD code from the following signals: Bit 0: Din speed index 0; Bit 1: Din speed index 1; Bit 2: Din Speed index 2; The situation where all the medians are 0 cannot occur;	User defined
2020.06	Integer32	Din_Speed[1]		
2020.07	Integer32	Din_Speed[2]		
2020.08	Integer32	Din_Speed[3]		
2020.14	Integer32	Din_Speed[4]		
2020.15	Integer32	Din_Speed[5]		
2020.16	Integer32	Din_Speed[6]		
2020.17	Integer32	Din_Speed[7]		
6083.00	Unsigned32	Profile_Acc	When the operating mode is 3 mode, the trapezoidal acceleration and trapezoidal deceleration must be set, otherwise the response speed segment will not be performed	
6084.00	Unsigned32	Profile_Dec		

Table 5-8 DIN speed segment settings

DIN speed index 0	DIN speed index 1	DIN speed index 2	Corresponding velocity segment	Value
0	0	0	Din_Speed[0]	User defined
1	0	0	Din_Speed[1]	
0	1	0	Din_Speed[2]	
1	1	0	Din_Speed[3]	
0	0	1	Din_Speed[4]	
1	0	1	Din_Speed[5]	
0	1	1	Din_Speed[6]	
1	1	1	Din_Speed[7]	

0 means the signal is off, 1 means the signal is on.

The following points need to be noted when activating DIN speed mode:

1. DIN speed mode is only available in 3 or -3 operation_mode, invalid in other working modes.
2. Analog-speed control (250207) is 0, close the analog-speed channel.
3. At least one of DIN speed index 0, DIN speed index 1 and DIN speed index 2 is defined in the digital input DIN as the switching signal of the speed segment.

5.2.1.2 Speed to function

The Speed to window can be used to monitor whether the actual speed feedback is consistent with the target speed instruction. When the speed error window monitored in speed mode is less than the speed to window set value, the output speed is to, and the BIT10 of the status word is set to 1.

Relevant parameter:

Internal Address	Bits	Name	Description	Value
60F9.1C	Integer32	Speed_Error	Speed error window	\
60F9.0A	Integer32	Target_Speed_Window	Target_Speed_Window,Under velocity mode,if $ \text{Speed_Error} (60F9.1C) < \text{Target_Speed_Window}$ means target reached,Statusword Bit10=1;	Default 100rpm

5.2.1.3 Zero speed function

Zero speed monitoring can be used to verify that the absolute value of the motor's speed feedback is less than the zero speed window set value. If so, the current motor is considered to be close to the zero speed stationary state, and the bit12 of the status word is set to 1.

Relevant parameter:

Internal Address	Bits	Name	Description	Value
2010.18	Unsigned16	Zero_Speed_Window	When the absolute value of the actual velocity -ms (60F9.1A) is less than or equal to the zero velocity window (2010.18), and the duration is greater than or equal to the zero velocity time (60F9.14), the zero velocity function is output	Default 3inc/ms
60F9.14	Unsigned16	Zero_Speed_Time		Default 10ms

5.2.1.4 Maximum speed limit function

In speed mode, the maximum forward and reverse speed can be limited by setting the maximum speed limit 607F.00. However, it always does not exceed the maximum operating speed allowed by the motor.

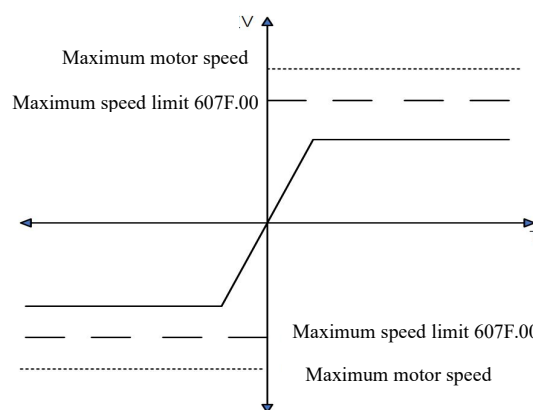


Figure 5-3 Maximum speed limit diagram

Relevant parameter:

Internal Address	Bits	Name	Description	Value
607F.00	Unsigned32	Max_Speed	Maximum motor speed limit	Default 5000rpm

5.3 Torque mode (4)

In torque mode, the driver will control the output torque of the motor set by the user during operation.

Table 5-9 Description of related parameters of torque mode

Internal Address	Bits	Name	Description	Value
6060.00	Integer8	Operation_Mode	Select the working mode according to the actual control mode. 4 is the torque mode	4
6071.00	Integer16	Target_Torque%	Percentage of the target torque to the rated torque	User defined
6040.00	Unsigned16	Controlword	Enable drive	0006→000f
607F.00	Unsigned32	Max_Speed	Motor operating maximum speed limit	User defined
60F5.06	Integer16	Torque_OUT_Ref	The limit value, the actual torque exceeds the reference data and the duration exceeds the filter time, the output torque of the Dout port reaches the setting, the unit is Ap	User defined
60F5.07	Integer16	Torque_OUT_Filter	When the actual torque reaches the reference value and the duration exceeds the filter time, Dout output torque reaches the setting, the unit is ms, the maximum is 32767	User defined
60F5.08	Integer16	Current_OUT_Real	Monitors the actual torque, the unit in Ap	/



Note

The torque reach setting function of Dout can be used in any working mode.

5.3.1 Related function Settings

5.3.1.1 Maximum speed limit function in torque mode

In torque mode, the maximum forward and reverse running speed can be limited by setting the maximum speed limit of 607F.00. However, it always does not exceed the maximum operating speed allowed by the motor.

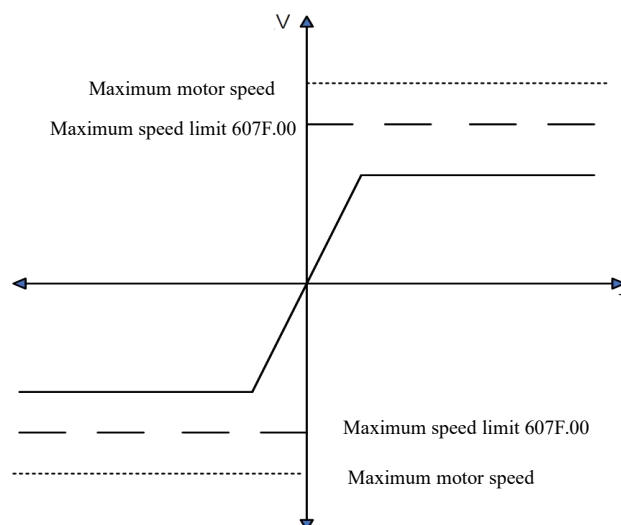


Figure 5-4 Maximum speed limit diagram

Relevant parameter:

Internal Address	Bits	Name	Description	Value
607F.00	Unsigned32	Maximum speed limit	Maximum motor speed limit	Default 5000rpm

5.3.1.2 Torque reaches the preset function

The torque reach function is to judge whether the target torque command value reaches the set torque reference value and output the corresponding torque reach signal for the host computer. When the actual torque reaches the set torque reaches the benchmark and the duration is the set torque reaches the filtering time, the corresponding signal is output.

Relevant parameter:

Internal Address	Bits	Name	Description	Value
60F5.06	Integer16	Torque_OUT_Ref	The limit value, when the reference data is exceeded, the output torque reaches the setting, the unit is Ap, and the setting is 0, which means that the torque reaches the limit detection is not enabled	Default 0Ap
60F5.07	Integer16	Torque_OUT_Filter	Torque reaches filtering time	Default 100ms
60F5.08	Integer16	Current_OUT_Real	Monitor actual torque parameters, unit : Ap	\

5.4 Position mode (1)

In the position mode, the driver control motor can carry out absolute position positioning and relative position positioning, and the speed and position instructions are controlled by the target position and ladder speed inside the driver.

Table 5 - 10 Position mode parameter description

Internal Address	Bits	Name	Description	Value
6060.00	Integer8	Operation_Mode	The way to control the servo motor	1
607A.00	Integer32	Target_Position	Target absolute/relative position	User defined
6081.00	Unsigned32	Profile_Speed	Speed command in position mode	User defined
6083.00	Unsigned32	Profile_Acc	Acceleration of trapezoidal curve	User defined
6084.00	Unsigned32	Profile_Dec	Trapezoidal curve deceleration	User defined
6040.00	Unsigned16	Controlword	0x2F->0x3F: activates the absolute position instruction, does not execute the absolute position instruction immediately according to the change of the target position, used when the working mode is 1 0x4F->0x5F: Activates the relative position instruction, used when the working mode is 1 0x103F: Absolute position command is executed immediately when the target position changes. This command is used when the working mode is 1 0x06->0x0F Enables the drive	0x2F->0x3F 0x4F->0x5F 0x06->0x0F 0x103F

5.4.1 Related function Settings

5.4.1.1 DIN Position mode introduction

First, at least one of the DIN position indexes 0, Din position indexes 1, and Din position indexes 2 must be defined in the I/O configuration as a switching signal for the position segment when using Din position mode.

The setting interface of DIN position segment can be opened through the menu bar of the upper computer software.

Table 5-11 DIN position mode introduction

Internal address	Bits	Name	Description	Value
2020.01	Integer32	Din_pos[0]	The speed instruction of the drive is specified by DIN speed [x], where x is a BCD code consisting of the following signals: bit 0: Din_pos[0]; bit 1: Din_pos[1]; bit 2: Din_pos[2]; The case where the digits are all 0 cannot occur;	User defined
2020.02	Integer32	Din_pos[1]		
2020.03	Integer32	Din_pos[2]		
2020.04	Integer32	Din_pos[3]		
2020.10	Integer32	Din_pos[4]		
2020.11	Integer32	Din_pos[5]		
2020.12	Integer32	Din_pos[6]		
2020.13	Integer32	Din_pos[7]		
2FF1.01	Unsigned8	Din_position_select_L	Select the position segment L to be set (L range is 0-7, corresponding to the internal position segment 0-7 in turn)	
2FF1.02	Integer16	Din_position_M	Number of pulses set in position segment (L) =M*10000+N	
2FF1.03	Integer16	Din_position_n		

Table 5-12 DIN position mode related IO Settings

DIN	Function introduction
Enable	Drive enable
Command activation	ctivate position instructions, such as the control word from 0x2F to 0x3F
DIN position Index 0	DIN position index [x] is specified, where the x is a BCD code composed of the following signals: Bit 0: Din position index 0; Bit 1: Din location index 1; Bit 2: Din location index 2;
DIN position Index1	
DIN position Index2	
DOUT	Function introduction
Multi-function signal 0	The driver executes the selected position segment program and outputs a multifunction signal after reaching the Din position [x], where the x is a BCD code composed of the following signals: Bit 0: multi-function signal 0; Bit 1: multi-function signal 1; Bit 2: multi-function signal 2;
Multi-function signal 1	
Multi-function signal 2	

Table 5-13 DIN position mode related Settings

Internal address	Name	Value	Unit
2020.0E	Din_Mode1	1	DEC
2020.02	Din_Pos1	User defined	DEC
2020.06	Din_Speed 1	User defined	rpm
6083.00	Profile_Acc	User defined	rps/s
6084.00	Profile_Dec	User defined	rps/s

After enabling, select the position segment to go, the simulation instruction is activated, the driver executes the selected position segment program, and outputs the multi-function signal 0 after reaching the Din position [1].



Remind

- In the multi-segment position mode, the position to signal of Din positions 1-7 segments is represented by the BCD code composed of the multi-function signal 0-2.
- Command activation can set the bit4 of the control word to activate the position command, and the level change of DIN position index 0~2 can also activate the position command, but when the first segment is positioned as DIN position 0 after enablement, DIN position 0 cannot be activated due to no level change of the non-index signal, so the DIN input port is required to define the command activation.

5.4.1.2 Position-to-function

The Position to window can be used to monitor whether the actual position feedback is consistent with the target position instructions. When the speed error window monitored in speed mode is less than the speed to window set value, the output speed to, BIT 10 of the status word is set to 1.

Relevant parameter:

Internal address	Bits	Name	Description	Value
60F9.1C	Integer32	Speed_Error	Speed error window	\
60F9.0A	Integer32	Target_Speed_Window	Target_Speed_Window,Under velocity mode,if $ \text{Speed_Error} (60F9.1C) < \text{Target_Speed_Window}$ means target reached,Statusword Bit10=1;	Default 100rpm

5.4.1.3 Position following error monitoring function

The position following error (60F4.00) function is to calculate the difference between the given instruction of the effective target position (60FC.00) and the feedback instruction of the actual position (6063.00). When the difference accumulates to the set maximum following error (6065.00) threshold, the alarm position following error is allowed to be too large.

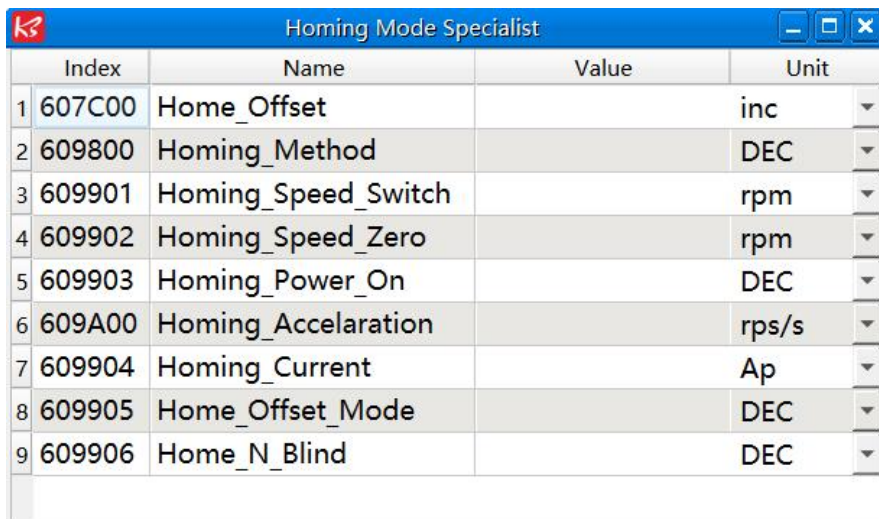
Relevant parameter:

Internal address	Bits	Name	Description	Value
6063.00	Integer32	Pos_Actual	The actual position of the motor	\
6065.00	Unsigned32	Max_Following_Error	Follow the error alarm limit value	Default 10rpm
60F4.00	Integer32	Pos_Error	The difference between the actual position and the effective target position	\
60FC.00	Integer32	Pos_Demand	Target position instruction after PID adjustment	\

5.5 Homing mode (6)

In some applications, the system requires every movement of the mechanical load to start from the same position, so the user can meet the demand by using the homing mode. In homing mode, the user can define an origin or zero point to ensure that the mechanical load runs from the same starting point every time. The operation interface

of origin mode can be opened by menu bar ->**Specialist** -> **Control Modes** -> **Homing mode**. The operation interface after opening is shown as follows:



Index	Name	Value	Unit
1	607C00 Home_Offset		inc
2	609800 Homing_Method		DEC
3	609901 Homing_Speed_Switch		rpm
4	609902 Homing_Speed_Zero		rpm
5	609903 Homing_Power_On		DEC
6	609A00 Homing_Accelaration		rps/s
7	609904 Homing_Current		Ap
8	609905 Home_Offset_Mode		DEC
9	609906 Home_N_Blind		DEC

Figure 5 - 5 Homing mode interface

Table 5 - 14 Homing mode parameter description

Internal address	Name	Bits	Value	Meaning
607C0020	Home_Offset	Integer32	User defined	The offset position setting of the final positioning from the origin position
60980008	Homing_Method	Integer 8	User defined	Find the origin of the way to choose
60990220	Homing_Speed_Zero	Unsigned32	User defined	Find the origin signal velocity
60990308	Homing_Power_On	Unsigned 8	0, 1	The origin search function is performed once after each power-on
609A0020	Homing_Accelaration	Unsigned32	User defined	Find the acceleration at the origin
60990120	Homing_Speed_Switch	Unsigned32	User defined	Look for the speed of the origin switch, limit switch signal
60990410	Homing_Current	Integer16	User defined	The maximum current setting when finding the origin
60990508	Home_Offset_Mode	Unsigned 8	0, 1	Origin offset mode control 0: Run to the origin offset 1: Run to the origin event trigger point, after the end of the actual position will be "- origin offset"
60990608	Home_N_Blind	Unsigned 8	0, 1	Origin index signal blind area
60600008	Operation_Mode	Integer8	6	Homing mode
60400010	Controlword	Unsigned16	0x0F->0x1F	Trigger back to origin



Note

Homing_Power_On=1 causes the motor to start rotating as soon as the controller is enabled after power on or reboot. Consider all safety issues before using.

Home_N_Blind:

If the homing mode needs home signal (position limit / home switch) and index signal, Home_N_Blind function can avoid the homing result being different with the same mechanics, when the Index signal is very close to the home signal. By setting to 1 before homing, the controller detects a suitable blind window for homing automatically. It can be used to assure that homing results are always the same.

During homing, the index signal inside this blind window is ignored after the home signal is found. Home_N_Blind (0:0rev;1:0.25rev;2:0.5rev) is defaulted to 0. If it's set to 1, it's changed to 0 or 2 after homing depending on the index signal position relative to the homing signal. This parameter needs to be saved. If the mechanical assembly is changed or the motor has been replaced, just set it to 1 again for initial homing.

Table 5 - 15 Homing mode introduction

Homing mode	Description	Schematic
1	Z phase pulse trigger signal with negative limit as origin	<p>Index Signal</p> <p>Negative Limit</p>
2	Z-phase pulse trigger signal with positive limit as origin	<p>Index Signal</p> <p>Positive Limit</p>
3	The origin switch signal is the Z-phase pulse trigger signal, and the initial motion direction is positive	<p>Index Signal</p> <p>Home Signal</p>
4	The origin switch signal is the Z-phase pulse trigger signal, and the initial motion direction is positive	<p>Index Signal</p> <p>Home Signal</p>

<p>5</p>	<p>The origin switch signal is the Z-phase pulse trigger signal, and the initial motion direction is negative</p>	
<p>6</p>	<p>The origin switch signal is the Z-phase pulse trigger signal, and the initial motion direction is negative</p>	
<p>7</p>	<p>With double limit, the origin switch signal is the Z-phase pulse trigger signal, and the initial direction of movement is positive</p>	
<p>8</p>	<p>With double limit, the origin switch signal is the Z-phase pulse trigger signal, and the initial direction of movement is positive</p>	

<p>9</p>	<p>With double limit, the origin switch signal is the Z-phase pulse trigger signal, and the initial direction of movement is positive</p>	<p>Index Signal</p> <p>Home Signal</p> <p>Positive Limit</p>
<p>10</p>	<p>With double limit, the origin switch signal is the Z-phase pulse trigger signal, and the initial direction of movement is positive</p>	<p>Index Signal</p> <p>Home Signal</p> <p>Positive Limit</p>
<p>11</p>	<p>With double limit, the origin switch signal is the Z-phase pulse trigger signal, and the initial movement direction is negative</p>	<p>Index Signal</p> <p>Home Signal</p> <p>Negative Limit</p>
<p>12</p>	<p>With double limit, the origin switch signal is the Z-phase pulse trigger signal, and the initial movement direction is negative</p>	<p>Index Signal</p> <p>Home Signal</p> <p>Negative Limit</p>

<p>13</p>	<p>With double limit, the origin switch signal is the Z-phase pulse trigger signal, and the initial movement direction is negative</p>	<p>Index Signal</p> <p>Home Signal</p> <p>Negative Limit</p>
<p>14</p>	<p>With double limit, the origin switch signal is the Z-phase pulse trigger signal, and the initial movement direction is negative</p>	<p>Index Signal</p> <p>Home Signal</p> <p>Negative Limit</p>
<p>17</p>	<p>Take the negative limit as the origin signal</p>	<p>Negative Limit</p>
<p>18</p>	<p>Take the positive limit as the origin signal</p>	<p>Positive Limit</p>

<p>19</p>	<p>The external origin switch is the origin trigger signal, and the initial motion direction is positive</p>	
<p>20</p>	<p>The external origin switch is the origin trigger signal, and the initial motion direction is positive</p>	
<p>21</p>	<p>The external origin switch is the origin trigger signal, and the initial motion direction is negative</p>	
<p>22</p>	<p>The external origin switch is the origin trigger signal, and the initial motion direction is negative</p>	

<p>23</p>	<p>With double limit, the external origin switch is the origin trigger signal, and the initial direction of movement is positive</p>	
<p>24</p>	<p>With double limit, the external origin switch is the origin trigger signal, and the initial direction of movement is positive</p>	
<p>25</p>	<p>With double limit, the external origin switch is the origin trigger signal, and the initial direction of movement is positive</p>	
<p>26</p>	<p>With double limit, the external origin switch is the origin trigger signal, and the initial direction of movement is positive</p>	

<p>27</p>	<p>With double limit, the external origin switch is the origin trigger signal, and the initial direction of movement is negative</p>	
<p>28</p>	<p>With double limit, the external origin switch is the origin trigger signal, and the initial direction of movement is negative</p>	
<p>29</p>	<p>With double limit, the external origin switch is the origin trigger signal, and the initial direction of movement is negative</p>	
<p>30</p>	<p>With double limit, the external origin switch is the origin trigger signal, and the initial direction of movement is negative</p>	
<p>33, 34</p>	<p>Take the next Z phase pulse signal of the motor as the origin</p>	
<p>35</p>	<p>Take the current position of the motor as the reference origin</p>	
<p>-17, -18</p>	<p>Refer to the origin mode where the mechanical end position is the origin</p>	

5.6 Pulse mode (-4)

FD1X5 driver supports a pulse mode in which the target speed command is determined by the external pulse frequency and the electronic gear ratio.

Table 5-16 Pulse mode parameter description

Internal address	Bits	Name	Description	Value
6060.00	Integer8	Operation_Mode	Setting operation mode	-4
2508.01	Integer16	Gear_Factor[0]	Gear_ratio=Gear_Factor/Gear_Divider	User define
2508.02	Unsigned16	Gear_Divider[0]		
6040.00	Unsigned16	Controlword	Enable drive	0x2F
2508.03	Unsigned8	PD_CW	Pulse train mode 0: CW / CCW 1: Pulse / direction 2: A / B (incremental encoder)	0,1,2
2508.06	Unsigned16	PD_Filter	Master_encoder pulse input filter	User define
2508.08	Unsigned16	Frequency_Check	Main encoder port pulse input pulse frequency alarm point set	

Table 5-17 Pulse input supported by the drive

Pulse mode	Forward	Reverse
P/D		
CW/CCW		
A/B		

➔

Note

- Forward indicates positive position count, default direction is CCW;
- The speed position direction control (607E.00) = 1 to reverse the direction of the motor shaft.

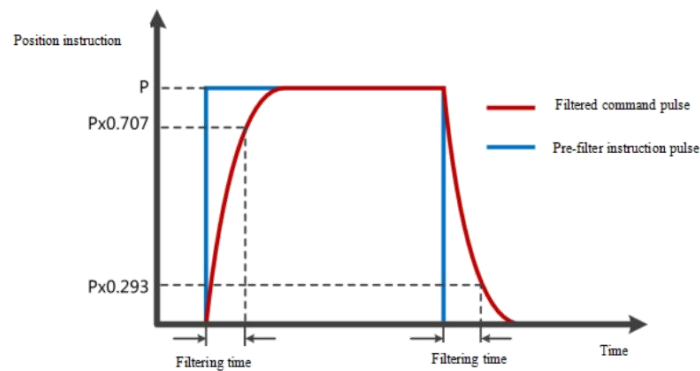


Figure 5-6 Pulse filter

5.7 Other application control functions

5.7.1 Limit function

In order to ensure that the motor runs within the range allowed by the mechanical structure, the motor can be prevented from running beyond the range by inputting a limit signal.

Table 5-18 Limit setting instruction

Internal address	Bits	Name	Description
2010.06	Unsigned16	DIN4 Function	Define digital input DIN 4. Default value 0010, Indicates the definition of the positive limit function
2010.07	Unsigned16	DIN5 Function	Define digital input DIN5. Default value 0020, Indicates the definition of the negative limit function
2010.1B	Integer32	Positive limit position	Actual position when the digital input signal triggers the positive limit
2010.1C	Integer32	Negative limit position	Actual position when the digital input signal triggers the negative limit
2010.19	Unsigned8	Limit function define	The function of defining whether to alarm after the limit signal occurs 0: If the limit signal appears after homing, it will alarm 1: it will not alarm when the limit signal appears after homing
607D.01	Integer32	Positive setting of soft limit	Soft limit positive polarity data setting
607D.02	Integer32	Soft limit negative setting	Soft limit negative data setting, the negative data must be less than the positive data, otherwise the soft limit will not work
6085.00	Unsigned32	Quick stop deceleration	Stop deceleration after the limit signal takes effect

(1) Digital input limit digital

By installing the sensor in the machine and connecting the external sensor signal to the digital input signal port of the drive, when the sensor level changes, the positive and negative limit signals take effect, and the motor stops. For safety reasons, the positive/negative limit signals are normally closed. When the valid input is 1 (the valid input is green), the limit function is invalid. When the valid input is 0 (the valid input is gray), it means that the limit is activated and the corresponding movement direction is prohibited.

(2) Soft limit position

To prevent overtravel by setting the position of the software limit, it should be noted that the position of the software limit only takes effect after homing. When the actual position reaches the set software limit position, the motor stops.

5.7.2 Motor brake control

FD1X5 and iSMK series do not need an external 24V power supply when using the internal brake!

In order to ensure that the motor will not be affected by gravity or other external forces after power off and rotation, load equipment such as vertical shaft need to choose brake motor, driver factory default OUT5 for brake control interface, please see 5.7.2.1 for details.

Table 5-19 Brake control related objects

Internal address	Bits	Name	Description
6410.17	Unsigned8	Additional device	whether the motor has any addition device 0: Motor without brake 1: Motor with brake,before the brake close totally,driver will keep working for some time
6410.11	Unsigned16	Brake duty cycle	Duty cycle of the lock signal. By changing the on-time (pulse width) and switching frequency of the switching device, the output voltage or current is controlled to reduce the temperature rise. The duty cycle of the lock is adjustable from 0 to 100%, corresponding to the average chopper voltage from 0 to 24V. The default value is 70%, that is, the lock supply voltage is $24*70\%=16.8V$
6410.12	Unsigned16	Brake delay	Brake signal delay time. The default value is 150ms
605A.00	Integer16	Quick stop mode	0: stop without control 1: stop by using ramp, then switch off 2: stop by using quick stop deceleration, then switch off 5: stop with profile deceleration, stay in quick stop active 6: stop with quick stop deceleration, stay in quick stop active 18: using motor winding for brake even encoder is wrong The factory default is stop without control mode
6085.00	Unsigned32	Quick stop deceleration	Deceleration when thequick stop mode is 2

**Note**

It is not recommended that the duty cycle of the brake be less than 40% or higher than 90%. Otherwise, the brake cannot be opened or the lock heats up.

After the control word is written into the enable command, the servo motor is energized to lock the shaft, and the driver outputs 24V DC to the brake after the relay pull-in delay for a certain period of time (brake delay) to make the brake open as soon as possible. After the delay, the speed command takes effect and the motor starts to run.

When the stop enable command is written in the control word, the control of the holding brake is related to the set quick stop mode.

When the quick stop mode is 0 (uncontrolled stop), the drive will automatically switch to the immediate speed mode (-3) and set the target speed to 0 internally to make the motor stop as soon as possible, in the uncontrolled stop mode After the drive changes the target speed, it will immediately cut off the 24V power supply to the brake. After the brake power is cut off and lasts for a certain period of time (the brake delay), the drive actually enters the disabled state, and the motor is powered off and the shaft is released.

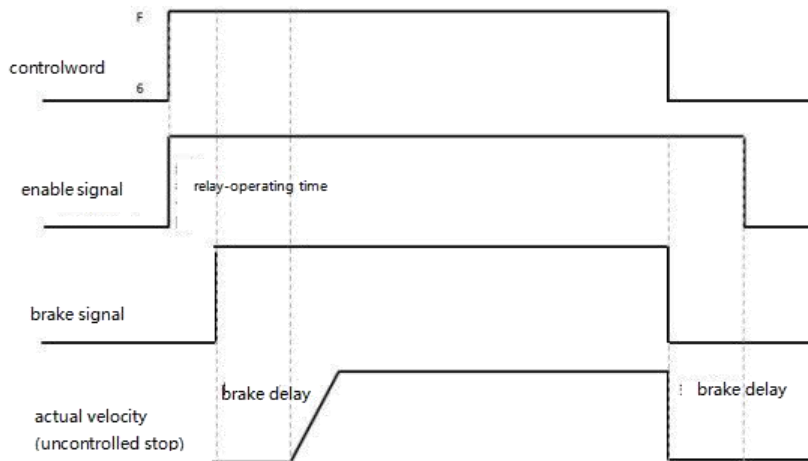


Figure 5-7 Motor holding brake sequence when quick stop mode is 0

When the quick stop mode is 2 (quick stop deceleration stop), the drive automatically switches to speed mode (3) and decelerates to stop at quick stop deceleration (60850020) when it is disabled. Only after the drive judges that the effective target speed is zero speed, the drive will cut off the 24V brake power supply. After the brake power supply has been cut off for a certain period of time (the brake delay time), the drive will enter the disabled state, and the motor will be disconnected from the power supply.

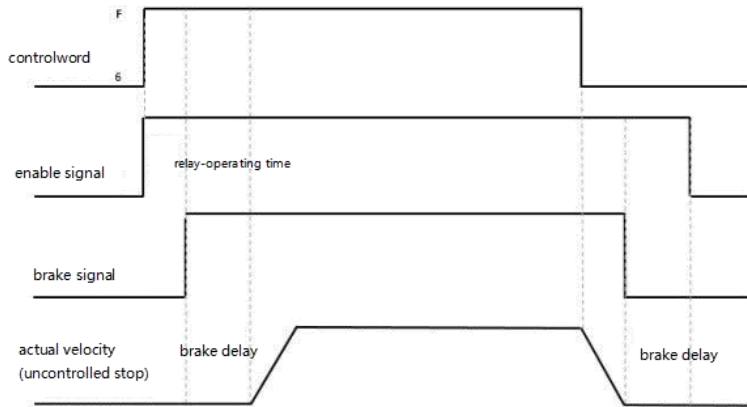


Figure 5-8 Motor brake sequence when quick stop mode is 2



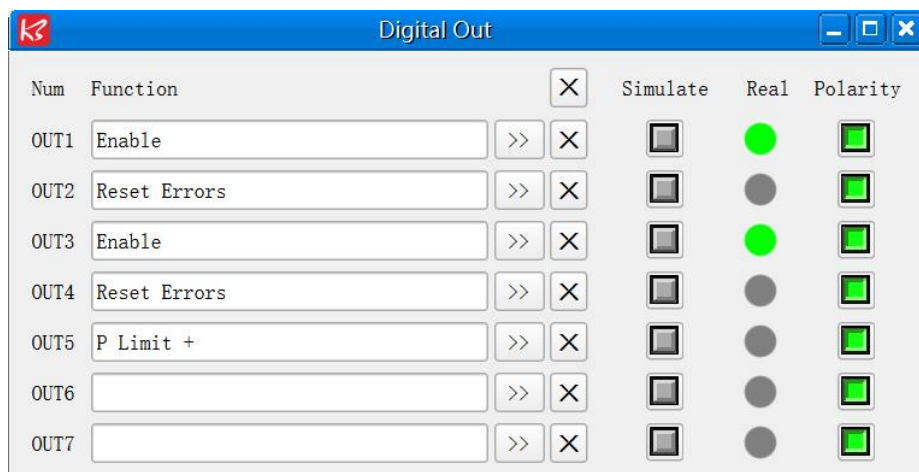
Note

After the motor accessory is set to 1, the load drop will be disabled, and the brake delay can be appropriately increased. If adjusting the brake delay cannot improve the problem, check whether the brake torque meets the load demand.

5.7.2.1 Motor brake signal function introduction

OUT5 is the motor brake control output signal, which can be used to control the internal brake. If the brake motor is used, this function must be set, otherwise it will damage the motor. An effective output of green indicates that the brake is opened, and an effective output of gray indicates that the brake is closed.

Brake can also be manually controlled, after the "motor brake" of OUT5 is removed, click the simulation button, the effective output becomes green, indicating that the brake is opened, and then click the simulation button, the effective output becomes gray, indicating that the brake is closed. This feature is for debugging only!



5.7.3 Stop Mode Control

The motor can be stopped in the following ways:

0. uncontrolled stop; the motor will directly cut off the power to loosen the shaft without any control, and stop naturally by friction. After the stop is completed, the motor loosens the shaft. The uncontrolled stop mode has a longer deceleration time, but less mechanical impact.
1. The curve stops; it stops according to the trapezoidal deceleration (60840020) curve, and the motor loosens the shaft after the stop is completed.
2. Quick stop deceleration stop; stop according to the quick stop deceleration (60850020), and the motor loosens the shaft after the stop is completed.
18. Short-circuit braking stop mode, use the motor's own resistance to stop. After the stop is completed, the motor keeps the shaft locked and stops in the fast stop state. It can be enabled after the control word sends 0x06 to exit the fast stop state. A stop mode that can quickly complete a stop even in the event of an encoder failure.
5. Stop according to the trapezoidal deceleration (60840020). After the stop is completed, the motor keeps the axis locked and stops in the fast stop state. It can be enabled after the control word 0x06 is issued to exit the fast stop state.
6. Stop according to the quick stop deceleration (60850020). After the stop is completed, the motor keeps the axis locked and stops in the quick stop state. It can be enabled only after the control word sends 0x06 to exit the quick stop state.

Table 5-20 Stop controlling related objects

Internal address	Bits	Name	Description
605A.00	Integer16	Quick_Stop_Mode	quick stop mode (Controlword.bits.2=0, eg:Controlword=0x0F->0x0B) 0: stop without control 1: stop by using ramp, then switch off 2: stop by using quick stop deceleration, then switch off 5: stop with profile deceleration, stay in quick stop active 6: stop with quick stop deceleration, stay in quick stop active 18: using motor winding for brake even encoder is wrong
605B.00	Integer16	Shutdown_Stop_Mode	Shutdown stop mode The control word is switched to 0x06, and the motor switches from the lock shaft to the loose shaft state 0: stop without control 1: stop by using ramp, then switch off 2: stop by using quick stop deceleration, then switch off 18: using motor winding for brake even encoder is wrong
605C.00	Integer16	Disable_Stop_Mode	Disable stop mode Stop mode when bit3 in the control word is set to 0 For example, the control word is changed from 0x0F to 0x07 0: stop without control 1: stop by using ramp, then switch off 2: stop by using quick stop deceleration, then switch off 18: using motor winding for brake even encoder is wrong

605D.00	Integer16	Halt_Mode	Halt mode Pause mode when bit8 in the control word is set to 1 For example, the control word is changed from 0x0F to 0x10F 1: stop by current ramp 2: stop by quick stop deceleration
605E.00	Integer16	Fault_Stop_Mode	Fault stop mode The false stop mode will be activated after the motor is alerted in the locked shaft state. 0: stop without control 1: stop by using ramp, then switch off 2: stop by using quick stop deceleration, then switch off 18: using motor winding for brake even encoder is wrong
6084.00	Unsigned32	Profile_Dec	Deceleration of trapezoidal curve
6085.00	Unsigned32	Quick_Stop_Dec	Deceleration for quick stop
2340.01	Unsigned8	Step_Stop_Mode	The step mode stop enable is only effective under position control. When the position reaches the signal output, the motor locks the shaft by step (that is, the driver passes direct current to the motor to keep the motor locked shaft), and the lock shaft current is set by step stop current (2340.02). 0: disables the function in step mode. 1: disables the function in step mode
2340.02	Integer16	Step_Stop_Amp	The stop current after the step stop mode is enabled

5.7.4 Absolute value system instruction

5.7.4.1 Multi-turn motor power-on configuration

When the absolute encoder motor is connected to the driver for the first time, the driver will appear 000.4 encoder UVW fault or communication fault alarm, which can be cleared by resetting the status marker of the encoder.

Table 5-21 Absolute value encoder parameters

Internal address	Bits	Name	Description	Default
2690.00	Unsigned8	Communication encoder data reset	Communication encoder command Write: 1: clear encoder status 2: Read the fault word, the fault status can be viewed at 0x30510110 3: Clear encoder status and multi-turn data 8 Reset the status flag of the encoder 9 Clear multi-lap data 10 Reset encoder status flag and clear multi-turn data operation 12 Clear the single-turn data (requires the manufacturer's password) Read: bit 0: 1 = Command can be entered bit 1: 1 = Last command execution completed Note: Clearing the single-turn data will cause the motor phase error. It is forbidden to clear the single-turn data when the motor can run normally!	1

2680.00	Unsigned16	Warning status word	Encoder alarm status word bit 0: battery alarm bit 1: Hybrid alarm (overspeed, overtemperature) bit 2: Encoder busy (motor speed too high at power-on) Note: When the drive has warning data, the panel will flash the warning status, and the warning status will not stop the operation of the drive.	0
2340.0E	Unsigned8	Encoder multi-turn prohibited	0: default 1: Use the multi-turn encoder as a single-turn encoder	0
3051.01	Unsigned16	Encoder warning message	Help:encoder warning messages Nikon internal error of encoder Bit0: BATT Bit1: MTERR Bit2: 0 Bit3: OVSPD Bit4: MEMERR Bit5: STERR Bit6: PSERR Bit7: BUSY Bit8: MEMBUSY Bit9: OVTEMP	0



Note

- After the communication encoder data is reset, the drive alarm will not be cleared directly. It is necessary to clear the drive alarm through the control word or restart the drive.
- After clearing the multi-turn fault, if the connection between the encoder wire and the motor end is disconnected, the drive will have fault 000.4 again, and the encoder state needs to be reset.
- After clearing the multi-turn data through the communication encoder data reset, the actual position single-turn data will not be cleared at this time. To reset the actual position, you need to use the 35 homing mode to return to the origin.

5.7.4.2 Multi-Circle Data Range

YAK/YBK absolute encoder motor single-turn resolution 8388608 (23bit), multi-turn number 65536, the actual position value after the positive multi-turn data overflow changes from 2147418112 to -2147418112, the negative multi-turn data overflow after the actual position value Changed from -2147483648 to 2147483648, the motor rotation direction remains unchanged after overflow.

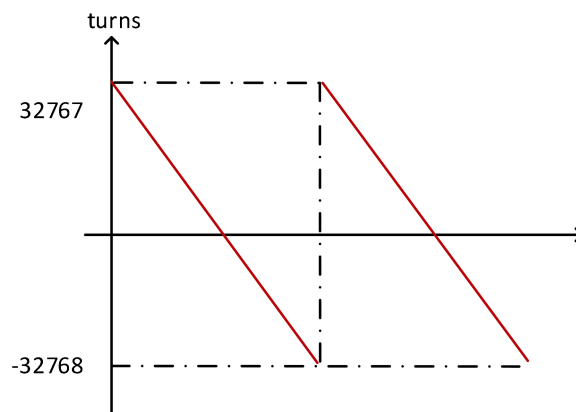


Figure 5-9 Multi-turn data range

5.7.4.3 Multi-turn prohibition

Set encoder multi-turn disable (0x23400E) to 1, absolute encoder can be used as incremental encoder without connecting battery. However, it should be noted that when the multi-turn prohibition is turned on, the position of the encoder cannot be saved after the power is turned off.

5.7.4.4 Battery instruction

When the battery voltage is below 3.1V, the driver appears the warning status word 0001, but the driver does not alarm for shutdown at this time. Under the condition that the driver remains properly powered and the encoder cable is properly connected, the battery replacement will not cause multiple data loss.

When the battery voltage is lower than 2.5V, the encoder UVW fault or internal fault (fault code 000.4) occurs in the driver. At this time, the motor stops running, the data is lost in multiple turns, and the absolute encoder needs to be re-initialized after the battery is replaced.



Note

- The battery must be used within a limited temperature range, away from high temperature and high humidity environments, and without dust or inflammable and explosive substances.
- During transportation and assembly, be careful not to impact and squeeze the battery, so as not to damage the battery.
- Before using a battery that has been placed for a long time, check whether the battery is swollen or not.
- Do not short-circuit the positive and negative poles of the battery, otherwise the battery may burst.
- The battery is a one-time item, do not charge the battery.
- Please dispose of batteries according to local regulations.

Table 5-22 Battery specification

Battery name	Lithium thionyl chloride battery
Standard Voltage	3.6V
Standard capacity	2700mH
Maximum continuous discharge current	60mA
Maximum pulse capacity	150mA
Weight	19g
Operation temperature	-55℃~85℃
Storage temperature	-55℃~115℃

5.7.5 Motor configuration instructions

FD1X5 uses the Tonomagawa encoder by default. When the motor needs to be configured, the motor parameters can be configured in the following ways

Relevant parameter:

Internal address	Bits	Name	Description
3041.06	Unsigned8	Use an in-house motor library	1: The user enters the motor model manually and uses the motor parameters corresponding to the motor library in the driver 2: Read and use the motor parameters saved in the encoder
6410.01	Unsigned16	Motor model	Motor code (generally the first two digits of S/N code on the motor nameplate)

If you need to use FD1X5 to adapt to the SMC-Q series motor of FD1X4-005 (Tamagawa protocol) :

I. Use the internal motor parameters of the driver: use the internal motor library to set 1 + input Q series motor model (such as Q7). After saving the motor parameters and restarting, initialize the control parameters. (Currently FD1X5 supports setting 'Q0/Q1/Q2/Q4/Q6/Q7/Q8', and SMC-Y series motor code is not added in the bottom layer)

II. Automatically read the internal data of the encoder: use the internal motor library set to 2 + motor model (such as Q4), save the motor parameters and restart.

To use FD1X5 compatible SMK multi turn motor (Such as multi-turn R4 motor :SMK60S-0040-30QAK-5DSA):

I. Automatically read the internal data of the encoder: use the internal motor library set to 2 + motor model (such as R4), save the motor parameters and restart.



Note

iSMK series drives are all-in-one drives that come out of the factory to configure motor parameters without changing them

Method 1:

Manually input the motor model and configure the motor parameters.

Step 1. Correctly connect the encoder wire of the motor according to the encoder definition

Step 2. Set internal motor library to 1

Step 3. Set "Motor Model" to the corresponding "Motor code" on the motor nameplate or open the corresponding motor drawing to find the corresponding "Motor code"

Step 4. Save the motor parameters and restart

Step 5. After the restart, initialize the control parameters, store the control parameters, and restart again

Method 2:

Set up the internal motor library to read the motor parameter configuration, Multi-turn motor must use this setting.

Step 1. Correctly connect the encoder wire of the motor according to the encoder definition

Step 2. Set internal motor library to 2

Step 3. There are two configuration methods:

① Set "Motor Model" to 00, After restart, the corresponding control parameters are automatically generated according to the read motor parameters, namely, current/speed/position loop parameters, no need to manually initialize the control parameters

② Set "Motor Model" to the Motor code on the motor nameplate (e.g. R4), then the motor data inside the encoder will be automatically read after restart, but the control ring parameters will not be initialized.

Step 4. Save the motor parameters and restart

Method 3:

According to the motor drawing, manual configuration of motor parameters, FD1X5 driver currently only supports Tama Agawa communication encoder

Step 1. Correctly connect the encoder wire of the motor according to the encoder definition

Step 2. Set internal motor library to 1

Step 3. Set "Motor Model" to VX (Tamagawa Encoder)

Step 4. Set Feedback Type to 04

Step 5. Set the "feedback accuracy" to the motor encoder feedback accuracy:

- Incremental: Number of encoder lines x 4
- Communication type: the resolution of a single turn is less than 16 bits set to the actual encoder resolution; Single-turn resolution higher than 16 bits is generally set to 65536 to prevent position overflow.

Step 6. Set Feedback Cycle as follows:

- Incremental: the number of pulses per turn of the motor
- Communication type: Define the encoder type, for example, multi-turn 16-bit, single turn 17-bit, and feedback period set to 0x1617 for the Tameragawa encode

Step 7. Set Excitation Mode as follows:

- Excitation mode 0: Use current to search for excitation
- Excitation mode 1: Use the data defined by the manufacturer to find excitation
- Excitation mode 10: micro-jitter excitation, determine the direction of operation
- Excitation Mode 9: Use custom excitation to find excitation

"Excitation current" setting is smaller than the rated current, generally 0.75 times the rated current of the motor

Step 8. Set Motor IIt Current to the rated current of the motor

Step 9. Configure other motor parameters according to the drawing

Step 10. Save the motor parameters and control parameters and restart

Step 11. After the restart, initialize the control parameters, save the control parameters, and restart

Common problems in configuration:

Common problem	Solution
The motor model cannot be entered or entered incorrectly	This drive does not support manual input of this motor model, please try to use method 3 for manual configuration
When using internal motor library 2, the motor model cannot be read after restart	Try to use mode 1, manually enter the motor model to configure or use mode 3 to manually configure the motor parameters
After configuring the motor parameters, the encoder is still warned of failure	Please check whether the motor configuration parameters are incorrect and connect the encoder cable of the motor correctly
After configuring the motor parameters, restart and alarm 0004 separately	When the multi-turn motor is powered on for the first time, the alarm of the encoder can be cleared by resetting the status mark of the encoder

Chapter 6 Performance adjustment

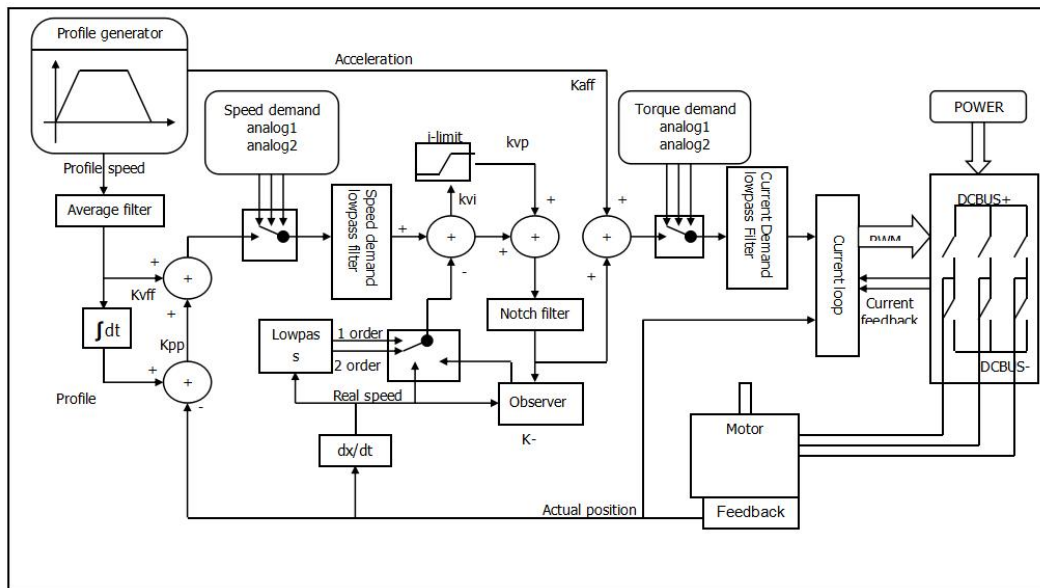


Figure 6-1 Servo system control block diagram

Figure 6-1 shows the servo system control block diagram. It can be seen from the figure that the servo system generally includes three control loops: current loop, velocity loop and position loop. For the servo system, good control loop parameters can improve the performance of the servo and better meet the field process requirements. Therefore, it is necessary to adjust good control loop parameters.

The parameters of speed loop and position loop should be adjusted during debugging. The speed loop parameter is related to the load inertia of the whole mechanical system converted to the motor shaft. The position loop is the outermost control loop of the servo system and is related to the motor action mode, that is, the field application. The current loop is the innermost control loop in the servo system, and the current loop parameters are related to the motor parameters. After the motor is correctly configured, the system defaults the current ring parameters to the best parameters of the configured motor, so there is no need to adjust again.



Remind

- kaff: Position loop acceleration feedforward
- kvff: Position loop speed feedforward
- kvp: Velocity loop proportional gain
- kvi: Velocity loop integral gain
- kpp: Position loop proportional gain

6.1 Online auto-tuning

The online auto-tuning function of the servo drive does not need to be separated from the controller program, and can be turned on at the touch of a button during the movement of the machine, by automatically calculating the load inertia and automatically adjusting the gain to the load state.

Table 6-1 Online auto-tuning function related parameters

Object index	Name	Description	Default	Range	R: read W: write S: save
0x234010	Auto_Tuning_Control	The BCD code consists of the following bits to determine the self-tuning mode: Bit0: Enables online self-tuning Bit1: Automatically adjusts kvp after online self-tuning Bit2: The acceleration feedforward is automatically adjusted after the online self-tuning Bit4: No self-tuning when running forward Bit5: No self-tuning when running in reverse Bit7: Use friction to calculate the load	12	0-31	RWS

6.2 Manual tuning

6.2.1 Speed loop setting method

Table 6-2 Speed loop parameter

Internal address	Name	Description	Default	Range
60F901	kvp[0]	Setting reaction speed of speed loop	/	1-32767
2FF00A	Velocity_BW	Changing this parameter changes kvp[0] by the inertia ratio	/	1-700
60F902	Kvi[0]	Integral velocity loop gain	/	0-1023
60F907	Kvi/32	It is 1/32 of Kvi, used for high resolution encoder.	/	0-32767
2FF019	Kvi_Mix	The value of this parameter is 0x60F902 cross 32 plus 0x60F907. Writing this parameter sets 0x60F902 to 0, and the value is 0x60F907	/	0-16384
60F905	Speed_Fb_N	Used to set speed feedback filter bandwidth. Filter bandwidth=100+Speed_Fb_N*20	7	0-45
60F906	Speed_mode	Used to set the speed feedback mode 0: 2nd order FB LPF 1: Directly feedback the original velocity 2: Speed feedback after velocity observer 4: Speed feedback after 1st order LPF 10: Speed feedback after 2nd order LPF and the speed command is filtered by a 1st order LPF. Both filters have the same bandwidth. 11: The speed command is filtered by a 1st order LPF 12: Speed feedback after speed observer, the speed command is filtered by a 1st order LPF 14: Speed feedback after 1st order LPF and the speed command is filtered by a 1st order LPF. Both filters have the same bandwidth Bit7: 1: Use 8K Velocity loop sampling frequency and 2K position loop sampling frequency (for 23-bit encoders) 0: Use 4K Velocity loop sampling frequency and 1K position loop sampling frequency	0	/
60F915	Output_Filter_N	A 1st order lowpass filter in the forward path of the velocity loop	1	100-1370
60F908	Kvi_Sum_Limit	Integral output limit of the velocity loop	/	0-2 ¹⁵

Speed loop adjustment steps are as follows:

Step 1: Adjustment for Kvp

Increasing Kvp can improve the bandwidth of the velocity loop and make the velocity response ability faster. To calculate the Kvp, please refer the following formula:

$$kvp = \frac{1.853358080 \times 10^5 \times J \times \pi^2 \times B}{I_{Max} \times Kt \times Encoder}$$

Kt	Motor torque constant, unit N.m/Arms*100
J	System moment of inertia, unit kg*m ² *10 ⁶
B	Speed loop bandwidth, unit Hz
I _{Max}	Maximum current (6510.03) in DEC
Encoder	Encoder resolution

Because the -3 of Operation_mode has no acceleration and deceleration and does not participating the velocity loop control, the -3 mode and automatic flip mode can be used to run the motor when adjusting the velocity loop parameters. During the reciprocating motion, the responsiveness of the servo can be monitored by collecting the speed step curve

If the Kvp too low, the bandwidth of the velocity loop and the position loop will not match, which will lead to oscillation. If the Kvp is too high, it will cause the speed to overshoot and cause the speed loop to oscillate. In some rigid connection loads (such as ball screw, rack and pinion, etc.) The Kvp should be as high as possible. By comparing the oscillograms under different Kvp, find the optimal curve – the actual speed curve should be tight follows the target command and does not have velocity oscillations.

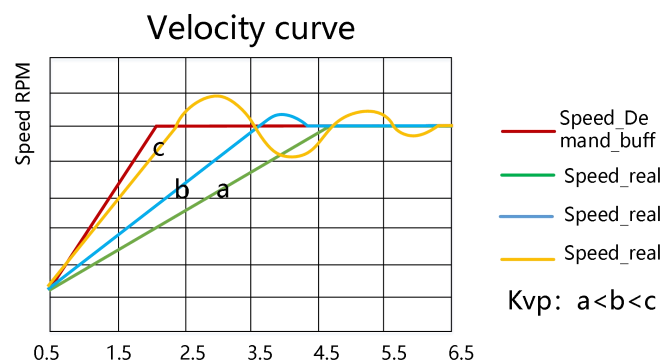


Figure 6-2 Speed step curve after Kvp adjustment



Remind

- Speed step curve: Curve that shows rise/fall changes.
- The vibration and noise of the motor can be felt by hand touch and listening

Step 2 : Adjustment for Kvi

Kvi is designed to eliminate static errors. It can strengthen the low frequency gain of the velocity loop, and a large Kvi can reduce the response ability from low-frequency disturbance, thereby improving the anti-disturbance capability in low-frequency.

When Kvi is too small, The integral time will be long. The error adjustment will be slow, and it will take longer time to make the system entering steady state. When the integral gain of the speed loop is too large, the error will appear and in severe cases, the motor may oscillate. Kvi should be adjusted to the servo eliminating the error and enter a stable state efficiently.

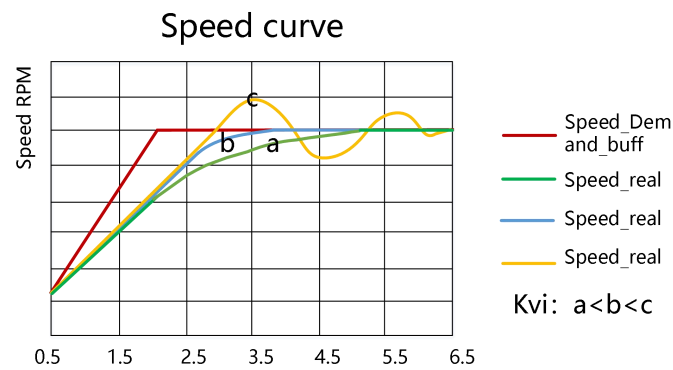


Figure 6-3 Speed step curve after Kvi adjustment

Generally, if the machine has more friction, the kvi should be set larger. If the entire system needs to respond quickly, kvi should be set as small as possible. If you need to dynamically close kvi during operation, you can use the kvi close in Din function.



Remind

- $Kvi32 = 1/32$ of $Kvi[0]$, In high resolution encoder, directly increasing the data in the $kvi[0]$ will lead to overshoot. At this time, you can reduce the data in $kvi[0]$, and fine-tune it in the $kvi32$
- Generally, the parameters of kpp and kvi are relative. When the kpp data is adjusted to be much larger than the factory value, the kvi should also be appropriately increased on the basis of the factory value.

Step 3: Adjustment of Kvi_Sum_Limit

The Kvi_sum_limit is the maximum current limit when performing adjustment. Usually the default value can satisfy most applications. However, if the application system has a large resistance or the acceleration is too large, so that the actual current has reached the Kvi_sum_limit current, and at the same time, the actual speed is far less than the target speed. The value of this parameter should be increased. If the output current is prone to saturation, but the saturated output current will cause low frequency oscillations, this parameter should be reduced.

The Kvi_sum_limit should be as small as possible on the basis of satisfying the application. The smaller the Kvi_sum_limit value, the shorter the adjustment time.

Step 4: Adjustment for Speed_fb_N

Feedback filter can reduce noise from the feedback path, eg, encoder resolution noise.

For different applications, the speed feedback filter can be converted to 1st and 2nd order by $Speed_Mode$.

1st order can reduce more noise, but produce less phase shift, allowing the higher Kvi or Kvp .

2nd order filter reduces more noise, but also provide more phase shift, which can limit the Kvi or Kvp .

Usually, if the machine and the load use soft connection, it is recommended to use a 1st order low-pass feedback filter or turn off the feedback filter. If the rigid connection is used or the load is too heavy, the 2nd order low-pass feedback filter could be used. Factory default is a 2nd order low-pass feedback filter, which is suitable for most applications.

If the motor noise is too loud when adjusting the Kvi or Kvp , you can appropriately reduce the speed feedback filter parameter(60F9.05). However, the velocity loop feedback filter bandwidth F must be greater than 2 times of the velocity loop bandwidth. Otherwise, oscillation may result. Speed feedback filter bandwidth $F = \text{speed feedback filter} * 20 + 100$ [HZ].

Step 5: Adjustment of output filter

The output filter is a first order low pass torque filter. It can reduce the high-frequency torque order output by the speed control loop, so as to achieve the purpose of suppressing the resonance of the entire system.

When the output filter is set to 2546Hz (1DEC), it means to close the output filter control. When the system has resonance, the user can try to adjust the DEC value of the output filter setting from small to large to reduce noise.

The output filter frequency can be calculated by the following formula:

$$f = \frac{1}{2 \times \pi \times T_s \times \text{Output_Filter_N}}$$

Output_Filter_N Output filter setting(60F9.15), Unit DEC

Ts Constant 62.5us



Remind

- The larger the DEC value set by the output filter, the stronger the filtering effect.
- Output filter settings [Hz]=2546/[DEC]
- Output filter settings [DEC]=2546/[Hz]

Step 6: Notch Filter Adjustment

A notch filter can suppress the resonance frequency by reducing the gain near the mechanical resonance.

If the resonant frequency is unknown, it can be obtained by flowing method:

Adjust the load so that the system runs in the resonance region, monitor the actual current at resonance on the oscilloscope, and then adjust the notch filter to observe whether the resonance disappears. When the current data at resonance is collected on the software oscilloscope, the period value of adjacent harmonics can be measured by the cursor to calculate the resonance frequency. After collecting multiple sets of harmonic cycles to calculate the average value of the cycles, the resonant frequency can be calculated using the average value of the cycles.

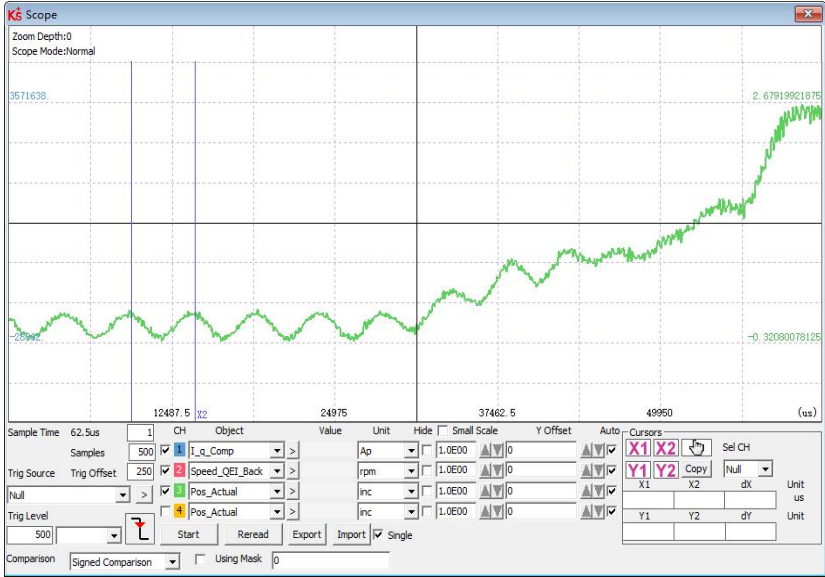
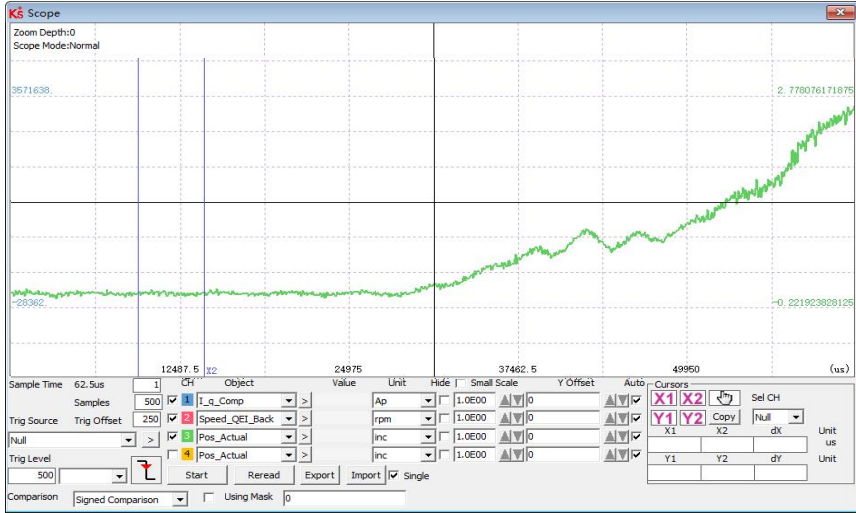
Table 6-3 Notch filter parameter

Internal address	Name	Description	Default	Range
60F903	Notch filter	Used to set the frequency of the internal notch filter to eliminate the mechanical resonance that occurs when the motor drives the machine	550	100-2000
250B01	Notch filter 1			
250B02	Notch filter 2			
250B03	Notch filter 3			
60F904	Notch filter control	Notch filter control of Speed loop Bit0~1: The BCD code composed of two bits determines the filter to be turned on. Bit4: 1 :Indicates FFT analysis using actual current, 0 :Indicates that the target current is used for analysis Bit5: 1: Indicates use actual speed for FFT analysis, 0: Indicates do not use actual speed for FFT analysis Bit.7: 1 indicates that the FFT function is turned on, it will automatically become 0 after the analysis is completed, and it can only be turned on in the enabled state.	0	0-255

(1) Single-point notch filter

When the notch filter control (60F9.04) is set to 0, it indicates to close the notch filter control; when set to 1, it indicates to open a single notch filter, and the frequency of the filter is set by the notch filter (60F9.03) .

Table 6-4 Single notch filter debugging case

Description	Process
<p>Limit output current of drive</p> <p>Use the oscilloscope to collect the current waveform in the resonance region. Note that when collecting the current with the oscilloscope, the sampling period should be set as small as possible, otherwise the resonance waveform may not be collected.</p>	<p>The target current limit is adjusted through the basic operating interface of the servo software</p> 
<p>Observe the resonant frequency with an oscilloscope and calculate the notch filter setting value based on the frequency</p>	<p>The resonant frequency in the figure is 200Hz, the notch filter control is set to 1, and the notch filter is set to 200Hz</p>
<p>After adding a notch filter, collect the actual current waveform again, and adjust it until the current waveform is smooth and free of resonance.</p>	



Note

- In order to prevent machine damage caused by large resonance amplitude during debugging, the value of target current limit can be reduced and then the notch filter can be adjusted.
- During the automatic setting of notch filter, the oscilloscope function cannot be used. After the setting is successful, the oscilloscope automatically switches the acquisition object, and click the reread data to display the FFT result amplitude.

(2)FFT Multi-point Notch Filter

The high order notch filter technology is acquired, the mechanical resonance frequency of the load is measured automatically, and the tuning results are written into filter 0 and filter 1. The FD1x5 and iSMK series drivers open a total of 4 notch filters, filter

0 and filter 1 are automatically adjusted notch filters, filter 2 and filter 3 are manually adjusted notch filters, and the corresponding filters can be turned on/off by the notch filter control.

When the notch filter control (60F9.04) is set to 128DEC, it indicates that the actual current is used for FFT analysis. When the FFT is successfully tuned, the notch filter control bit7 to reset, and the BCD code combined with bit0 and bit1 determines the filter to be turned on.

6.2.2 Position loop setting method

Table 6-5 Position loop parameter list

Internal address	Name	Description	Default	Range
60FB01	Kpp[0]	Set the response bandwidth of the position loop, unit: 0.01Hz	10	0 ~ 327
2FF01A	K_Velocity_FF%	0 means no feedforward, 1000 means 100% feed forward	1000	0 ~ 4000
2FF01B	K_Acc_FF%	This parameter can only be set if the inertia ratio is set correctly. If you do not know the inertia ratio, please directly set the position loop acceleration feedforward (0x60FB03).	/	0-4000
60FB05	Pos_Filter_N	The average of N effective target velocities	1	1~255
2FF00E	Max_Followin_error_16	Maximum following error (6065.00)=100* Maximum following error 16	10000	/
60FB04	Position loop filter order	Set value 1: Use trapezoidal curve mode 3: Use S curve mode	1	1or 3

Position loop tuning steps:

Step 1: Kpp adjustment

Increasing the Kpp can increase the position loop bandwidth to reduce the positioning time and the following error, but if the setting is too large, it will cause noise or even oscillation, and it must be set according to the load conditions. $Kpp = 103 * \text{position loop bandwidth}$. The bandwidth of the position loop cannot exceed the bandwidth of speed loop. It is recommended that the setting value of the position loop bandwidth be less than one quarter of the bandwidth of the speed loop.

Step 2: Kvff adjustment

Increasing the Kvff can reduce the position following error and improve the dynamic response characteristics of the entire system, but it may lead greater overshoot during acceleration and deceleration. When the position command signal is not smooth, reducing the Kvff can reduce the motor oscillation. When the feedforward is set to 0, if only the Kvp is used to position the servo, the in-position time will be longer.

Kvff function can be regarded as the upper controller, such as PLC, has the opportunity to directly control the velocity in position operating mode. In fact, the function will consume part of the speed loop responsiveness, so the setting value needs to match the position loop and velocity loop bandwidth.

The elastic factor of the flexible load, such as pulley, will cause the speed feedforward command loaded to the speed loop to be unsmooth and cause the load to oscillate. In this type of load, the position loop speed feedforward can be appropriately reduced. In a rigid load, if adjusting the Kpp cannot eliminate the vibration generated by the motor during acceleration and deceleration, you can also try to gradually decrease the default 100% feedforward.

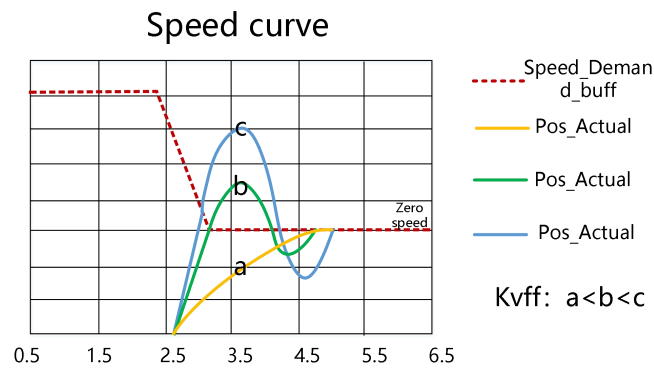


Figure 6-4 Speed step curve after Kvff adjustment

Step 3: Position loop acceleration feedforward adjustment

Users are not advised to adjust this parameter. When the practical application requires very high position loop response, the acceleration feedforward can be adjusted to improve the response performance.

The acceleration feedforward function can be seen as the upper controller has the opportunity to directly control the torque in the position operating mode. This function actually consumes some of the current loop responsiveness, so if the settings do not match the Kvp and velocity loop bandwidth, overshoot and oscillation will occur.

Also, the velocity feed forward to the velocity loop may not be smooth and has some noise signal inside, so a large velocity feed forward value will also amplify the noise.

Kaff can be calculated by following function:

$$\text{ACC_}\% = 6746518 / \text{K_Acc_FF} / \text{Easy_Kload} * 100$$

ACC_% This means what percentage will be used for acceleration feedforward.

K_Acc_FF Kaff(60FB.03), calculates the final internal factor of the feedforward.

**Note**

The smaller the value of the K_Acc_FF parameter, the greater the position loop acceleration feedforward.

Step 4: Smooth filter adjustment

The smoothing filter is a moving average filter. It filters the velocity commands from the velocity generator to make the velocity and position commands smoother. Using this filtering causes velocity and position commands to be delayed in the drive. So for some applications, like CNC, it is better not to use this filter, but to do the smoothing in the CNC.

Smoothing filters reduce machine influence by smoothing commands. Smoothing Filter (60FB.05) defines the time constant of this filter in ms. Under normal circumstances, if the machine system vibrates when starting and stopping, it is recommended to increase the smoothing filter setting.

Step 5: Other adjustment

In position mode (operation mode 1), the position loop command filter control(60FB.04) can be set to 3 to enable the S-curve control. This curve has no command delay and is suitable for long-distance positioning control. When the speed step of the trapezoidal speed curve is large, it will cause a certain impact on the mechanical equipment. The S-shaped curve has better flexibility and smooth acceleration and deceleration, which can effectively overcome the mechanical vibration caused by the sudden change of speed.

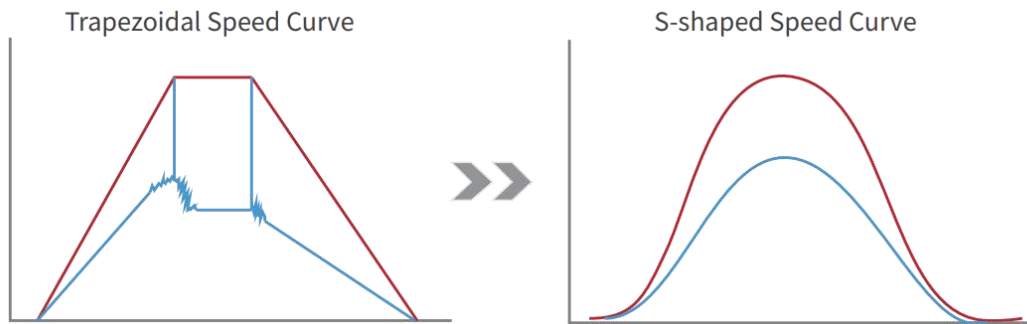


Figure 6-5 S-shaped speed step curve

**Note**

The S-curve is valid only in position mode (operating mode 1)

6.3 Gain switch (Pro mode)

This function is only used for professional !

The drive support 4 sets of PI gain settings. Each set includes Kvp, Kvi, Kpp. The actual PI parameters used are Kvp (x), Kvi (x), and Kpp (x). x=data of PI pointer.

Table 6-6 Gain switching parameter

Internal address	Type	Name	Description	Unit
60F9.01	Unsigned16	Kvp[0]	Gain parameter called when PI pointer is 0	Dec, Hz
60F9.02	Unsigned16	Kvi[0]		Dec
60FB.01	Integer16	Kpp[0]		Dec. Hz
2340.04	Unsigned16	Kvp[1]	Gain parameter called when PI pointer is 1	Dec, Hz
2340.05	Unsigned16	Kvi[1]		Dec
2340.06	Unsigned16	Kpp[1]		Dec. Hz
2340.07	Unsigned16	Kvp[2]	Gain parameter called when PI pointer is 2	Dec, Hz
2340.08	Unsigned16	Kvi[2]		Dec
2340.09	Unsigned16	Kpp[2]		Dec. Hz
2340.0A	Unsigned16	Kvp[3]	Gain parameter called when PI pointer is 3	Dec, Hz
2340.0B	Unsigned16	Kvi[3]		Dec
2340.0C	Unsigned16	Kpp[3]		Dec. Hz
60F9.28	Unsigned8	PI point	Indicates the PI parameter being called	Dec
60F9.09	Unsigned8	Auto PI switch	When the target position/target speed is reached, that is, when bits.Target_reached=1, select the PI parameter, which is suitable for the occasions where different PI parameters need to be used during the motion process and the static state: 0: PI pointer (60F9.28)=0; 1: PI pointer (60F9.28)=1;	Dec

6.3.1 Gain switching method

The driver provides three ways to dynamically select PI control parameters:

Method 1: Switch PI through a digital input port

Configure the function gain switch 0 or/and gain switch 1 at the digital input port, and the value of the PI pointer is the BCD code composed of the input:

Bit0: Gain switch 0

Bit1: Gain switch 1

Table 6-7 Correspondence between gain switching and PI pointer

Gain switch 0 Effective input level	Gain switch 1 Effective input level	Value of PI pointer
1	0	1
0	1	2
1	1	3

Example:



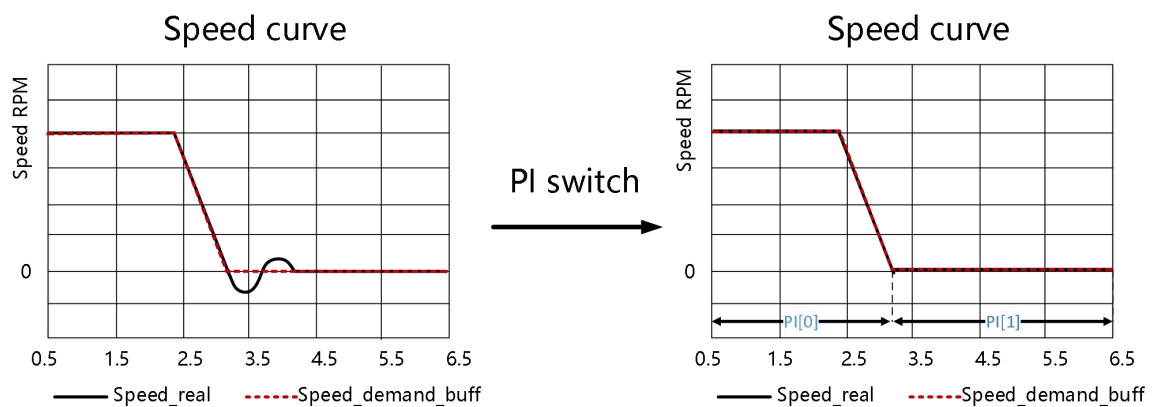
Figure 6-6 Gain switch definition

Gain switch 0 = 1, Gain switch 1 = 0, so PI pointer = 1, Valid PI parameter is Kvp[1], Kvi[1], Kpp[1]

Method 2: Drive auto switch PI

Set auto switch PI (6069.09) = 1: When the motor is running, the PI pointer is 0; when the motor is in the position to or the motor zero speed state, the PI pointer is 1.

Some equipment with large inertia may be affected by inertia or elastic force and vibrate when it decelerates to stop. At this time, switching flexible PI parameters helps to achieve efficient shutdown. Automatic PI switching is suitable for applications where different PI parameters are required for these motors in running and stopped states. If the gain switching function is defined on the digital input port, the automatic gain switching will be invalid.



Method 3: Set PI pointer value directly through communication

6.4 Other factors affecting performance

Control commands created by a controller (e.g. PLC).

- Control commands should be as smooth as possible and must be correct and reasonable. For example, the acceleration in the control command cannot exceed the maximum acceleration that can be produced by the motor torque. By collecting the speed and current step waveforms, during the acceleration process, when the current is saturated and clipped, the acceleration and deceleration can be appropriately reduced or the smoothing filter can be increased.



- The control command should follow the bandwidth limits of the control loop.

Mechanical design

In applications, performance is often limited by the machine. Various factors can affect the final control performance. Control performance will affect the final performance of the machine such as accuracy, responsiveness and stability.

Chapter 7 List of Common Object Parameters



Note

- CANopen address and 232 communication address are the same
- Express register addressing in the form of Index (16-bit address) and Subindex (8-bit sub-address)
- The digit 0x08 indicates that the length of the data stored in this register is 1 Byte, the digit 0x10 indicates that the length of the data stored is 2 Bytes, and the digit 0x20 indicates that the length of the data stored is 4 Bytes
- R: readable, W: writable, S: savable, M: mappable; T: traceable, L: read in the control ring, B: need to save and restart
- A complete CANopen address is in the format of: 60400010 (control word)
- Modbus address is a 4-digit hexadecimal number
- A complete Modbus address format is: 3100 (control word)

Object list

Category	Index	Sub-index	Modbus address	Data type	Name
Category 1 [Input/Output Settings]	2010	01	0810	Unsigned16	Din_Polarity
		02	0820	Unsigned16	Din_Simulate
		03	0830	Unsigned16	Din1_Function
		04	0840	Unsigned16	Din2_Function
		05	0850	Unsigned16	Din3_Function
		06	0860	Unsigned16	Din4_Function
		0A	08A0	Unsigned16	Din_Real
		0D	08D0	Unsigned16	Dout_Polarity
		0E	08E0	Unsigned16	Dout_Simulate
		0F	08F0	Unsigned16	Dout1_Function
		10	0900	Unsigned16	Dout2_Function
		14	0940	Unsigned16	Dout_Real
		18	0980	Unsigned16	Zero_Speed_Window
		19	0990	Unsigned8	Limit_Function
Category 2 [Speed/position setting]	2020	01	0C10	Integer32	Din_Pos0
		02	0C20	Integer32	Din_Pos1
		03	0C30	Integer32	Din_Pos2
		04	0C40	Integer32	Din_Pos3
		05	0C50	Integer32	Din_Speed0
		06	0C60	Integer32	Din_Speed1
		07	0C70	Integer32	Din_Speed2
		08	0C80	Integer32	Din_Speed3
		10	0D00	Integer32	Din_Pos4
		11	0D10	Integer32	Din_Pos5
		12	0D20	Integer32	Din_Pos6
		13	0D30	Integer32	Din_Pos7
		14	0D40	Integer32	Din_Speed4
		15	0D50	Integer32	Din_Speed5
		16	0D60	Integer32	Din_Speed6
		17	0D70	Integer32	Din_Speed7
		0F	0CF0	Unsigned16	Din_Control_Word

Category	Index	Sub-index	Modbus address	Data type	Name
Category 3 [Pulse input Settings]	2508	01	1910	Integer16	Gear_Factor[0]
		02	1920	Unsigned16	Gear_Divider[0]
		03	1930	Unsigned8	PD_CW
		04	1940	Integer32	Gear_Master
		05	1950	Integer32	Gear_Slave
		06	1960	Unsigned16	PD_Filter
		09	1990	Unsigned16	Position_Window_time
		0C	19C0	Integer16	Master_Speed
		0D	19D0	Integer16	Slave_Speed
Category 4 [Error code]	2601	00	1F00	Unsigned16	Erroe_State
	2602	00	2000	Unsigned16	Erroe_State 2
Category 5 [Storage parameter setting]	2FF0	01	2910	Unsigned8	Store_Data
		03	2930	Unsigned8	Store_Motor_Data
Category 6 [Control and status of equipment]	6040	00	3100	Unsigned16	Controlword
	6041	00	3200	Unsigned16	Statusword
Category 7 [Stop mode setting]	605A	00	3400	Integer16	Quick_Stop_Mode
	605B	00	3410	Integer16	Shutdown_Stop_Mode
	605C	00	3420	Integer16	Disable_Stop_Mode
	605D	00	3430	Integer16	Halt_Mode
	605E	00	3440	Integer16	Fault_Stop_Mode
Category 8 [Working mode setting]	6060	00	3500	Integer8	Operation_Mode
Category 9 [Basic parameter setting]	6063	00	3700	Integer32	Pos_Actual
	6065	00	3800	Unsigned32	Max_Following_Error
	6067	00	3900	Unsigned32	Target_Pos_Window
	606C	00	3B00	Integer32	Speed_Real
	6071	00	3C00	Integer16	Target_Torque%
	6073	00	3D00	Unsigned16	CMD_q_Max
	6078	00	3E00	Integer16	I_q
	607A	00	4000	Integer32	Target_Position
	607C	00	4100	Integer32	Home_Offset
	607D	01	4410	Integer32	Soft_Positive_Limit
		02	4420	Integer32	Soft_Negative_Limit
	607E	00	4700	Unsigned8	Invert_Dir
	6080	00	4900	Unsigned16	Max_Speed RPM
	6081	00	4A00	Unsigned32	Profile_Speed
	6083	00	4B00	Unsigned32	Profile_Acc
	6084	00	4C00	Unsigned32	Profile_Dec
	6085	00	3300	Unsigned32	Quick_Stop_Dec
	60F6	08	5880	Integer16	CMD_q
	60FD	00	6D00	Unsigned32	Digital_Inputs
60FF	00	6F00	Integer32	Target_Speed	
Category 10 [Origin mode setting]	6098	00	4D00	Integer8	Homing_Method
	6099	01	5010	Unsigned32	Homing_Speed_Switch
		02	5020	Unsigned32	Homing_Speed_Zero
		05	5050	Unsigned8	Home_Offset_Mode
609A	00	5200	Unsigned32	Homing_Accelaration	
Category 11 [Speed loop parameters]	60F9	01	6310	Unsigned16	Kvp[0]
		02	6320	Unsigned16	Kvi[0]
		05	6350	Unsigned8	Speed_Fb_N
		07	6370	Unsigned16	Kvi/32
		0A	63A0	Integer32	Target_Speed_Window
		14	6440	Unsigned16	Zero_Speed_Time

Category	Index	Sub-index	Modbus address	Data type	Name
Category 12 [Position loop parameter]	60FB	01	6810	Integer16	Kpp[0]
		02	6820	Integer16	K_Velocity_FF
		03	6830	Integer16	K_Acc_FF
		05	6850	Unsigned16	Pos_Filter_N
Category 13 [Alarm parameters]	6410	18	7180	Integer16	Temp_Motor_Ref
		19	7190	Integer16	Temp_Motor
	6510	07	8670	Unsigned16	Voltage_Under
		08	8680	Unsigned16	Chop_Voltage
		09	8690	Unsigned16	Voltage_Over

7.1 Mode and Control (0x6040)

Name	CANopen	Modbus	Command Properties	Data type	Unit	Initial value	Explanation
Control word	60400010	3100	RWLTM	Unsigned16	HEX	0006	0x06: Loose shaft 0x0F: Lock shaft 0x0B: Quick stop, load stop - voltage disconnect 0x2F→3F: Enter the absolute positioning mode 0x4F→5F: Enter relative positioning mode 0x103F: Immediate absolute positioning as target position changes 0x0F-1F: homing 0X86: Error reset
Status word	60410010	3200	RLTM	Unsigned16	HEX	0218	The status byte shows the status of the drive bit0: Ready_on bit1: Switched_on bit2: Operation_enable bit3: Fault bit4: Voltage_enable bit5: Quick_stop bit6: Switchon_disabled bit7: Warning bit8: Internal retention bit9: Remote bit10: Target_reached bit11: Internal limit activation bit12: Pulse response bit13: Following_Error bit14: Commutation_Found bit15: Reference_Found
Operating mode	60600008	3500	RWLM	Integer8	DEC	-4	1: Positioning mode with position ring 3: Speed mode with position loop 4: Torque mode -3: Speed loop(Immediate velocity mode) -4: Pulse mode 6: Homing mode 7: Motion interpolation based on CANopen

Absolute/ relative position control selection	20200F10	0CF0	RWSL	Unsigned16	HEX	002F	When the "Drive Enable" function is configured to Din and the corresponding Din valid input is 1, the "Control word" (6040.00) is set to this value; 0x2F: Absolute position control 0x4F: Relative position control
---	----------	------	------	------------	-----	------	--

7.2 Metrical data

Name	CANopen	Modbus	Command Properties	Data type	Unit	Initial value	Explanation
Actual position	60630020	3700	RLTM	Integer32	inc	0	Actual motor position
Actual current value	60780010	3E00	RLTM	Integer16	Ap	0.00	Rated current
Input port status	60FD0020	6D00	RLTM	Unsigned32	HEX	0	bit0: negative limit switch bit1: positive limit switch bit2: home switch bit4: interlock
Actual speed	606C0020	3B00	RLTM	Integer32	rpm	0.00	rpm



Note

0x606C0020, The unit conversion method is $DEC = [(RPM * 512 * \text{Encoder resolution}) / 1875]$

7.3 Target object (0x607A)

Name	CANopen	Modbus	Command Properties	Data type	Unit	Initial value	Explanation
Velocity position direction control	607E0008	4700	RWSL	Unsigned8	DEC	0	Run polarity reversal 0: Counterclockwise is the positive direction 1: Clockwise is the positive direction
Target position	607A0020	4000	RWLTM	Integer32	inc	0	The target position in position mode 1, if the control word is set to start motion, transitions to the valid command position inc
Trapezoidal velocity	60810020	4A00	RWLTM	Unsigned32	rpm	0.00	Trapezoidal velocity (rpm) in operating mode 1
Target speed	60FF0020	6F00	RWLTM	Integer32	rpm	0.00	Target speed in mode 3 and -3,
Max velocity limit	60800010	4900	RWL	Unsigned16	rpm	5000	Default: 5000rpm
Trapezoidal acceleration	60830020	4B00	RWSLTM	Unsigned32	rps/s	100.00	Default: 100rps/s
Trapezoidal deceleration	60840020	4C00	RWSLTM	Unsigned32	rps/s	100.00	Default: 100rps/s

Target torque	60710010	3C00	RWL	Integer16	%	0.00	Torque command in torque mode, the percentage of target torque to rated torque
Target current	60F60810	5880	RWLTM	Integer16	Ap	0.00	Current command in torque mode
Target current limit	60730010	3D00	RWSLTM	Unsigned16	Ap	48.00	Current instruction maximum

**Note**

- Velocity address: 0x60810020, 0x60800020, 0x60FF0020
- The unit conversion method is $DEC = [(rpm * 512 * \text{encoder resolution}) / 1875]$
- Acceleration and deceleration address: 0x60830020, 0x60840020,
- The unit conversion method is $DEC = [(rps/s * 65536 * \text{encoder resolution}) / 4000000]$
- Current address: 0x60710010, 0x60730010
- The unit conversion method is $1Arms = [2048 / (I_{peak} / 1.414)] DEC$ Note: I_{peak} is peak current (6510.03)

7.4 Multi-segment position/Multi-segment speed (0x2020)

Name	CANopen	Modbus	Command Properties	Data type	Unit	Initial value	Explanation
Multi-stage position control 0	20200120	0C10	RWSL	Integer32	DEC	0	Din position [x] is meaningful only if at least one of Din Position Index 0, Din Position Index 1, or Din Position Index 2 is configured to Din; x=0~7, is the BCD code composed of the three indexes; bit0: Din Location index 0 bit1: Din Location index 1 bit2: Din Location index 2 When one of the bits is configured to Din, the unconfigured bits are equal to 0
Multi-stage position control 1	20200220	0C20	RWSL	Integer32	DEC	0	
Multi-stage position control 2	20200320	0C30	RWSL	Integer32	DEC	0	
Multi-stage position control 3	20200420	0C40	RWSL	Integer32	DEC	0	
Multi-stage Position Control 4	20201020	0D00	RWSL	Integer32	DEC	0	
Multi-stage Position Control 5	20201120	0D10	RWSL	Integer32	DEC	0	
Multi-stage position control 6	20201220	0D20	RWSL	Integer32	DEC	0	
Multi-stage position control 7	20201320	0D30	RWSL	Integer32	DEC	0	
Multi-stage speed control 0	20200520	0C50	RWSL	Integer32	rpm	0.00	The speed instruction of the driver is specified by the DIN speed [x], where the x is a BCD code composed of the following signals: bit 0: Din speed index 0; bit 1: Din speed index 1; bit 2: Din Speed index 2; The situation where all the medians are 0 cannot occur;
Multi-stage speed control 1	20200620	0C60	RWSL	Integer32	rpm	0.00	

Name	CANopen	Modbus	Command Properties	Data type	Unit	Initial value	Explanation
Multi-stage speed control 2	20200720	0C70	RWSL	Integer32	rpm	0.00	
Multi-stage speed control 3	20200820	0C80	RWSL	Integer32	rpm	0.00	
Multi-stage speed control 4	20201420	0D40	RWSL	Integer32	rpm	0.00	
Multi-stage speed control 5	20201520	0D50	RWSL	Integer32	rpm	0.00	
Multi-stage speed control 6	20201620	0D60	RWSL	Integer32	rpm	0.00	
Multi-stage speed control 7	20201720	0D70	RWSL	Integer32	rpm	0.00	

7.5 Performance object (0x6065)

Name	CANopen	Modbus	Command Properties	Data type	Unit	Initial value	Explanation
Max following error	60650020	3800	RWSLM	Unsigned32	inc	524288	Following error value alarm value Default 524288inc
target location window	60670020	3900	RWSL	Unsigned32	inc	327	"Target location reached" target range, Default 10inc
reach position time window	25080910	1990	RWSLTM	Unsigned16	ms	10	Target (location.velocity) reach time window , Determine the reach position signal together with 0x60670020
Reach speed window	60F90A20	63A0	RWSL	Integer32	inc/16s	178956	The error window when the actual speed reaches the target speed or trapezoidal speed, and determines the reach speed signal together with 0x60F91C20
Zero speed output speed window	20101810	0980	RWSL	Unsigned16	inc/ms	3.00	Error window when actual speed is 0
Zero speed output time	60F91410	6440	RWSL	Unsigned16	ms	10.00	Zero-speed output speed window 0x20101810 After reaching the set range, it takes a period of time to output the zero-speed signal, and the time is determined by the zero-speed output time
Positive setting of soft limit	607D0120	4410	RWSL	Integer32	DEC	0	Soft limit positive setting
Soft limit negative setting	607D0220	4420	RWSL	Integer32	DEC	0	Soft limit negative setting
Limit function definition	20101908	0990	RWSL	Unsigned8	DEC	1	Used to set the action after the limit is reached 0: If there is a limit after finding the origin, it will alarm 1: do nothing

7.6 Homing control (0x6098)

Name	CANopen	Modbus	Command Properties	Data type	Unit	Initial value	Explanation
Homing mode	60980008	4D00	RWSLM	Integer8	DEC	0	Homing function Refer origin control chapter
Origin turning signal speed	60990120	5010	RWSLTM	Unsigned32	rpm	300.00	After touching the trigger event, the speed of homing process (rpm)
Origin signal speed	60990220	5020	RWSLTM	Unsigned32	rpm	100.00	Speed when starting to find the origin
Homing acceleration	609A0020	5200	RWSL	Unsigned32	rps/s	50.00	Acceleration when homing process unit: rps/s
Origin offset	607C0020	4100	RWSLTM	Integer32	inc	0	Offset value after homing unit: inc
Origin Offset Mode	60990508	5050	RWSL	Unsigned8	DEC	0	Origin Offset Mode Control 0: run to the origin offset position, the actual position is displayed as 0 1: Run to the event trigger point, after the end the actual position will become: - Origin offset

7.7 Speed loop parameter (0x60F9)

Name	CANopen	Modbus	Command Properties	Data type	Unit	Initial value	Explanation
Kvp	60F90110	6310	RWSL	Unsigned16	DEC	4	The larger the value, the stronger the gain, but it may cause the motor howling
Kvi	60F90210	6320	RWSL	Unsigned16	DEC	0	The larger the value, the stronger the gain, but it may cause the motor howling
Kvi/32	60F90710	6370	RWSL	Unsigned16	DEC	2	Kvi's 1/32
Output filter	60F90508	6350	RWSL	Unsigned8	Hz	240	velocity output filter of velocity loop $BW = \text{Speed_Fb_N} * 20 + 100$ [Hz]

7.8 Position loop parameter (0x60FB)

Name	CANopen	Modbus	Command Properties	Data type	Unit	Initial value	Explanation
kpp 0	60FB 0110	6810	RWSL	Integer16	Hz	10.00	Scale value of the position loop
kvff	60FB0210	6820	RWSL	Integer16	%	100.00	Position loop speed feedforward
kaff	60FB0310	6830	RWSL	Integer16	DEC	32767	Acceleration feedforward for position loop
Smoothing filter	60FB0510	6850	RWSL	Unsigned16	DEC	1	Modify in the disabled state

7.9 Input/output port parameter (0x2010)

Name	CANopen	Modbus	Command Properties	Data type	Unit	Initial value	Explanation
Digital input 1	20100310	0830	RWSL	Unsigned16	HEX	0000	Refer to the function definition below
Digital input 2	20100410	0840	RWSL	Unsigned16	HEX	0000	
Digital input 3	20100510	0850	RWSL	Unsigned16	HEX	0000	
Digital input 4	20100610	0860	RWSL	Unsigned16	HEX	0000	
Digital output 1	20100F10	08F0	RWSL	Unsigned16	HEX	0001	
Digital output 2	20101010	0900	RWSL	Unsigned16	HEX	0002	
Input port status	20100A10	08A0	RLTM	Unsigned16	HEX	0000	bit0: Din1 bit1: Din2 bit2: Din3 bit3: Din4
Output port status	20101410	0940	RLTM	Unsigned16	HEX	000A	bit0: Dout1 bit1: Dout2
Change the input signal polarity definition	20100110	0810	RWSL	Unsigned16	HEX	FFFF	0: Turn off; 1: Turn on bit0: Din1 bit1: Din2 bit2: Din3 bit3: Din4 bit4: Din5 bit5: Din6 bit6: Din7 bit7: Din8 Default 0xFF
Polarity definition of output port	20100D10	08D0	RWSLTM	Unsigned16	HEX	FFFF	Polarity definition of output port
Input port signal simulation	20100210	0820	RWL	Unsigned16	HEX	0000	bit0: Din1 bit1: Din2 bit2: Din3 bit3: Din4 bit4: Din5 bit5: Din6 bit6: Din7 bit7: Din8
Output port signal simulation	20100E10	08E0	RWLM	Unsigned16	HEX	0000	bit0: Dout1 bit1: Dout2 bit2: Dout3 bit3: Dout4 bit4: Dout5



Note

Definition of digital input function (hexadecimal)	Output port definition (hexadecimal)
0001: Enable	0001: Ready
0002: Reset errors	0002: Error
0004: Operate mode control	0004: Motor position reached
0008: Kvi off	0008: Motor zero speed
0010: Positive limit	0010: Motor brake
0020: Negative limit	0020: Motor speed reached
0040: Home signal	0040: Index signal appears
0080: Invert direction	0080: Speed limit
0100: Din speed index 0	0100: Driver enabled
0200: Din speed index 1	0200: Position limit
0400: Din position index 0	0400: Home found
0800: Din position index 1	0800: Torque reached limit
1000: Quick stop	1000: Multi-function signal 0
2000: Start homing	2000: Multifunction Signal 1
4000: Activate command	4000: Multifunction Signal 2
8001: Din speed index 2	8001: STO active
8002: Din position index 2	
8004: Multi-function input signal 0 (for setting multi-stage electronic gear ratio)	
8008: Multi-function input signal 1	
8010: Multi-function input signal 2	
8020: Gain switching 0	
8040: Gain switching 1	
8080: Maximum current toggle input switch	
8100: Motor error	
8200: Pre-enable (The IO port must have an enable signal, otherwise it will alarm, which is used in some occasions where the machine needs to be determined before running the machine)	
8400: Fast capture 1	
8800: Fast capture 2	

The digital input function is described in the following table:

Input function	Description
Enable	Drive enable 1: Control word = Din Control word selection (2020.0F) 0: Control word = 0x06
Reset error	The reset error bit (bit7) in the control word = 1
Operating mode control	Working mode selection 1: Work mode = Work mode Select 1 (2020.0E). The default value is -4 0: Working mode = The working mode is set to 0 (2020.0D). The default value is -3
Kvi off	1: Turn off the speed loop integral gain 0: The set value of the speed loop integral gain is valid See Chapter 6 for more information
Positive limit	Normally closed positive/negative limit switch signal input
Negative limit	0: In the limit, the limit is activated and the corresponding direction of movement is prohibited
Home signal	Origin switch signal can be used when finding the origin
Invert direction	In speed and torque mode, the speed command can be reversed
Din speed index 0	Din speed index in Din speed mode
Din speed index 1	
Din speed index 2	
Din position index 0	Din position index in Din location mode
Din position index 1	

Din position index2	
Quick stop	Set control word bit bit2=0 to enable emergency stop. To re-enable after emergency stop, you need to first set the control word to 0x06 and then to 0x0F (if the input port is configured with drive enable, you only need to trigger the enable signal again).
Start homing	Start to find the origin signal, must be used with the driver enabled. When the origin is found, the working mode switches back to the working mode before the origin is found
Activate command	Activate position instructions, such as the control word from 0x2F to 0x3F
Multi-function input signal 0	Used to select the electronic gear ratio, the electronic gear molecule and the electronic gear denominator are determined by a BCD code composed of multifunctional inputs. The actual electronic gear ratio used is the electronic gear molecule [x], the electronic gear denominator [x], and x is the BCD code composed of multi-function input: Bit0: Multi-function input 0 Bit1: Multifunction input 1 Bit2: Multi-function input 2
Multi-function input signal 1	
Multi-function input signal 2	
Gain switching input signal 0	The PI pointer (60F9.28) is determined by the BCD code consisting of gain switch 0 and gain switch 1, which also determines the index of Kvp, Kvi, and Kpp, as detailed in Section 6.2
Gain switching input signal 1	
Motor error	If an external error occurs (for example, the motor itself is too hot), the error signal can be transmitted to the driver through the input port
Fast Capture 1	The fast capture function is used to capture the actual position (6063.00) data when the corresponding input signal edge arrives, with the fastest response time not exceeding 2ms.
Fast Capture 2	When the input function is configured as fast capture 1, if the rising edge of the input port comes, the rising edge capture state 1 will change to 1, and the actual position will be stored in the rising edge position 1. If the input falling edge arrives, the falling edge capture state 1 changes to 1, and the actual position is stored in falling edge position 1. Once rising edge capture state 1 or falling edge capture state 1 changes to 1, the user needs to reset them to 0 for the next capture, otherwise the next position will not be captured. Quick Capture 2 is used in a similar way to Quick Capture 1.
Pre-enable	For security reasons, a pre-enable signal can be used to represent whether the drive is ready, 1: indicates that the drive is ready and can be enabled. 0: indicates that the drive is not ready and cannot be enabled
Cear pulse	Clear gear front pulse data that has been received but not executed by the drive
Pause	1: The motor is suspended, bit8 = 1 in the control word 0: The motor continues to execute unfinished instructions
Positive trim	Position fine-tuning data in positive direction in active pulse mode
Negative trim	Position fine-tuning data in negative direction in active pulse mode

The digital output function is described in the following table:

Output function	Description
Ready	The drive is ready and can be enabled
Error	Driver failure alarm
Motor position reached	In position mode, when the difference between the actual position and the target position is less than the target position window (6067.00), and the duration is greater than or equal to the position window time (6068.00), the output position to the function is displayed
Motor zero speed	When the absolute value of the actual velocity -ms (60F9.1A) is less than or equal to the zero velocity window (2010.18), and the duration is greater than or equal to the zero velocity time (60F9.14), the zero velocity function is output
Motor brake	The motor brake control output signal can be used to connect an external relay that controls the motor lock. If the brake motor is used, this function must be set, otherwise it will damage the motor. An effective output of green indicates that the lock is opened, and an effective output of gray indicates that the lock is closed.
Motor speed reached	Output speed to function when the speed error (60F9.1C) is less than the speed to window (60F9.0A)
Index signal occurrence	Motor index signal appears
Speed limit reached	In torque mode, the actual speed reaches the maximum speed limit (607F.00)

Driver enabled	Drive is enabled. Motor locks shaft
Position limited	Positive-negative position limit medium
Home found	Home found
Torque reached limit	When the actual torque (60F5.08) reaches the baseline (60F5.06) and the duration exceeds the filtering time (60F5.07), the output torque reaches the limit. If the torque reaches the baseline (60F5.06) is set to 0, the torque reaches the limit detection is not enabled.
Multi-function signal 0	Din multi-segment position control for position-to-output functions is described in Chapter 5, Section 5.4.1.1
Multifunction signal 1	
Multifunction signal 2	

7.10 Pulse input parameters (0x2508)

Name	CANopen	Modbus	Command Properties	Data type	Unit	Initial value	Explanation
Electronic gear molecule 0	25080110	0x1910	RWSLTM	Integer16	DEC	1000	Electronic gear molecule 0
Electronic gear denominator 0	25080210	0x1920	RWSLTM	Unsigned16	DEC	1000	Electronic gear denominator 0
Pulse mode control	25080308	0x1930	RWSLB	Unsigned8	DEC	1	0: Double pulse mode 1: Pulse direction mode 2: Incremental encoder mode 10:422 Double pulse mode 11: 422 pulse direction mode 12: 422 Incremental encoder mode(After the data change takes effect, the storage control parameters must be restarted.)
Number of input pulses before electronic gear	25080420	0x1940	RWLTM	Integer32	DEC	0	Number of input pulses before electronic gear
Number of input pulses after electronic gear	25080520	0x1950	RWL	Integer32	DEC	0	Number of input pulses after electronic gear
Pulse filter parameters	25080610	0x1960	RWSL	Unsigned16	DEC	3	Pulse filter parameters
Pulse frequency before gear	25080C10	0x19C0	RLTM	Integer16	DEC	0	Pulse frequency before gear (pulse/mS)
Pulse frequency after gear	25080D10	0x19D0	RLT	Integer16	DEC	0	Pulse frequency after gear (pulse/mS)

7.11 Parameter for storage (0x2FF0)

Name	CANopen	Modbus	Command Properties	Data type	Unit	Initial value	Explanation
Storage control parameters	2FF00108	2910	RWL	Unsigned8	DEC	0	1: Store all configuration parameters set 10: Initialize all configuration parameters Note: The control loop parameters are stored, excluding motor parameters.

Store motor parameters set	2FF00308	2930	RWL	Unsigned8	DEC	0	1: Store all motor parameters set
----------------------------	----------	------	-----	-----------	-----	---	-----------------------------------

7.12 Error code (0x2601)

Name	CANopen	Modbus	Command Properties	Data type	Unit	Initial value	Explanation
Error state	26010010	1F00	RLTM	Unsigned16	HEX	0408	Real-time alarm error status bit 0: Extended Error bit 1: Encoder ABZ/not connected bit 2: Encoder UVW/ Encoder internal bit 3: Encoder Counting/Encoder CRC bit 4: Driver temperature bit 5: Over voltage bit 6: Under voltage bit 7: Over current bit 8: Chop Resistor bit 9: Position Following bit 10: Low logic voltage bit 11: Motor or Driver Ilt bit 12: Over frequency bit 13: Motor temperature bit 14: Motor commutation bit 15: EEPROM data
Error state 2	260200	2000	RLTM	Unsigned16	HEX	0000	Error state 2 bit 0: Current Sensor bit 1: Watch dog bit 2: Wrong interrupt bit 3: MCU ID bit 4: Motor configuration Bits 5 to 7: reserved bit 8: External enable bit 9: Positive limit bit 10: Negative limit bit 11: SPI internal bit 12: Abort connection bit 13: Closed loop direction bit 14: Master ABZ bit 15: Master counting

7.13 Stop mode

Name	CANopen	Modbus	Command Properties	Data type	Unit	Initial value	Explanation
Quick stop mode	605A0010	3400	RWSL	Integer16	DEC	0	Encountered limit switch, emergency stop switch, or control word is 0x000B 0: stop without control 1: stop by using ramp, then switch off 2: stop by using quick stop deceleration, then switch off 5: stop with profile deceleration, stay in quick stop active 6: stop with quick stop deceleration, stay in quick stop active 18: using motor winding for brake even encoder is wrong

Shutdown mode	605B0010	3410	RWSL	Integer16	DEC	0	Shutdown stop mode (Drive enable cancel) 0: stop without control 1: stop by using ramp, then switch off 2: stop by using quick stop deceleration, then switch off 18: using motor winding for brake even encoder is wrong
Disable stop mode	605C0010	3420	RWSL	Integer16	DEC	0	0: stop without control 1: stop by using ramp, then switch off 2: stop by using quick stop deceleration, then switch off 18: using motor winding for brake even encoder is wrong
Pause mode	605D0010	3430	RWSL	Integer16	DEC	1	Control word bit8 is set to 1 The motor is paused and enabled 1: stop by current ramp 2: stop by quick stop deceleration
Error stop mode	605E0010	3440	RWSL	Integer16	DEC	0	0: stop without control 1: stop by using ramp, then switch off 2: stop by using quick stop deceleration, then switch off 18: using motor winding for brake even encoder is wrong
Trapezoidal deceleration	60840020	4C00	RWSLTM	Unsigned32	rps/s	100.00	Working Mode Deceleration in modes 1 and 3
Quick stop deceleration	60850020	3300	RWSL	Unsigned32	rps/s	610.00	Deceleration for quick stop

7.14 Alarm parameter

Name	CANopen	Modbus	Command Properties	Data type	Unit	Initial value	Explanation
Temp_Motor_Ref	64101810	7180	RWSL	Integer16	°C	100	The default alarm point for the temperature is 100 ° C
Temp_Motor	64101910	7190	RLT	Integer16	°C	-	When the motor is not connected to the temperature sensor or the temperature sensor is abnormal, the motor temperature will be displayed at -40°C
Voltage_Under	65100710	8670	RWHP	Unsigned16	V	18	Drive low voltage alarm point
Chop_Voltage	65100810	8680	RWHP	Unsigned 16	V	63	Driver chopper voltage point
Voltage_Over	65100910	8690	RWHP	Unsigned 16	V	70	Drive overvoltage alarm point



Note

The iSMK series comes with a temperature sensor by default

7.15 Other Parameter

Name	CANopen	Modbus	Command Properties	Data type	Unit	Initial value	Explanation
Use the internal motor library	30410608	-	RWSL	Unsigned8	DEC	2	0: The driver automatically reads the motor model from the encoder, using the corresponding motor parameters in the driver's motor library 1: The user enters the motor model manually and uses the motor parameters corresponding to the motor library in the drive 2: Read and use the saved motor parameters in the encoder (factory default)
Device restart	2FFF0010	2F00	RW	Unsigned16	HEX	-	Start bootloader 55AA: start bootloader AA55: restart drive
Analog increment	64101F10	-	RWSL	Integer16	DEC		>0: when the encoder is communication type, the simulated resolution of incremental encoder supports 4000, 8000, 10000 incremental encoder data. 0: Disable the simulated incremental encoder, and the feedback resolution refer to motor' default. Note: After setting the analog increment, click "Save motor parameters" to save, and it will take effect after restarting. Because the resolution has changed, you must re-initialize the control parameters and save them again for the restart to take effect

Chapter 8 RS485 Communication

8.1 RS485 cable connection

FD1X5 series servo drive RS485 port supports the 232 protocol and Modbus protocol, which can be used to modify the internal parameters of the servo and monitor the servo state. The default baud rate of FD1X5 is 38400 and Modbus is used by default. Figure 8-1 shows the connection diagram.

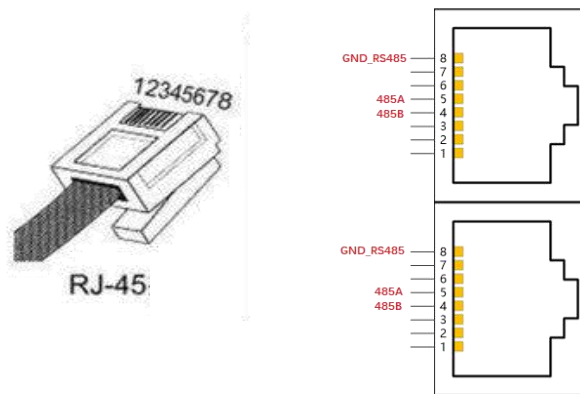


Figure 8 - 1 RS485 interface and definition of FD1X5

iSMK series servo drive RS485 port supports the 232 protocol and Modbus protocol, which can be used to modify the internal parameters of the servo and monitor the servo status. The default baud rate of iSMK 485 is 115200 and the default protocol is 232. Figure 8-2 shows the connection diagram.

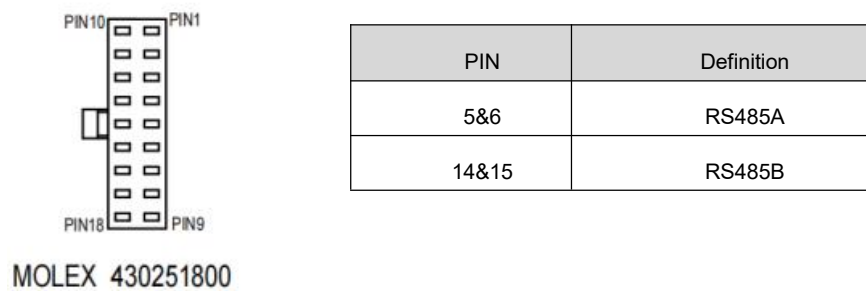


Figure 8 - 2 RS485 ports and definitions for iSMK

→ Note

1. The device station ID and baud rate take effect only after the drive is restarted.
2. When the communication is unstable when connecting the host computer with the baud rate, reduce the communication baud rate and reconnect the software for debugging.
3. The driver has added the function of switching the 232 protocol through modbus, the internal address is 6510 0C, and the corresponding modbus address is mapped to 0X86C0, when the 485 interface uses the Modbus protocol, it can be immediately switched to the 232 protocol by sending the command (Take ID = 1 as an example): 01 06 86 C0 00 01 61 7E can be switched to the host computer immediately, or you can

send 01 06 86 C0 00 03 E0 BF (232 protocol, effective after saving and restarting) 01 06 29 10 00 01 41 93 (store control parameters), and then restart the machine to connect with the host computer.

4. If the iSMK and FD1X5 fail to connect to the host computer using the RS485 communication protocol, it may be caused by MODBUS being selected as the communication protocol. You can send MODBUS instructions according to the third point above to replace the MODBUS protocol with 232 protocol and then reconnect to the host computer.

8.2 RS485 communication parameters list

Internal address	Name	Meaning	Default
100B0010	Device station number	Driver station number	1
2FE20010	RS485 baud rate	Set the baud rate of the RS485 port (Modbus address: 0X2600) Set value Baud rate 1080———9600 540———19200 270———38400 90———115200 Note: Need to save and restart.	iSMK:90 FD1X5:270
65100C08	RS485 Communication protocol selection	bit0:0: Using MODBUS protocol 1: using RS232 communication protocol bit1:0: Changes to bit0 take effect immediately. 1: Changes to bit0 take effect after the storage restarts	iSMK:1 FD1X5:0
65100E10	RS485 mode	Data bit =8, stop bit =1, no parity check	Fixed value
65100B08	RS232 class communication	RS232 level communication control (Modbus address: 0X86B0) 0:1 to 1 communication 1: Cascade communication	0

8.3 MODBUS RTU protocol

FD1X5 and iSMK servos support the MODBUS RTU communication protocol, and their internal objects are discontinuous 16-bit data registers (mapped to 4X when read and written by the upper computer). The format of the message is as follows:

Target station	Function code	Data	CRC check code
1 Byte	1 Byte	N Byte	2 Byte

8.3.1 Modbus common function codes introduction

Function code 0x03: Read data register

Request format:

Target station	Function code	Modbus address		Read byte		CRC
		High Byte	Low byte	High Byte	Low byte	
1 Byte	03	1 Byte	1 Byte	1 Byte	1 Byte	2 Byte

Correct response:

Target station	Function code	Return bytes	Register data		CRC
			High Byte	Low byte		
1 Byte	03	1 Byte	1 Byte	1 Byte	2 Byte

**Note**

If a response error such as the address does not exist, the returned function code is 0x81

Function code 0x06: Write single data register

Request format:

Target station	Function code	Modbus address		revise content		CRC
		High Byte	Low byte	High Byte	Low byte	
1 Byte	06	1 Byte	1 Byte	1 Byte	1 Byte	2 Byte

Response format: If the setting is successful, the original text will be returned.

**Note**

If the written data is out of range, the address does not exist, and the response to read-only data operations is wrong, the returned function code is 0x86.

Function code 0x10: Write multi-holding register

Request format:

Target station	Function code	Modbus address	Data length (word)		Number of bytes of data written (byte)	Low level data		High level data		CRC
			High Byte	Low byte		High Byte	Low byte	High Byte	Low byte	
1 Byte	10	2Byte	1Byte	1Byte	1Byte	1Byte	1Byte	1Byte	1Byte	2Byte

Correct response:

Target station	Function code	Modbus address	Data length (word)		CRC
			High Byte	Low byte	
1 Byte	10	2Byte	1Byte	1Byte	2Byte

**Note**

If the written data is out of range, the address does not exist, or the response to read-only data operations is incorrect, the returned function code is 0x90.

Example: Send packet 01 10 6F 00 00 02 04 55 55 00 08 1A 47

Message meaning:

01—ID number

10—Function code, write multiple WORD

6F 00—The modbus address of the servo writable object "target speed" 60FF0020, the data length is 2 WORD;

00 02—write 2 WORD

04—Data length is 4 Byte (2 WORD);

55 55 00 08—Write data in hexadecimal 00085555, decimal 546133, converted to 30RPM;

1A 47—Check code

8.3.2 Modbus packet Example

When using Kincoservo 3 software, there are two ways to obtain Modbus address information:

1. Click **Help** → **Object Dictionary** on the menu bar. The current Modbus address will be displayed in the help box to the right of the corresponding variable name.

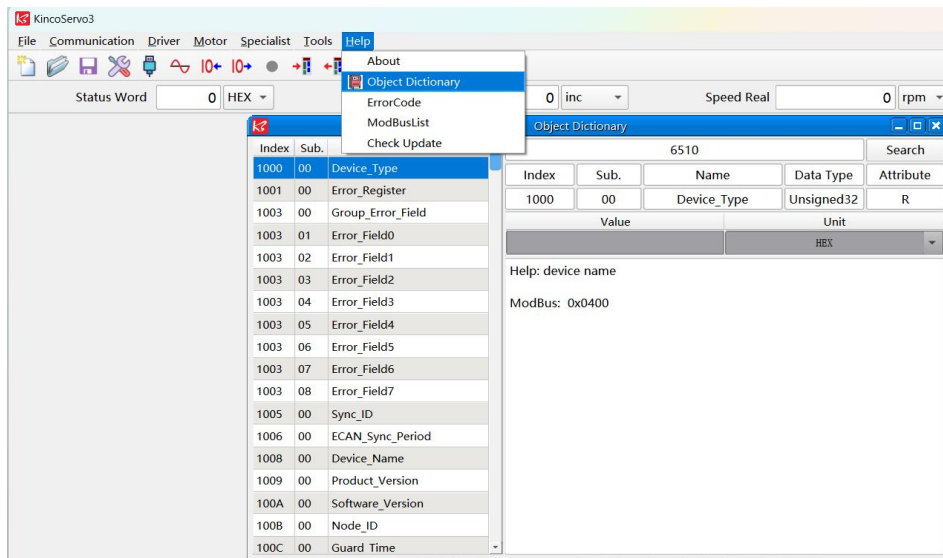


Figure 8-3 Object dictionary interface

2. Click **Help** → **Modbus List** on the menu bar. the complete Modbus address information of all parameters will be displayed.

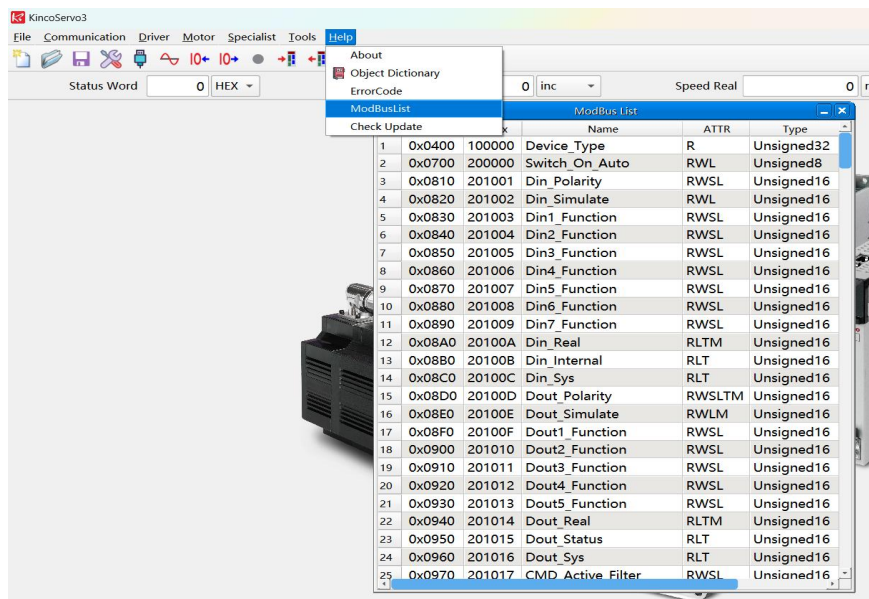


Figure 8-4 ModbusList interface

The following is an example of sending packets in different modes. The station number is 1.

Table 8-1 Message format

Internal address	Modbus address	Name	Note	Message (ID=1)
60600008	3500	Operate mode	Operate mode is 3	01 06 35 00 00 03 C6 07
60FF0020	6F00	Target speed	Speed 150RPM	01 10 6F 00 00 02 04 F5 C3 00 28 D9 B3
60400010	3100	Control word	Enable to write F	01 06 31 00 00 0F C7 32
60410010	3200	Statu word	Read drive status	01 03 32 00 00 02 CA B3
Homing control mode (control word first F then 1F)				

Internal address	Modbus address	Name	Value	Message (ID=1)
60400010	3100	Control word	F	01 06 31 00 00 0F C7 32
60600008	3500	Operate mode	6	01 06 35 00 00 06 06 04
60980008	4D00	Homing mode	33	01 06 4D 00 00 21 5E BE
60990120	5010	Homing transition signal speed	200RPM	01 10 50 10 00 02 04 9D 03 00 36 57 98
60990220	5020	Homing signal speed	150RPM	01 10 50 20 00 02 04 F5 C3 00 28 CE 5A
60400010	3100	Control word	1F	01 06 31 00 00 1F C6 FE
01 03 32 00 00 02 CA B3 Read the status word. C037 indicates that the origin is found (bit15 set to 1)				
Position control mode (control word absolute positioning first 2F then 3F relative positioning first 4F then 5F, 103F update immediately)				
Internal address	Modbus address	Name	Value	Message (ID=1)
60400010	3100	Control word	F	01 06 31 00 00 0F C7 32
60600008	3500	Operate mode	1	01 06 35 00 00 01 47 C6
607A0020	4000	Target position	50000inc	01 10 40 00 00 02 04 C3 50 00 00 FE 39
60810020	4A00	Trapezoid speed	200RPM	01 10 4A 00 00 02 04 55 55 00 08 BC D6
60830020	4B00	Trapezoidal acceleration	610.352rps/s	Use default value
60840020	4C00	Trapezoidal deceleration	610.352rps/s	Use default value
60400010	3100	Control word	2F	01 06 31 00 00 2F C6 EA
		Variable name	3F(Absolute positioning)	01 06 31 00 00 3F C7 26
		Control word	4F	01 06 31 00 00 4F C6 C2
		Operate mode	5F(Relative positioning)	01 06 31 00 00 5F C7 0E
01 03 32 00 00 02 CA B3 Reads the status word. D437 indicates the location rechah(bit10 set to 1)				
Speed control mode				
Internal address	Modbus address	Name	Value	Message (ID=1)
60600008	3500	Operate mode	3	01 06 35 00 00 03 C6 07
60FF0020	6F00	Target position	30RPM	01 10 6F 00 00 02 04 55 55 00 08 1A 47
60400010	3100	Control word	F	01 06 31 00 00 0F C7 32
60830020	4B00	Trapezoidal acceleration	610.352rps/s	Use default value
60840020	4C00	Trapezoidal deceleration	610.352rps/s	Use default value



Note

In communication mode, data is transmitted in hexadecimal format.

Table 8 - 2 Unit conversion relation

Name	Engineering unit	Internal unit	Conversion relation
Speed	rpm	DEC	$DEC=[(RPM*512*Encoder\ resolution)/1875]$
Acceleration	r/s ²	DEC	$DEC=[(R/S^2*65536*Encoder\ resolution)/4000000]$
Current	A	DEC	$1Arms=[2048/(Ipeak/1.414)]DEC$

Note: The encoder resolution is 65536, and the driver Ipeak is shown in **section 1.2**

8.4 RS232 communication protocol

8.4.1 RS232 transport protocol

iSMK and FD1X5 series driver RS-232C communication strictly follow the master/slave station protocol, the host computer can send any data to the driver. The drive is set to an address that calculates this data and replies with a return value.

The transport protocol used by RS232 uses a fixed ten-byte packet format:

Byte 0	Byte 1	Byte 2	Byte 3	Byte 4	Byte 5	Byte 6	Byte 7	Byte 8	Byte 9
Driver ID	Data								CHKS

Host send:

Byte 0	Byte 1	Byte 2	Byte 3	Byte 4	Byte 5	Byte 6	Byte 7	Byte 8	Byte 9
Driver ID	Host send data								CHKS

Servo send/host receive:

Byte 0	Byte 1	Byte 2	Byte 3	Byte 4	Byte 5	Byte 6	Byte 7	Byte 8	Byte 9
Driver ID	Host received data								CHKS

Key points:

The calculation process of the check code CHKS takes 01 40 F0 2F 09 00 00 00 00 97 (this command is to read the target speed of the slave station 2FF00910) as an example, the last 0x97 is the check code, which is calculated by LRC check (vertical redundancy check).

The manual calculation process is as follows: $01 \wedge 40 \wedge F0 \wedge 2F \wedge 09 \wedge 00 \wedge 00 \wedge 00 \wedge 00 = 97$ (^ is XOR).

Here recommend a check code online computing website: <http://www.ip33.com/lrc.html>



Note

- There is a separate CHKS for every ten bytes
- If the host sends the server drive an address that does not exist on the network, the server drive will not respond.
- When the host sends a correct data, the slave station will look for the corresponding address of the slave station data and check the parity value, if the parity value does not match, the slave station will not respond.

8.4.2 RS232 data protocol

The data protocol is different from the transmission protocol, and its content refers to the 8 data bytes of the above 10 bytes above. iSMK and FD1X5 series servo drive internal data definition is compliant with Canopen international standards. Numerical and functions are expressed through indexes and sub -indexes.

A: Downloading (From master to slave)

Download means that the master sends a command to write a value to the slave object. If downloaded to a non-existent object, the master will generate an error.

Master station sends data format

Byte 0	Byte 1	Byte 2	Byte 3	Byte 4	Byte 5	Byte 6	Byte 7
Function code	Index		Subindex	Data			

Function code : Specifies the direction and size of the data transfer

23(0x16): Send 4 bytes of data (bytes 4... 7 Contains 32 bits)

2B(0x16): Send 2 bytes of data (bytes 4... 5 Contains 16 bits)

2F(0x16): Send 1 byte of data (bytes 4 contains 8 bits)

Index: The address of the sending object, 16 bits

Subindex: Subaddress of the sending object, 8 bits

Data : The data to be sent (the order of the four bytes in the data is high byte after, low byte before)

For example:

Write 600rpm to the "target speed" of the slave station, the internal unit of 2FF0.09 is rpm, 600 is decimal, and the hexadecimal representation is 258. Since the length of the object to be written is 4 bytes, but the result is only two bytes, it should be filled with 0 at the high level, so the final result =00 00 02 58, the byte order sent is 58 02 00 00

Slave response data format

Byte 0	Byte 1	Byte 2	Byte 3	Byte 4	Byte 5	Byte 6	Byte 7
Function code	Index		Subindex	Reserve			

Function code : Specifies the direction and size of the data transfer

60(0x16): Data sent successfully

80(0x16): Error, by byte 4... 7 generation

Index: The address of the sending object, 16 bits, Same as the main station

Subindex: Subaddress of the sending object, 8 bits, Same as the main station

Reserve: Reserved

B: Upload (From slave to master)

Upload means that the master sends a command to read the address of the slave object. Uploading an address that does not exist will result in an error for the master.

Function code: Define the direction of the data transfer

40(0x16) : Read data

Index: The address of the sending object, 16 bits

Subindex: Subaddress of the sending object, 8 bits

Reserve: Byte 4... 7 no use

Slave receive data

Byte 0	Byte 1	Byte 2	Byte 3	Byte 4	Byte 5	Byte 6	Byte 7
Function code	Index		Subindex	Data			

Function code: Display slave response

43(0x16): Bytes 4... 7 contains 32 bits

4B(0x16): Bytes 4... 5 contains 16 bits

4F(0x16): Bytes 4 contains 8 bits

80(0x16): Error, by byte 4... 7 generation

Index: The address of the sending object, 16 bits, Same as the main station

Subindex: Subaddress of the sending object, 8 bits, Same as the main station

Data: Data returned from the slave station

If there is no error in the data, byte 4... 7 saves the value of the slave object, low byte in front, high byte in back.

If there is an error in the data, the four bytes of data are not equal to the value of the slave object.

For example:

The master sends an "upload" command to the slave:

01 40 F0 2F 09 00 00 00 00 97 (This command is to read the target speed of the slave station 2FF00910)

Slave station response:

01 4B F0 2F 09 58 02 00 00 32

Description:

01: The slave station number is 1

4B: 2 bytes are received, saved by byte4 and byte5 in the 10 bytes of the response

F0 2F: The object index address is 2FF0

09: The address of the object subindex is 09

58 02 00 00: The value is 00 00 02 58(hex)= 600 rpm

Table 8-3 Setting homing mode, position mode, and speed mode through RS232 communication

Homing mode				
Parameter address	Name	Value	Message(ID=1)	Note
60400010	Control word	F	Send→01 2B 40 60 00 0F 00 00 00 25 Receive←01 60 40 60 00 0F 00 00 00 F0	Home turning signal speed and Homing signal velocity are expressed in decimal DEC by default DEC=[(RPM*512*[641003])/1875]
60600008	Operating mode	6	Send→01 2F 60 60 00 06 00 00 00 0A Receive←01 60 60 60 00 06 00 00 00 D9	
60980008	Homing mode	33	Send→01 2F 98 60 00 21 00 00 00 B7 Receive←01 60 98 60 00 21 00 00 00 86	

60990120	Home turning signal speed	200RPM	Send→01 23 99 60 01 03 9D 36 00 0C Receive←01 60 99 60 01 03 9D 36 00 CF	
60990220	Homing signal velocity	100RPM	Send→01 23 99 60 02 82 4E 1B 00 F6 Receive←01 60 99 60 02 82 4E 1B 00 B9	
60400010	Controlword	1F	Send→01 2B 40 60 00 1F 00 00 00 15 Receive←01 60 40 60 00 1F 00 00 00 E0	
Send 01 40 41 60 00 00 00 00 1E read status word, Drive response 01 4B 41 60 00 31 C0 FF FF 24, bit15=1 indicates homing found				
Position mode				
Parameter address	Name	Value	Message(ID=1)	Note
60400010	Control word	2F	Send→01 2B 40 60 00 2F 00 00 00 05 Receive←01 60 40 60 00 2F 00 00 00 D0	The trapezoidal speed is expressed in decimal DEC by default DEC=[(RPM*512*[641003])/1875]
		4F	Send→01 2B 40 60 00 4F 00 00 00 E5 Receive←01 60 40 60 00 4F 00 00 00 B0	
60600008	Operating mode	1	Send→01 2F 60 60 00 01 00 00 00 0F Receive←01 60 60 60 00 01 00 00 00 DE	
607A0020	Target position	50000inc	Send→01 23 7A 60 00 50 C3 00 00 EF Receive←01 60 7A 60 00 50 C3 00 00 B2	
60810020	Trapezoidal speed	200RPM	Send→01 23 81 60 00 03 9D 36 00 25 Receive←01 60 81 60 00 03 9D 36 00 E8	
60830020	Trapezoidal acceleration	100rps/s	Send→01 23 83 60 00 6E A3 01 00 E7 Receive←01 60 83 60 00 6E A3 01 00 AA	
60840020	Trapezoidal deceleration	100rps/s	Send→01 23 84 60 00 6E A3 01 00 E6 Receive←01 60 84 60 00 6E A3 01 00 A9	Trapezoidal acceleration and trapezoidal deceleration are expressed in decimal DEC by default. DEC=[(RPS/S*65536*[641003])/4000000] 2F→3F: absolute location 4F→5F: relative location
60400010	Controlword	3F	Send→01 2B 40 60 00 3F 00 00 00 F5 Receive←01 60 40 60 00 3F 00 00 00 C0	
		5F	Send→01 2B 40 60 00 5F 00 00 00 D5 Receive←01 60 40 60 00 5F 00 00 00 A0	
Send 01 40 41 60 00 00 00 00 1E read the status word, Drive response 01 4B 41 60 00 37 C4 FF FF 1A, bit10 represents Target_reached				
Speed mode				
Parameter address	Name	Value	Message(ID=1)	Note
60600008	Operation mode	3	Send→01 2F 60 60 00 03 00 00 00 0D Receive←01 60 60 60 00 03 00 00 00 DC	The target speed is expressed in decimal DEC by default DEC=[(RPM*512*[641003])/1875] Trapezoidal acceleration and trapezoidal deceleration are expressed in decimal DEC by default: DEC=[(RPS/S*65536*[641003])/4000000]
60FF0020	Target speed	-100RPM	Send→01 23 FF 60 00 7E B1 E4 FF 6B Receive←01 60 FF 60 00 7E B1 E4 FF 2E	
60400010	Control word	2F	Send→01 2B 40 60 00 2F 00 00 00 05 Receive←01 60 40 60 00 2F 00 00 00 D0	
60830020	Trapezoidal acceleration	100rps/s	Send→01 23 83 60 00 6E A3 01 00 E7 Receive←01 60 83 60 00 6E A3 01 00 AA	
60840020	Trapezoidal deceleration	100rps/s	Send→01 23 84 60 00 6E A3 01 00 E6 Receive←01 60 84 60 00 6E A3 01 00 A9	
Note: The message is expressed in hexadecimal, and the motor resolution used in this case is 65536				

8.5 Troubleshooting Measures for Communication Faults

When the driver cannot communicate with the host computer, please check the driver communication parameters and wiring; When the drive is prone to disconnection, read-only no write or only write no read and other problems, you can check through the following aspects:

Serial number	Check item	Description
1	Terminal resistance	When the 485 communication rate is high and the communication distance is long, the signal will be reflected at the end of the transmission line, so it is necessary to parallel a 120Ω terminal resistor at the beginning and end of the communication network. Since the FD servo drive has its own terminal resistance, it is only necessary to dial the dip switch of the first and last drive to the ON position.
2	Cable specification	The recommended wire diameter of 485 signal cable is 24AWG, and the shielded twisted pair cable should be used, and the shielding layer of the cable should be grounded together and the grounding resistance should not be greater than 1Ω. The use of twisted pair cables can effectively eliminate adversarial interference, and the cable with a good shielding layer can effectively reduce the impact of external interference sources.
3	Reasonable wiring	The distance between communication cables and strong-current cables should be at least 20cm. If the cables can be folded into metal pipes, the anti-interference capability is better. During the wiring process, the signal line and the power line intersect vertically, and parallel laying should be avoided as far as possible.
4	Good grounding	The motor power line must be a cable with a shielded network, the motor PE must be connected to the driver ground terminal, and the driver shell must be well grounded.
5	Power interference	Power interference. The instability of the power supply of the grid will also directly affect the normal use of the servo, and the external circuit of the driver can be connected by referring to Chapter 3.

Chapter 9 CANopen Communication

9.1 CANopen communication protocol introduction

CANopen is the most famous and successful of the open fieldbus standards, which has been widely recognized and widely used in Europe and the United States. In 1992, the Association of Automation CAN Users and Manufacturers (CiA) was established in Germany and began to develop CANopen, an application layer protocol for automation CAN. Since then, the members of the Association have developed a series of CANopen products, which are widely used in machinery manufacturing, pharmaceuticals, food processing and other fields.

FD1X5 and iSMK servos are standard CAN slave devices that strictly follow the CANopen 2.0A/B protocol and can communicate with any host computer that supports the protocol. The FD1X5 and iSMK servos use a strictly defined list of objects, which we call the Object Dictionary. This object dictionary is designed based on the CANopen international standard, and all objects have clear functional definitions. The Objects mentioned here are similar to the memory address we often say, some objects such as speed and position can be modified by the external controller, and some objects can only be modified by the drive itself, such as status and error messages. These objects are hexadecimal numbers. For example, the CANopen address in working mode is 0x60400010, as shown in Table 9-1.

Table 9-1 The example object dictionaries lists

Complete CANopen address composition			property	Meaning
Index	Subindex	Bits(Data length)		
0x6040	00	0x10	RW	Device status control word
0x6060	00	0x08	RW	operate mode
0x607A	00	0x20	W	Target position
0x6041	00	0x10	MW	Device status word

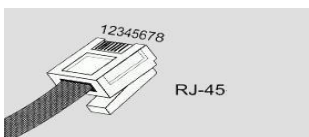
The properties of an object are as follows:

1. RW(Read and write) : Objects can be read or written;
2. RO(read-only) : The object can only be read;
3. WO (Write only) : Write only;
4. M (Mappable) : Objects can be mapped, similar to indirect addressing;
5. S (Storable) : Objects can be stored in the Flash-ROM area and are not lost when powered off.

9.2 Hardware Description

FD1X5 series servo driver CANopen port hardware definition is as follows:

Table 9-2 Pin name and function description table

	Pin	Signal identification	Signal name
	1	CAN_H	CAN_H bus (high dominant)
	2	CAN_L	CAN_L bus (low dominant)
	3	CAN_GNDB	Signal ground

iSMK series servo driver CANopen port hardware definition is as follows:

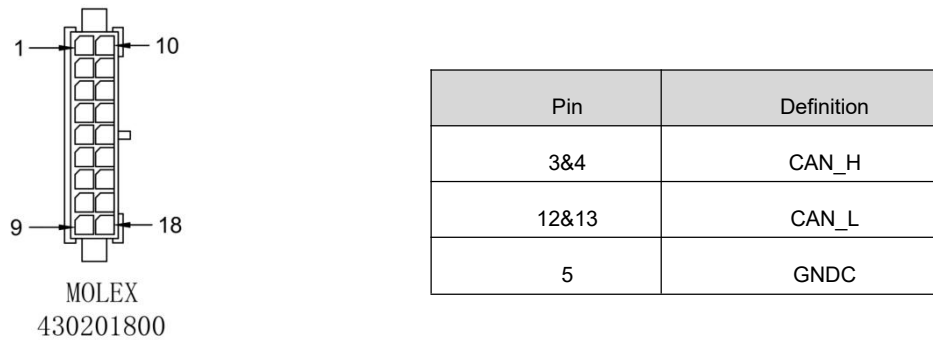


Figure 9-1 iSMK drive canopen definition

CAN communication protocol mainly describes the mode of information transmission between devices. The definition of CAN layer is consistent with the open system interconnection model (OSI). Each layer communicates with the same layer on another device. The actual communication occurs in the two adjacent layers of each device, and the devices are only interconnected through the physical medium of the physical layer of the model. The specification of CAN defines the bottom two layers of the model, the data link layer and the physical layer. CAN bus physical layer is not strictly stipulated, can use a variety of physical media such as twisted pair optical fiber, etc., the most commonly used is twisted pair signal, the use of differential voltage transmission (commonly used bus transceiver), two signal lines are called CAN_H and CAN_L, static time is about 2.5V, at this time the state is expressed as logic 1, can also be called hidden bit, CAN_H is higher than CAN_L to represent logical 0, which is called display, and the usual voltage value at this time is CAN_H=3.5V and CAN_L=1.5V, and display is preferred in competition. Table 9-2 and Figure 9-1 show the names and functions of CAN communication port pins.

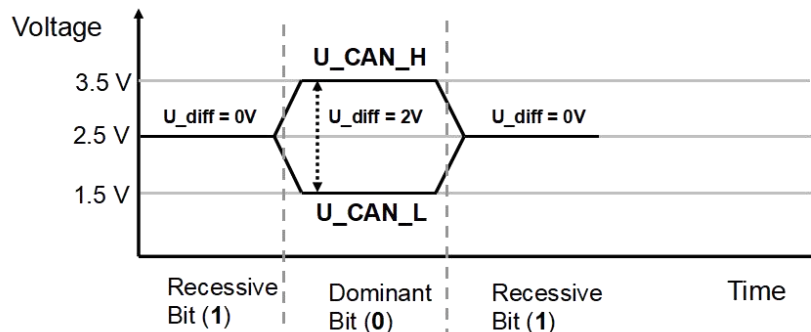


Figure 9-2 CAN Signal Identification

Note:

- 1.All CAN_L and CAN_H pins of the slave station can be directly connected and connected by series connection.
- 2.Connect the master terminal and the last slave terminal to a terminal resistor of 120 Ω . The FD1X5 drive comes with a terminal resistance dip switch SW4, which is set to ON to enable the terminal resistance. Restart the drive after changing the terminal resistance dip status; iSMK do not contain internal terminal resistors, so it need to be connected externally.
- 3.Use shielded twisted pair cables for communication cables and ground them properly. (The 3-pin ground cable can be disconnected for short-distance communication, but it is recommended to ground the 3-pin for long-distance, high-baud communication.)
- 4.Table 9-3 lists the theoretical maximum communication distances of different baud rates.
- 5.The FD1X5 and iSMK series servo drives do not require an external 24V power supply to power the CAN.

Table 9-3 The longest distance table that can theoretically communicate with each baud rate

Communication speed (bit/s)	Communication distance (M)
1M	25
800K	50
500K	100
250K	250
125K	500
50K	600
25K	800
10K	1000

9.3 Software Description

9.3.1 EDS description

EDS (electronic data form) file is the identification file or similar code of the slave station connected to the PLC, through which to identify the type of slave station (which is similar in 401, 402, 403, or which device belongs to 402). This file contains all the information of the slave station, such as manufacturer, serial number, software version, supported baud rate type, OD that can be mapped and the attributes of each OD and so on, similar to the GSD file of Profibus. Therefore, before hardware configuration, we first need to import the EDS file from the station to the upper configuration software.

9.3.2 SDO Description

SDO is mainly used to transmit low-priority objects between devices. Typically, it is used to configure and manage slave devices, such as modifying PID parameters and PDO configuration parameters of current ring, speed ring, position ring, etc. This kind of data transmission is the same as MODBUS, that is, after the master station sends out, the slave station needs to return data response. This communication mode is only suitable for parameter setting, and is not suitable for data transmission with high real-time requirements.

The communication mode of SDO is divided into upload and download, and the host computer can read and write the OD inside the servo according to the special SDO read and write instructions. In the CANopen protocol, the content of the Object dictionary can be modified through the Service Data Object (SDO). The following describes the structure of the SDO command and the guidelines to follow.

The basic structure of SDO is as follows: Client→Server/Server→Client

Byte0	Byte1-2	Byte3	Byte4-7
SDO Command specifier	Object Index	Object subindex	Maximum 4 bytes of data

SDO command word contains the following information:

- Download/upload
- Request/response
- Segmented/expedited transfer
- CAN the frame data byte length, which is used to alternately clear and set the toggle bit for each subsequent segment

There are five request/reply protocols implemented in SDO:

- Initiate domain Download
- Download Domain Segment
- Initiate Domain Upload;
- Upload Domain Segment
- Abort Domain Transfer

Among them, Download refers to write operation of the object dictionary, Upload refers to read operation of the object dictionary; Use the Initiate Domain Upload protocol when reading parameters; When setting parameters, use the Initiate Domain Download protocol; The syntax of the protocol's SDO command word (the first byte of an SDO CAN message) is described in Table 8-4 and Table 8-5, where "-" indicates that it is irrelevant and should be 0.

Table 9-4 Start domain download

Bit	7	6	5	4	3	2	1	0
Client→	0	0	1	-	n		e	s
←Server	0	0	1	-	-	-	-	-

Table 9-5 Start domain upload

Bit	7	6	5	4	3	2	1	0
Client→	0	0	1	-	-	-	-	-
←Server	0	0	1	-	n		e	s

Description:

n——Indicates the number of bytes of meaningless data in the packet data [from (8-n) bytes to the seventh byte of meaningless data] (n is valid when e=1 and s=1, otherwise n is 0);

e——Normal transmission when e=0, accelerated transmission when e=1;

s——Indicates whether the data length is specified. 0 indicates that the data length is not specified, and 1 indicates that the data length is specified.

e=0, s=0——Retained by the CiA;

e=0, s=1——The data byte is the byte counter, byte4 is the low data part (LSB), byte7 is the high data part (MSB);

e=1——ata bytes are the data to be downloaded.

SDO message format description

The transmission of SDO is an object data transmission of no more than 4 bytes, and the message consists of a COB-ID and a data segment. The following table shows that the COB-ids of the sending SDO(RSD) and the receiving SDO do not agree.

Data segments are arranged in the "low position in front, high position in back" mode. All SDO message data segments must be eight bytes. The format of the SDO transmission message is shown in the following table.

Table 9-6 SDO transmit message format table

	COB-ID	DLC	Data							
			0	1	2	3	4	5	6	7
Master →	0x600+Node_ID	8	Send command word	Object Index	Object subindex	00				
← Slave	0x580+Node_ID	8	Receive command word	Object Index	Object subindex	Maximum 4 bytes of data				

The command code specifies the transmission type and data length of the SDO, the index and subindex are the objects to be transmitted, and the data is the numerical value of the object.

SDO read message

Depending on the length of the received data, the received SDO command word changes, and the message format is as follows:

Table 9-7 SDO reads message description

	COB-ID	DLC	Data							
			0	1	2	3	4	5	6	7
→ Master	0x600+Node_ID	8	40	Object index		Object subindex	-	-	-	-
← Slave	Normal	0x580+Node_ID	8	4F	Object index	Object subindex	Data	-	-	-
	Normal	0x580+Node_ID	8	4B	Object index	Object subindex	Data		-	-
	Normal	0x580+Node_ID	8	43	Object index	Object subindex	Data			
	Error	0x580+Node_ID	8	80	Object index	Object subindex	Error code			

The command word sent by the SDO message is 0x40 when the parameter is read. The command word received will be different depending on the length of the message data returned by the driver.



Note

"-" indicates that data exists but is not considered. You are advised to write 0 when writing data.

SDO write message

Using SDO to modify parameters for objects no larger than 4 bytes, the transmission message varies according to the read and write mode and the inconsistency of the content data length. SDO write messages as shown in the following table:

Table 9-8 SDO write message description

	COB-ID	DLC	Data							
			0	1	2	3	4	5	6	7
→ Master	0x600+Node_ID	8	2F	Object index		Object subindex	Data	-	-	-
	0x600+Node_ID	8	2B	Object index		Object subindex	Data		-	-
	0x600+Node_ID	8	23	Object index		Object subindex	Data			
← Slave	Normal	0x580+Node_ID	8	60	Object index	Object subindex	-	-	-	-
	Error	0x580+Node_ID	8	80	Object index	Object subindex	Error code			

When writing parameters, the command word is related to the data length of the object when the SDO message is sent. If the data to be sent is 1 byte, the command word is 0x2F. If the data to be sent is 2 bytes, the command word is 0x2B. If the data to be sent is 4 bytes, the command word is 0x23. The SDO message is successfully sent, and the received command word is 0x60. The SDO message failed to be sent with the received command word 0x80.

Example:

The slave station number is 1, the SDO is used to write the object to the target position 607A.00, and the write value is 100000, that is, 0x186A0. The master station sends a message as shown in the following table. (All in hexadecimal)

Master send SDO message

COB-ID	DLC	Data							
		0	1	2	3	4	5	6	7
0x601	8	23	7A	60	00	A0	86	01	00

Write normal drive receives SDO message

COB-ID	DLC	Data							
		0	1	2	3	4	5	6	7
0x601	8	60	7A	60	00	A0	86	01	00

If the write is abnormal, the error command word 0x80 is returned

COB-ID	DLC	Data							
		0	1	2	3	4	5	6	7
0x601	8	80	7A	60	00	01	00	01	06

Table 9-9 SDO message error code

Error code	Code function description
0x05040001	Invalid command, unknown or illegal Client/Server command word
0x06010001	Attempts to read only write object parameters
0x06010002	An attempt was made to write read-only object parameters
0x06020000	Invalid index. The object does not exist in the object dictionary
0x06040041	Cannot be mapped, object parameters do not support mapping to PDO
0x06060000	The drive is in an error state, causing the object parameter access failure
0x06070010	The data type and length of the service parameter do not match
0x06070012	The data type does not match, and the length of the service parameter is too large
0x06070013	The data type does not match, and the length of the service parameter is too short
0x06090011	Invalid subindex
0x06090030	Invalid data, out of range of object parameters
0x06090031	The value of the written data is too large
0x06090032	Write data value is too small
0x08000022	Data cannot be transferred or saved to the application due to the current device state

Table 9-10 Set the origin mode via SDO messages

Parameter address	Name	Value	message(ID=1)
60400010	Control word	F	Send→601 2B 40 60 00 0F 00 00 00 Receive←581 60 40 60 00 0F 00 00 00
60600008	Operate mode	6	Send→601 2F 60 60 00 06 00 00 00 Receive←581 60 60 60 00 06 00 00 00
60980008	Homing mode	33	Send→601 2F 98 60 00 21 00 00 00 Receive←581 60 98 60 00 21 00 00 00
60990120	Homing transition signal speed	200RPM	Send→601 23 99 60 01 03 9D 36 00 Receive←581 60 99 60 01 03 9D 36 00
60990220	Homing signal speed	100RPM	Send→601 23 99 60 02 82 4E 1B 00 Receive←581 60 99 60 02 82 4E 1B 00
60400010	Control word	1F	Send→601 2B 40 60 00 1F 00 00 00 Receive←581 60 40 60 00 1F 00 00 00
Send 601 40 41 60 00 00 00 00 00 Read the status word and the drive replies 581 4B 41 60 00 31 C0 FF FF, bit15=1 for origin found			

Table 9-11 Setting the position mode via SDO message

Parameter address	Name	Value	message(ID=1)
60400010	Control word	2F	Send→601 2B 40 60 00 2F 00 00 00 Receive←581 60 40 60 00 2F 00 00 00
		4F	Send→601 2B 40 60 00 4F 00 00 00 Receive←581 60 40 60 00 4F 00 00 00
60600008	Operate mode	1	Send→601 2F 60 60 00 01 00 00 00 Receive←581 60 60 60 00 01 00 00 00
607A0020	Target position	50000inc	Send→601 23 7A 60 00 50 C3 00 00 Receive←581 60 7A 60 00 50 C3 00 00
60810020	Trapezoidal speed	200RPM	Send→601 23 81 60 00 03 9D 36 00 Receive←581 60 81 60 00 03 9D 36 00

60830020	Trapezoidal acceleration	100rps/s	Send→601 23 83 60 00 6E A3 01 00 Receive←581 60 83 60 00 6E A3 01 00
60840020	Trapezoidal deceleration	100rps/s	Send→601 23 84 60 00 6E A3 01 00 Receive←581 60 84 60 00 6E A3 01 00
60400010	Control word	3F	Send→601 2B 40 60 00 3F 00 00 00 Receive←581 60 40 60 00 3F 00 00 00
		5F	Send→601 2B 40 60 00 5F 00 00 00 Receive←581 60 40 60 00 5F 00 00 00
Send 601 40 41 60 00 00 00 00 00 Read the status word and the drive replies 581 4B 41 60 00 37 C4 FF FF,bit10 representing the target location reach			

Table 9-12 Speed mode is set through SDO message

Parameter address	Name	Value	message(ID=1)
60600008	Operate mode	3	Send→601 2F 60 60 00 03 00 00 00 Receive←581 60 60 60 00 03 00 00 00
60FF0020	Target position	-100RPM	Send→601 23 FF 60 00 7E B1 E4 FF Receive←581 60 FF 60 00 7E B1 E4 FF
60400010	Control word	2F	Send→601 2B 40 60 00 2F 00 00 00 Receive←581 60 40 60 00 2F 00 00 00
60830020	Trapezoidal acceleration	100rps/s	Send→601 23 83 60 00 6E A3 01 00 Receive←581 60 83 60 00 6E A3 01 00
60840020	Trapezoidal deceleration	100rps/s	Send→601 23 84 60 00 6E A3 01 00 Receive←581 60 84 60 00 6E A3 01 00

Note: The message is expressed in hexadecimal, and the motor resolution used in this case is 65536

9.3.3 PDO Description

PDO can transmit 8 bytes of data at a time, with no other protocol presetting (meaning that the data content is predefined), and is mainly used to transmit data requiring high frequency exchange.

The transmission mode of PDO breaks the existing data question-and-answer transmission concept and adopts a new data exchange mode. The two sides of the device define the data receiving and sending area in each device before transmission, and directly send the relevant data to the data receiving area of the other side during data exchange, which reduces the question-and-answer inquiry time and greatly improves the efficiency of bus communication. As a result, high bus utilization is achieved.

9.3.3.1 PDO COB-ID Description

COB-ID is a unique method of CANopen Communication protocol. Its full name is Communication Object Identifier-Communication object-ID. These COB-ids define the corresponding transport levels for PDO. The controller and the servo can define the same transmission level and the transmission content in their respective software configurations, so that after the controller and the servo use the same transmission level and transmission content, the data transmission is transparent, that is, both sides know the data content to be transmitted. It is not necessary to reply whether the data is transmitted successfully when the data is transmitted.

The default ID allocation table is based on the 11-bit CAN-ID defined by CANopen 2.0A (CANopen 2.0B protocol COB-ID is 29 bits), which contains a 4-bit function code part and a 7-bit Node-ID part, as shown in Figure 9-3.

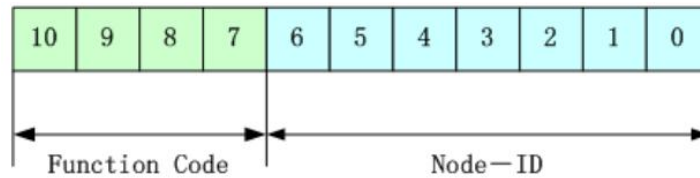


Figure 9-3 Default ID description diagram

Note

Node-ID — The station number of the servo. The Node-ID ranges from 1 to 127.

Function Code — Function codes for data transmission, which define the transmission levels of various PDO, SDO, and management packets. The smaller the function codes, the higher the priority.

Table 9-13 CANopen predefined master/slave connection set CAN identifier assignment table

Object	COB-ID
NMT Module Control	000H
SYNC	080H
TIME SSTAMP	100H
Object	COB-ID
Emergency	081H-0FFH
PDO1 (Send)	181H-1FFH
PDO1 (Receive)	201H-27FH
PDO2 (Send)	281H-2FFH
PDO2 (Receive)	301H-37FH
PDO3 (Send)	381H-3FFH
PDO3 (Receive)	401H-47FH
PDO4 (Send)	481H-4FFH
PDO4 (Receive)	501H-57FH
SDO (Send/server)	581H-5FFH
SDO (Receive/customer)	601H-67FH
NMT Error Control	701H-77FH

Note

- The smaller the COB-ID, the higher the priority.
- The function code before the COB-ID of each level is in a fixed format.
- The COB-ID 00H, 80H, 100H, 701H-77FH, and 081H-0FFH are all system management formats.

9.3.3.2 COB-ID

- Send PDO relative to the servo refers to the data sent by the servo, which is received by the PLC. The function code (COB-ID) for sending the PDO is:
 - 1.0x180+ Servo station NO.
 - 2.0x280+ Servo station NO.
 - 3.0x380+ Servo station NO.
 - 4.0x480+ Servo station NO.
- Receiving PDO relative to the servo refers to the data received by the servo, which is sent by the PLC, and the function code (COB-ID) for sending PDO is:
 - 1.0x200+ Servo station NO.
 - 2.0x300+ Servo station NO.
 - 3.0x400+ Servo station NO.
 - 4.0x500+ Servo station NO.



Note

Since the FD1X5 and iSMK series servo drives are designed according to the standard CANopen 2.0A protocol, but also support CANopen 2.0B protocol, which means that if the above eight Pdos are not enough, you can also define a new PDO. For example, 0x43FH is used as the communication PDO of station 1, as long as the controller and the servo are defined in accordance with this.

9.3.3.3 PDO transmission type

- SYNC - Transmission triggered by a synchronization message (transmission type: 0-240)

In this transmission mode, the controller must have the ability to send synchronous messages (periodic messages with a frequency of up to 1KHZ), which the servo sends after receiving the synchronous message.

Aperiodic - pre-triggered transfer by a remote frame, or by an object-specific event specified in the device subprotocol. In this mode, the data in the PDO is sent once every time the servo drive receives a synchronization message.

Periodic - Delivery is triggered after every 1 to 240 SYNC messages. In this mode, the data in the PDO is sent once every time the servo drive receives n synchronization packets.

When CANopen communication is configured in synchronous transmission mode, the driver uploads the mapped data in TPDO only after receiving the synchronization message.

TPDO1	TPDO2	TPDO3	TPDO4	TPDO5	TPDO6	TPDO7	TPDO8
Index	Name	Value	Unit				
1	1A0000	Group_TX1_PDO	2	DEC			
2	1A0001	TX1_PDO1	60630020	HEX			
3	1A0002	TX1_PDO2	60410010	HEX			
4	1A0003	TX1_PDO3		HEX			
5	1A0004	TX1_PDO4		HEX			
6	1A0005	TX1_PDO5		HEX			
7	1A0006	TX1_PDO6		HEX			
8	1A0007	TX1_PDO7		HEX			
9	1A0008	TX1_PDO8		HEX			
10	180001	TX1_ID	00000181	HEX			
11	180002	TX1_Transmission		1	DEC		
12	180003	TX1_Inhibit_Time		0	DEC		
13	180005	TX1_Event timer			DEC		

Figure 9 - 4 TPDO configuration in synchronous mode

Table 9 - 14 TPDO configuration in synchronous mode

Name	Meaning
TPDO1 Mapping group	2, the number of objects configured in this PDO, TPDO1 is configured with two objects: actual location and status word
Mapping 1-8	Configure the servo-CANOPEN control object
TPDO1 station number	180+ Drive ID (TPDO2 station number should be set to: 280+ drive ID)
TPDO1 Transport type	Synchronous transmission mode: The driver sends TPDO to the controller after receiving synchronization packets
TPDO1 Disable time	It must be set to 0

Note: The sum of the actual position and status word length of the assigned object in TPDO1 is 4+2=6 bytes



Note

- The sum of the actual position of the object and the length of the status word in TPDO1 is 4+2=6 bytes. The default RPDO transmission mode is 254. You do not need to set the transmission mode. The transmission mode takes effect immediately after data is received.
- The default value of synchronizing packets is

COB-ID	DLC
0x80	0

- Asynchronous (Transfer type: 254/255)

The slave station sends the packet after the change regardless of whether the master station asks for it. In addition, you can define the interval between sending the same packet twice to prevent the packets with higher priorities from occupying the bus all the time (the lower the value of PDO, the higher the priority).

For FD1X5 and iSMK series servo drives, it supports all 256 transmission modes, and the user only needs to select the transmission mode of the drive according to the transmission mode supported by the controller.

In asynchronous transfer mode, the mapped object data in PDO is transmitted as soon as it changes.

TPDO1	TPDO2	TPDO3	TPDO4	TPDO5	TPDO6	TPDO7	TPDO8
Index	Name		Value	Unit			
1	1A0000	Group_TX1_PDO		2	DEC		
2	1A0001	TX1_PDO1	60630020	HEX			
3	1A0002	TX1_PDO2	60410010	HEX			
4	1A0003	TX1_PDO3		HEX			
5	1A0004	TX1_PDO4		HEX			
6	1A0005	TX1_PDO5		HEX			
7	1A0006	TX1_PDO6		HEX			
8	1A0007	TX1_PDO7		HEX			
9	1A0008	TX1_PDO8		HEX			
10	180001	TX1_ID	00000181	HEX			
11	180002	TX1_Transmission	254	DEC			
12	180003	TX1_Inhibit_Time	10	DEC			
13	180005	TX1_Event timer	0	DEC			

Figure 9-5 TPDO configuration in asynchronous transport mode

Table 9-15 TPDO configuration in asynchronous transport mode

Name	Meaning
TPDO1 Mapping group	Indicates the number of objects configured in the PDO. TPDO1 is configured with two objects: actual location and status word
Mapping 1-8	Configure the servo-CANOPEN control object
TPDO1 station number	180+ Drive ID (TPDO2 station number should be set to: 280+ drive ID)
TPDO1 Transport type	254 or 255, asynchronous transmission mode
TPDO1 Disable time	The unit is ms. This parameter prevents the network from being blocked by frequent packets sent by the server. In multi-axis asynchronous transmission mode, set this parameter based on site requirements



Note

- The sum of the actual position of the object and the length of the status word in TPDO1 is 4+2=6 bytes.
- The default RPDO transfer mode is 254. This parameter takes effect immediately after data is received.
- A PDO can specify a forbidden time, that is, define the minimum interval between two consecutive PDO transmissions, to avoid the problem that the data of high priority information always occupies the bus because the amount of data is too large, and other low priority data cannot compete with the bus. The forbidden time is defined by a 16-bit unsigned integer, in 1ms.

- Event time reporting function

In asynchronous transfer mode, in addition to the instantaneous, the event time can be set if the driver needs to periodically upload data to the controller.

TPDO1	TPDO2	TPDO3	TPDO4	TPDO5	TPDO6	TPDO7	TPDO8
Index	Name		Value	Unit			
1	1A0000	Group_TX1_PDO	2	DEC			
2	1A0001	TX1_PDO1	60630020	HEX			
3	1A0002	TX1_PDO2	60410010	HEX			
4	1A0003	TX1_PDO3		HEX			
5	1A0004	TX1_PDO4		HEX			
6	1A0005	TX1_PDO5		HEX			
7	1A0006	TX1_PDO6		HEX			
8	1A0007	TX1_PDO7		HEX			
9	1A0008	TX1_PDO8		HEX			
10	180001	TX1_ID	00000181	HEX			
11	180002	TX1_Transmission	254	DEC			
12	180003	TX1_Inhibit_Time	0	DEC			
13	180005	TX1_Event timer	50	DEC			

Figure 9 - 6 Event time is used to schedule the upload in asynchronous mode

Table 9 - 16 Event time is used to schedule the upload in asynchronous mode

Name	Meaning
TPDO1 Mapping group	Represents the number of objects configured in the PDO. TPDO1 is configured with two objects: actual location and status word
Mapping 1-8	Configure the servo-CANOPEN control object
TPDO1 station number	180+ Drive ID (TPDO2 station number should be set to: 280+ drive ID)
TPDO1 Transport type	254 or 255, asynchronous transmission mode
TPDO1 Disable time	When uploading using event time, this object is set to 0
TPDO1 Event time	Cycle time (in ms) for the driver to send PDO to the controller
Note: The sum of the actual position and status word length of the assigned object in TPDO1 is 4+2=6 bytes	

9.3.3.4 Protection Mode/Monitoring Type Description

Monitoring type refers to the check method selected by the master station to check the slave station during operation. Through these two ways, the slave station can be judged whether there is a fault, and the corresponding treatment is made according to these faults!

1. Master heartbeat message

The slave station periodically uploads the message to the master station at the "monitoring time". If the master station does not receive the next heartbeat message from the slave station after the "heartbeat consumer time", the master station determines that the communication is wrong and the master station generates an alarm!

Table 9-17 The format of the heartbeat packet was uploaded from the slave station

COB-ID	Byte 0
0x700+Node_ID	State
Case message (slave ID=1) : 701 05	

2. Slave heartbeat message

The master station periodically sends packets to the slave station according to the "monitor time". If the slave station does not receive the next heartbeat packet from the master station after the "Heartbeat Producer time", the slave station determines that the communication is wrong! When the communication interrupt mode (0x600700 set) is 1, the driver will alarm and stop when the CAN communication fails.

Table 9-18 The format of heartbeat packets sent by the master station

COB-ID	Byte 0
0x700+master ID	Master station status
Case message (primary ID=127) : 77F 05	

Table 9-19 Status value meaning

State value	Meaning
0x00	boot-up
0x04	Stopped
0x05	Operational
0x7f	Pre-operational

When a Heartbeat node starts, its Boot-up packet is the first Heartbeat packet.



Note

The generation time of heartbeat message and the heartbeat packets of the slave station are configured by the master station when the power is turned on, and they are not saved by default when the power is off.

3. Node protection

The master station periodically sends the remote request packet to the slave station in the monitoring time. The slave station responds immediately after receiving the request packet. If the master station does not receive the response packet from the slave station after the Monitoring time x Life Factor time expires, the master station determines that the slave station is wrong. At the same time, the slave station can also monitor the remote request status of the master station and start communication protection from the first remote frame received. If the remote frame of the master station is not received beyond the time of "Node protection time * node protection factor", the slave station will also judge the communication error. The communication interrupt mode (0x600700) needs to be set to 1, and the drive will alarm and stop when CAN communication fails.

Master request message format—— (0x700+node number) (The message has no data)

Slave response message format—— (0x700+node number) +state

Table 9-20 Slave station reply message

COB-ID	Byte 0
0x700+Node_ID	Bit7: trigger bit Bit6-Bit0: status

Table 9-21 Slave station reply packet status value meaning

State value	Meaning
0	Initializing
1	Disconnected
2	Connecting
3	Preparing
4	Stopped
5	Operational
127	Pre-operational

Status ——— The data section includes a trigger bit (bit7), which must be alternately set to "0" or "1" in each node protection response. The trigger bit is set to 0 for the first node protection request. Bits 0 and 6 (bit0 to 6) indicate the node status. Table 9-21 describes the values.

The standard CAN slave station generally supports only one node protection mode, FD1X5 and iSMK series servo drives both support protection mode. However, a node cannot support both node protection and heartbeat message at the same time. Only one of them can be used for protection.

9.3.3.5 Startup process description

CANopen supports both extended boot-up and minimal boot-up procedures during network initialization. The initialization process can be represented by a node state transition diagram, as shown in Figure 9-7.

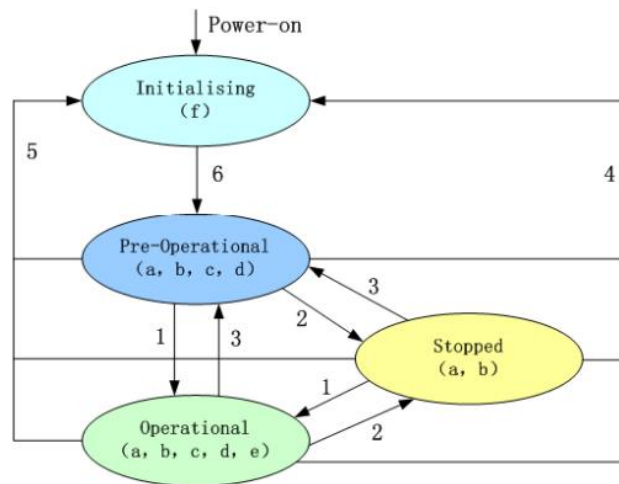


Figure 9-7 Node state transition diagram

Note: The letters in parentheses in the figure indicate communication objects that can be used in different states.

- Including : a——NMT d——Emergency b——Node Guard
- e——PDO c——SDO f——Boot-up

Switching between modes can be achieved through NMT management messages, only the NMT-Master node can send NMT Module Control messages, all slave devices must support the NMT Module Control service, and NMT Module control messages do not need to be answered. After the initialization is complete, the device automatically enters the Pre_Operational state and sends Boot-up messages. NMT message format is as follows: Nmt-master →NMT Slave(s)

Table 9-22 NMT manages the packet format

COB-ID	Byte0	Byte1
0x000	CS	Node-ID

Node-ID=0 indicates that all NMT slave devices are addressed. CS is the command word. Table 9-23 lists the values of CS.

Table 9-23 CS value table

Command word	NMT service
0x01	Enable remote node
0x02	Close remote node
0x80	Enter the pre-operation state
0x81	Reset node
0x82	Reset communication

9.3.3.6 Emergency message description

When a fatal error occurs inside the device, the application device sends an emergency packet with the highest priority to other devices. An emergency message consists of eight bytes.

Table 9-24 Emergency message format

COB-ID	Byte 0-1	Byte2	Byte4-5	Byte6-7
Emergency message station number 0x101400	Emergency error code 0x603F00	Error register 0x100100	error state 0x260100	error state 0x260200

Table 9-25 Emergency error code 0x603F00

Alarm content	Emergency Error Code (Hex)	Alarm content	Emergency Error Code (Hex)
Communication encoder is not connected	0x7331	Current sensor fault	0x5210
Communication encoder multi-turn error	0x7320	Software watchdog reset	0x6010
Communication encoder check error	0x7330	Abnormal interrupt	0x6011
Driver temperature is too high	0x4210	MCU fault	0x7400
The driver bus voltage is too high	0x3210	Motor model configure error	0x6320
The driver bus voltage is too low	0x3220	Motor power line out of phase	0x6321
Driver power part short circuit or motor short circuit	0x2320	Pre-enable alarm	0x5443
Current sampling saturation	0x2321	Positive limit error	0x5442
Driver brake resistance is abnormal	0x7110	Negative limit error	0x5441
Actual following error exceeds allowable	0x8611	SPI fault	0x6012
Logic low voltage	0x5112	Bus communication error	0x8100
Motor or drive is overloaded	0x2350	Bus communication timeout	0x81FF
Input pulse frequency is too high	0x8A80	Full closed loop check error	0x8A81
Excessive motor temperature	0x4310	Main encoder ABZ error	0x7382
Communication encoder is not response	0x7331	Main encoder count error	0x7306
EEPROM data error	0x6310		

Table 9-26 Error register

Bit	Error type
0	Common fault
1	Current
2	Voltage
3	Temperature
4	Communication error
5	Device profile specific
6	Encoder
7	Reserve

9.4 CANopen Bus Communication Setting

This chapter will introduce the setting of CAN bus communication parameters. In the upper computer software interface, click **Specialist** ->**ECAN Configuration** -> **ECAN Settings** to enter the parameter setting interface. When the master station with the network management function is powered on, the parameters of the slave station are initialized by sending SDO. Generally, parameters such as synchronization ID, node protection time, node protection time coefficient, node protection station number, emergency message station number, and heartbeat message generation time do not need to be set by the user.

Table 9 - 27 CANopen relate parameter

CANopen address	Name	Meaning	Default
10050020	Synchronization ID	The transmission type ranges from 1 to 240. This parameter is available in synchronous mode but does not need to be set in asynchronous mode.	80
100C0010	Node protection time	Through node protection, the master station can monitor the current status of each node. The master station sends a remote frame (the default COBID is 0x700+ station number and contains no message) to query the status of the slave node according to the node protection period. The slave node needs to respond within a certain time range, otherwise the master node considers the slave node offline and the driver enters the alarm state.	1000
100D0008	Node protection time coefficient		3
100E0020	Node protection ID	700+ drive ID	
10140020	Emergency message station number	80+ drive station number	
10170010	Timestamp of heartbeat message generation	The slave node periodically sends message to the master node. If the master node does not receive the message within a certain period of time, the slave node is considered to be disconnected	
2F810008	CAN baud rate	CAN baud rate Setting 100: 1M 50: 500k 25: 250k 12: 125k 5: 50k 1: 10k	50
30110108	ECAN synchronization period	In interpolation mode, this parameter is set based on the synchronization packet interval of the master station. In asynchronous mode, this parameter is not required. 0:1ms 1:2ms 2:4ms 3:8ms	2
30110208	ECAN Synchronous clock mode	Set to 1 in interpolation mode to enable the synchronization clock, and set 0 to turn off the synchronization clock in non-interpolation mode	0
30110410	ECAN synchronization Lost count	In synchronization mode, the communication status is monitored. If the value does not change, the communication status is good. If the value keeps changing, interference occurs or the synchronization period is incorrectly set.	
60070010	Communication interrupt mode	CAN communication interruption mode: determines the action logic that the driver still does not receive the node protection packet after the node protection time x node protection coefficient is exceeded 0: No processing 1: An error is reported	0

- Use the PLC to initialize PDO parameter

For the CANopen master station that can import EDS files, PDO Settings in the server are not required, and PDO information can be directly configured in the master station. After power-on, PLC initialization will send SDO messages to configure the PDO of the server. After the configuration is completed, the master station will send startup messages to start the slave station, and then PDO communication can be carried out. Most PLCs can be used in this way, such as: Schneider PLC, Siemens S7-1200+CM CANOPEN module, Buke F1 and so on.



Note

EDS file download address: http://download.kinco.cn/D_Software/Servo/EDS.zip

9.5 Interpolation mode based on CANopen

The interpolation mode is suitable for single-axis operation control and multi-axis synchronous control. The master station performs the motion contour planning, and the target position is periodically updated in the synchronous mode. In the host computer software interface, click **Specialist ->ECAN Configuration -> ECAN Settings** to enter the interpolation mode parameter setting interface.

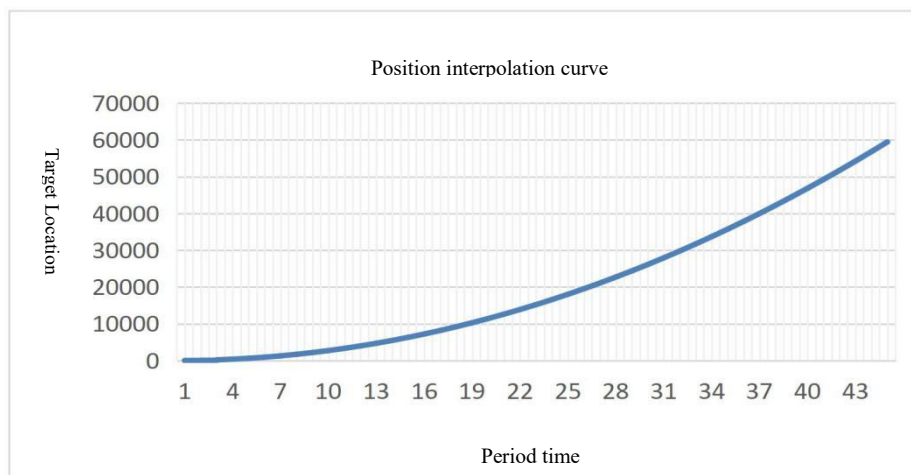


Figure 9-8 Position interpolation curve

Table 9-28 Interpolation control relate parameter

Internal address	Parameter name	Description	Default value
60600008	Operation mode	Set the operation mode to interpolation mode	7
60400010	Controlword	0x1F Enable drive, run interpolation mode 0x06 Loose axis, close drive enable 0x86 Reset drive failure	1F 6 86
607A0020	Target position	target absolute/relative position	User Defined

Internal address	Parameter name	Description	Default value
30110108	ECAN sync period	In interpolation mode, it is set according to the synchronization message cycle of the master station value synchronization period 0 1ms 1 2ms 2 4ms 3 8ms	User Defined
30110208	ECAN Synchronous Clock Mode	Set to 1 in interpolation mode to enable clock synchronization, and set to 0 in non-interpolation mode to disable clock synchronization.	0
30110410	ECAN Sync Loss Count	Monitor the synchronous communication status in interpolation mode, if the value keeps changing, it means that there is communication interference or the synchronization period is inconsistent with the master station setting	/

- CAN communication interruption alarm function



For the communication interruption alarm function, the following parameters need to be set

Table 9 - 29 Communication interrupt alarm function setting

CANopen address	Name	Meaning	Default value
100C0010	Node protection time	Through node protection, the master station can monitor the current status of each node. The master station sends a remote frame (the default COBID is 0x700+ station number and contains no message) to query the status of the slave node according to the node protection period. The slave node needs to respond within a certain time range, otherwise the master node considers the slave node offline and the driver enters the alarm state.	1000
100D0008	Node protection time coefficient		3
100E0020	Node protection ID	700+ drive ID	
10140020	Emergency message station number	80+ drive station number	
60070010	Communication interrupt mode	CAN communication interruption mode: determines the action logic that the driver still does not receive the node protection packet after the node protection time x node protection coefficient is exceeded 0: No processing 1: An error is reported	0

Chapter 10 Alarm exclusion

10.1 Mistakes and historical errors

Error: Click "Driver" -> "Error Display", or click the  button (becomes  when an error occurs), the error window will pop up and display the most recent error message. Troubleshoot the fault according to Chapter 10, section 10.2.

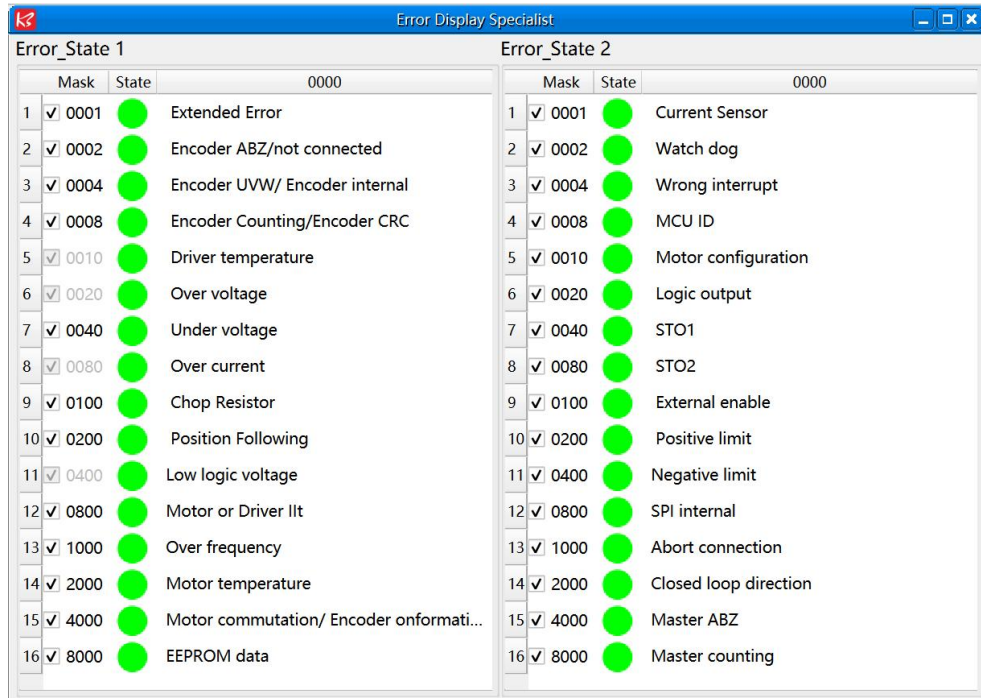


Figure 10-1 Error display interface

Historical error: Click the menu bar "Driver" -> "Error History", the error history window will pop up, and display the latest 8 error information, including error word, bus voltage, speed, current, temperature, working mode, power tube status. The most recent historical fault is displayed on the first line.

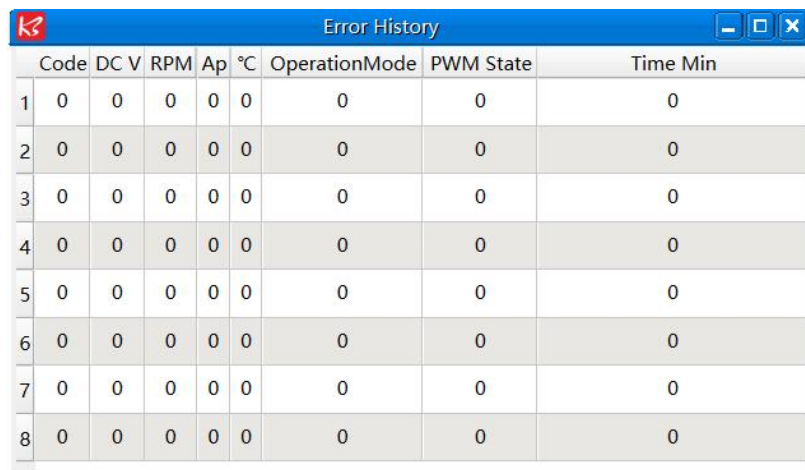


Figure 10-2 History error display screen

Table 10-1 Error status (2601.00) information

Bit	Error Name	Error code	Description
0	Extended error		Refer to Error Status 2 definition (2602.00)
1	Encoder communication error	0x7331	Communication encoder not connected
2	Encoder internal fault	0x7320	Encoder internal fault
3	Encoder CRC error	0x7330	Encoder communication is being interfered with
4	Driver temperature	0x4210	Heat sink temperature is too high
5	Overvoltage	0x3210	Bus overvoltage
6	Undervoltage	0x3220	Bus undervoltage
7	Overcurrent	0x2320	Driver power tube or motor short circuit
8	Chop resistor	0x7110	Brake resistance overload
9	Following error	0x8611	The actual following error exceeds the maximum set following error
10	Low logic voltage	0x5112	The logical power supply voltage is too low.
11	Motor or driver Ilt	0x2350	The motor or drive power tube Ilt is faulty
12	Overfrequency	0x8A80	The pulse input frequency is too high
13	Motor temperature	0x4310	Motor temperature sensor alarm
14	Encoder information error	0x7331	Encoder is not connected or encoder communication times out
15	EEPROM data error	0x6310	EEPROM data verification error

Table 10-2 Error status 2 (2602.00) information

Bit	Error Name	Error code	Description
0	Current sensor	0x5210	Current sensor signal offset or ripple too large
1	Watchdog	0x6010	Software watchdog exception
2	Wrong interrupt	0x6011	Invalid interrupt exception
3	MCU ID	0x7400	Wrong MCU type detected
4	Motor configuration	0x6320	No motor data in EEPROM / motor never configured
5~7	Reserved		
8	External enable	0x5443	DIN "pre-enable" function is configured, but the DIN is inactive when the controller is enabled / going to be enabled
9	Positive limit	0x5442	Positive position limit (after homing) – position limit only causes error when Limit_Function (2010.19) is set to 0.
10	Negative limit	0x5441	Negative position limit (after homing) position limit only causes error when Limit_Function(2010.19) is set to 0.
11	SPI internal	0x6012	Internal firmware error in SPI handling
12	CAN abort connection	0x8100	The fault alarm will be generated only when the communication interruption mode (6007.00) is set to 1
13	Closed loop direction	0x8A81	In the full closed-loop working state, the counting direction of the main encoder is opposite to that of the motor encoder
14	Master ABZ	0x7382	Master encoder connection error
15	Master counting	0x7306	The main encoder index signal is abnormal



Remind

There's a mask checkbox beside every error item, all are defaulted to be checked, means it can be unchecked, means it can't be unchecked. An unchecked means the related error will be ignored. The error mask can also be set with the object error mask (2605.01) and error mask 2 (2605.04) (see table 10-4).

Table 10-3 Error extension (2605.07) information

Bit	Error Name	Error code	Description
0	Origin record error	0x5210	Current sensor signal drift or ripple is too large
1	Internal braking resistor overtemperature	0x7111	The actual power of the internal braking resistor is too high
2	Internal braking resistor short circuit	0x7112	Internal braking unit damaged, braking circuit short circuit
3	Motor phase loss	0x6321	A phase in the motor power line UVW is not connected
4	ADC sampling saturation	0x2321	Current sampling ADC reaches limit, current runaway
12	service timeout	0x81FF	Communication Bus Error Extension

Table10-4 Error mask

Internal address	Type	Name	Description	Default
2605.01	Uint16	Error_Mask	Mask of Error_State(2601.00). Bit = 0 means related error will be ignored.	0xFFFF
2605.02	Uint16	Store_Mask_ON	Error mask for Error_History of Error_State(2601.00) when controller is enabled. Bit = 0 means related error won't be stored in the Error_History	0xFBFF
2605.03	Uint16	Store_Mask_OFF	Error mask for Error_History of Error_State(2601.00) when controller is not enabled. Bit = 0 means related error won't be stored in the Error_History	0x0000
2605.04	Uint16	Error_Mask2	Mask of Error_State2(2602.00). bit = 0 means related error will be ignored	0xFFFF
2605.05	Uint16	Store_Mask_ON2	Error mask for Error_History of Error_State2(2602.00) when controller is enabled. Bit = 0 means related error won't be stored in the Error_History	0xF1FF
2605.06	Uint16	Store_Mask_OFF2	Error mask for Error_History of Error_State2(2602.00) when controller is not enabled. Bit = 0 means related error won't be stored in the Error_History	0x003F

10.2 Alarm cause and treatment measures

When the drive alarms, the red ERR light of the drive will be steady on.

If you want to query more detailed error information and error history, please use the RS485 serial port communication cable (or usb debugging cable) to connect the drive to the upper computer to view.

Table 10 - 5 Error status word 1 alarm code

Alarm code	Alarm information	Reason	Troubleshooting
FFF.F	The motor is not configured or the motor is incorrectly configured	1. The driver is not equipped with a motor. 2. The current motor model is different from the motor model saved by the driver	1. the driver factory parameters do not include motor configuration, connect the motor encoder line can automatically identify the motor parameters. 2. Connect the upper computer software to check whether the current motor model matches the motor code on the nameplate; When the current motor model is different from the actual connected motor, please re-identify the motor parameters.
000.1	Extended Error	Error status word 2 alarm	Look at the error status word 2 and check the meaning of the error against the alarm code.
000.2	Encoder communication failure	Encoder cable error or not connected; The presence of a 400.0 alarm indicates that the communication encoder is not responding	Step 1: Make sure that the encoder between the driver and the motor is properly connected and the cable is firmly connected. Step 2: Check whether the current motor model matches the motor code in the nameplate through the upper computer software. If the current motor model is different from the actual motor, please refer to 4.2 Chapter to self-identify the motor parameters.

000.4	Encoder internal fault	Multi-turn absolute encoder multi-turn data is invalid, need to reset	Step 1: Use the host software to modify the communication encoder data reset (0x269000) to 10. Step 2: Reset the faulty or restart the drive. If the error persists, check whether the battery cable is securely connected, and try to replace the battery cable or compare the motor.
000.8	Encoder CRC error	Motor model setting error; Encoder wiring error or external interference caused;	1, Whether the motor configuration is correct Step 1: Check whether the current motor code is consistent with the motor code in the connected motor nameplate through the upper computer software. Step 2: Make sure that the encoder between the driver and the motor is properly connected and the cable is firmly connected. 2, check whether the driver grounding wire is well connected (different from the motor PE wire) 3. Check whether the grounding cable of the entire device is well connected. 4. Use an independent power supply to power the drive.
001.0	Driver overtemperature	The temperature of the drive power module reaches the alarm value	Step 1: Check whether the motor and drive power meet the requirements. Step 2: Restart the drive and check whether the cooling fan can be started during the power-on process. Check that the heat dissipation hole in the driver housing is blocked. Step 3: When the ambient temperature exceeds 40°, take heat dissipation measures or derate the power cabinet. Step 4: Increase the drive installation distance appropriately Step 5: The internal power circuit of the driver is damaged. Replace the driver.
002.0	Overvoltage	The DC bus voltage exceeds the overvoltage alarm point	Step 1: Check whether the power supply voltage is within the driver input voltage range and whether the power supply voltage is stable. Step 2: The energy generated in high-speed braking occasions will be fed back to the driver bus capacitor, and it can be considered to connect a suitable brake resistance to absorb and consume excess energy through the brake resistance. Step 3: If the brake resistance value is too large, the bus energy leakage is not timely, and the brake resistance value should be reduced. Note: iSMK series does not support external brake resistors, FD1X5 series brake resistors recommended range please see section 3.2.2.1
004.0	Undervoltage	The DC bus voltage is lower than the low voltage alarm point	Step 1: Check whether the power supply voltage is within the driver input voltage range and whether the power supply voltage is stable. Step 2: Power on the power supply and then the logic power supply, and ensure that the drive is connected to the power supply before enabling the power supply.
008.0	Overcurrent	Instantaneous current exceeds the overcurrent protection value.	Step 1: Check whether the motor configuration parameters are consistent with the motor drawing. Step 2: Check whether there is a short circuit between the power line UVW, and try to replace the power cable/motor/driver for comparison. Step 3: Interference causes an overcurrent alarm. For details, see 3.4 Setting EMC Conditions.
010.0	Chop Resistor	External brake resistance is overloaded	Step 1: Check whether the external brake resistance value and brake resistance power are set correctly on the upper computer. Step 2: The brake resistor power is insufficient, replace the brake resistor with a higher power.
		Internal brake resistance overtemperature	The power of the brake resistance inside the driver is insufficient. Please disconnect the short cable between DC+/RB1 and RB-end, and connect the appropriate external brake resistance between DC+/RB1 and RB-end.
		Internal brake unit damaged, brake circuit short circuit	After the driver is powered off, use a multimeter to measure the DC- and RB-ends. If the driver works properly, replace the driver.

020.0	Following Error	The actual following error exceeds the set maximum following error value. The possible reasons are: 1. The motor cable is improperly connected 2. The control ring is too rigid 3. The maximum following error is set too small 4. Target speed exceeds maximum speed limit 5. The target torque limit is too small 6. The lock is not opened 7. Mechanical plug/friction	Step 1: Make sure the power cable UVW is connected correctly Step 2: Readjust the gain and increase the rigidity. Refer to Chapter 5 for the rigidity adjustment method Step 3: Readjust the maximum follow error (0x606500) Step 4: Readjust the maximum speed limit (0x607f00) Step 5: Readjust the target current limit (0x607300), the default value of the target current limit is equal to the maximum motor current (0x64100B) Step 6: Measure whether the lock line connection is normal, measure the lock voltage, replace the motor and compare the test Step 7: Remove mechanical jams and apply lubricant
040.0	Low logic voltage	The logic voltage is lower than the lower alarm limit	Check whether the logic voltage is within the driver input voltage range and the power supply voltage is stable
080.0	Motor or drive IIT error	The motor or drive is overloaded for a long time, the possible reasons are: 1. Motor power line and encoder wiring error 2. When the motor shaft is rotating, the lock is not loosened 3. The drive control ring parameters are incorrectly set 4. The mechanical device is stuck or the friction is too large 5. Driver/motor selection error can not meet the application requirements	Step 1: Check that the encoder/power line is properly connected Step 2: Measure whether the brake line connection is normal, measure the lock voltage, replace the motor and compare the test Step 3: Adjust the parameters of the control ring Step 4: Eliminate mechanical jams and apply lubricant Step 5: Run with reduced load or replace with more powerful products
100.0	Over frequency	External input pulse frequency is too high	1 reduce the pulse frequency 2, when using more than 600KHz pulse, need to increase the pulse frequency control 0x250808 value.
200.0	Motor temperature	The motor temperature exceeds the specified value.	User-defined alarm
400.0	Encoder information error	Encoder cable error or not connected; The presence of a 000.2 alarm indicates that the communication encoder is not responding	Step 1: Make sure that the encoder between the driver and the motor is properly connected and the cable is firmly connected. Step 2: Check whether the current motor model matches the motor code in the nameplate through the upper computer software. If the current motor model is different from the actual connected motor, please set the correct motor parameters.
800.0	EEPROM error	Data is damaged when the power is turned on and data is read from the EEPROM.	Step 1: After initializing the control ring parameters, save the control parameters and restart the drive Step 2: Import the cdi file through the host software

Table 10-6 Error status word 2 Alarm code

Alarm code	Alarm information	Reason	Troubleshooting
000.1	Current sensor	Current sensor signal offset or ripple too big	Step 1: The current sensor generates an alarm due to external interference. For details, see 3.4 Setting EMC Conditions. Step 2: Current sensor circuit is damaged, replace the driver and compare.
000.2	Watchdog	Software watchdog exception	After initializing the control ring parameters, save the control parameters and restart the drive.
000.4	Wrong interrupt	Invalid interrupt exception	After initializing the control ring parameters, save the control parameters and restart the drive.
000.8	MCU fault	1. The software program does not match the hardware 2. An MCU error is detected	Step 1: Check the software version in the drive properties and update the correct software Step 2: Replace the drive and compare.
001.0	Motor misconfiguration	1. Motor model cannot be automatically identified EEPROM has no motor data or the motor is not configured correctly 2. The motor line is missing, and a phase of the power line UVW is not connected	Step 1: Connect the host computer software to check whether the current motor model matches the motor code on the nameplate; If the current motor model is different from the actual connected motor, reset the correct motor parameters. Step 2: Make sure the motor power line UVW is connected correctly and reliably Step 3: Replace the power cable or driver comparison test.
010.0	External enable	DIN function "pre_enable" is configured, but the input is inactive when the controller is enabled or should become enabled	User-defined alarm

020.0	Positive limit	Positive position limit (after homing), position limit only causes error when Limit_Function (0x201019) is set to 0.	User-defined alarm
040.0	Negative limit	Negative position limit (after homing), position limit only causes error when Limit_Function (0x201019) is set to 0.	User-defined alarm
080.0	SPI fault	Internal firmware error in SPI handling	Please contact the supplier.
100.0	CAN bus fault	This function is enabled only when the Communication interruption mode (0x600700) is set to 1	User-defined alarm
200.0	Closed loop direction	In full closed loop mode, the counting direction of the main encoder is opposite to that of the motor encoder	Step 1: Check the count direction of the main encoder and the count direction of the motor encoder, the count direction is inconsistent, please change the count direction of the main encoder (0x250A03) Step 2: The master encoder speed is not proportional to the motor encoder speed. Check the mechanical installation, exclude mechanical slippage or jammed, check the full closed spindle check (0x250A05) and full closed slave shaft check (0x250A06) and full closed loop ratio check (0x250A09) Settings.
400.0	The main encoder ABZ fault	Master encoder connection error	Check that the main encoder signal line is connected correctly
800.0	Master counting error	Master encoder index signal is abnormal	Step 1: Correctly fill in the main encoder period (0x250A01) and set it to 0 to disable check. Step 2: Check for interference

Table 10-7 Performance anomalies and solutions

Anomalies	Alarm reason	Solutions
Motor no load operation abnormal sound or vibration	<ol style="list-style-type: none"> 1. Wiring error 2. Improper setting of control loop parameters 3. Improper installation of motor oil seal or motor failure 	<p>Use standard power cables, encoder cables, and control cables to ensure that the cables are properly connected and are not loose or damaged. Initialize Control parameters - The storage control parameters restart before trying to run.</p> <p>Hand twist the motor bearing to check whether the motor is abnormal and try to reinstall the motor oil seal.</p>
Incorrect positioning	<ol style="list-style-type: none"> 1. Improper control loop parameters 2. The pulse data in front of the gear is inconsistent with the number of pulses delivered by the controller 3. The electronic gear ratio is set too large 4. Cumulative error of reciprocating motion 5. Mechanical system factors 	<p>Adjust drive control ring parameters according to Section 5</p> <p>Use shielded twisted pair cables for pulse cables. If the cables are long, increase the diameter of the control cables appropriately. The pulse line is as far away from the power cord as possible, and the driver is well grounded to the motor.</p> <p>Resume factory gear ratio operation.</p> <p>The machine is returned to the original where the process permits, and the origin is searched before the accumulated error exceeds the allowable. Check whether the coupling equipment is firmly installed, the pulley or gear is well fastened, the load inertia is too large, and try to reduce the load or replace a more powerful motor.</p>

Appendix I Method of configuring a third-party motor

Name	Parameter	Note
Number of motor poles	Must be filled in	Please refer to the motor drawing
Maximum motor current	Must be filled in	Please refer to the motor drawing
Phase inductance	Must be filled in	The parameter on the motor drawing $\times 100$ gets configuration parameters
Phase resistance	Must be filled in	The parameter on the motor drawing $\times 100$ gets configuration parameters
Reverse electromotive force	Must be filled in	Please refer to the motor drawing
Torque coefficient	Must be filled in	Please refer to the motor drawing
Rotor inertia	Must be filled in	Please refer to the motor drawing
Brake duty cycle	Reference remarks	90%
Brake delay	Reference remarks	150ms
Motor model	Reference remarks	The FD1x5 driver currently supports only the Tonomagawa encoder protocol, with the following Settings: Tama River: VX
Use the internal motor library	Reference remarks	Set it to either 1 or 2
Feedback type	Reference remarks	Set the corresponding value according to the encoder feedback type. Bit0: UVW cable check Bit2: Communication type wiring check Bit4: ABZ connection check Bit5: Provincial encoder Tonomagawa encoder set to: 04
Feedback accuracy	Reference remarks	Encoder feedback accuracy Incremental: Number of encoder lines $\times 4$ Communication type: the resolution of a single turn is less than 16 bits set to the actual encoder resolution; Single-turn resolution higher than 16 bits is generally set to 65536 to prevent position overflow
Feedback cycle	Reference remarks	Incremental: The number of pulses per turn of the motor Communication type: Define the encoder type, for example, multi-turn 16-bit, single-turn 17-bit, and feedback period set to 0x1617 for the Tama Agawa encoder
Excitation mode	Reference remarks	Mode 0 or mode 10
Excitation current	Reference remarks	Smaller than the rated current, generally 0.75 times the rated current of the motor
Excitation time	Reference remarks	The default value is 2000ms
Motor iit current	Reference remarks	Generally set to rated current
Motor iit time	Reference remarks	Usually 60 s
Motor current loop bandwidth	Reference remarks	The default value is 2000Hz



Note

- After filling in the above forms, enter our upper computer software, find the motor configuration and selection, fill in the information in turn, and finally save the motor parameters, initialize the control ring parameters, and restart the drive.
- Power on and find that the motor does not have any alarm, you can start to try to run other control modes.
- If there is an alarm, check the corresponding drive manual step by step.
- Before trial operation of the motor, limit the target current to prevent excessive output current of the driver.
- If it is found that the motor does not have any alarm and the motor does not turn, first check whether the resolution is set correctly, then check whether the UVW line is connected inversely, sometimes due to the different specifications of various manufacturers, it may be necessary to adjust the UV line, and finally check whether the excitation mode is set correctly.
- The two parameters of phase inductance and phase resistance need to be multiplied by 100 to get the correct configuration value.

Appendix II Commonly used formulas

The selection method of the trolley motor is suitable for the mechanism of the motor + reducer + wheel

Formula: $T \cdot n = \mu \cdot m \cdot g \cdot d / 2$	
Diameter of wheel d	m
The reduction ratio of the reducer n	1: n
Torque of motor T	Nm, kgm^2/s^2
Full load capacity m	kg
friction coefficient μ	unitless
gravitational acceleration g	m/s^2

The relationship between the number of pulses and mechanical displacement in pulse mode

Formula: $N \cdot A / B = s \cdot n \cdot r / P$	
Gear ratio molecule A	unitless
Gear score B	unitless
Ball screw lead P	mm
The number of pulses per turn of the motor r	unitless
Reduction ratio $1: n$	unitless
Mechanical displacement s	mm
Pulse count N	unitless

The relationship between speed and linear velocity

Formula: $n = v \div r \div \pi$	
Speed n	rpm
linear velocity v	mm/s
Radius r	mm

Parameter Name	Engineering unit	Internal unit	Conversion relation
Speed	rpm	DEC	$\text{DEC} = \lceil (\text{RPM} \cdot 512 \cdot \text{encoder resolution}) / 1875 \rceil$
Acceleration		DEC	$\text{DEC} = \lceil (\text{RPS}/\text{S} \cdot 65536 \cdot \text{encoder resolution}) / 4000000 \rceil$
Current	A	DEC	$1\text{Arms} = \lceil 2048 / (\text{drive peak current } I_{\text{peak}} / 1.414) \rceil \text{dec}$

For example:

The speed engineering unit is rpm, the internal unit is dec, and the relationship between the two is that 1RPM is equal to 2730dec (encoder resolution 10000)! Assuming that the required speed is 10rpm, then the write speed is 27300dec when using the communication control and 6AA4 in hexadecimal.

The current engineering unit is Arms, the internal unit is dec, assuming that the driver used is FD125 (driver peak current I_{peak} is 48A), then 1Arms is equal to about 60dec, if the current needs to be 10Arms, then the current needs to be written to 600d when using communication control.